

Appendix N

Black Hills Supporting Documents

Table of Contents

<u>Black Hills Energy OATT Attachment K.....</u>	<u>2</u>
<u>Black Hills Energy OATT Attachment K Business Practice</u>	<u>82</u>
<u>Black Hills Energy Transmission System Planning Methodology, Criteria and Process Business Practice</u>	<u>115</u>
<u>Black Hills Energy Available Transfer Capability Implementation Document (ATCID).....</u>	<u>133</u>
<u>Black Hills Energy Transmission Reliability Margin Implementation Document (TRMID).....</u>	<u>141</u>
<u>Black Hills Energy Capacity Benefit Margin Implementation Document (CBMID).....</u>	<u>145</u>
<u>Black Hills Energy Economic Planning Study Request Form</u>	<u>152</u>
<u>Black Hills Energy Facility Rating Methodology</u>	<u>154</u>
<u>Black Hills Energy 2016 ERP Load Forecast Attachment LS-1, Section 4</u>	<u>173</u>
<u>Black Hills Energy 2015 Senate Bill 07-100 Report</u>	<u>189</u>
<u>Black Hills Energy 2017 Senate Bill 07-100 Report</u>	<u>207</u>
<u>Black Hills Energy 2019 Senate Bill 07-100 Report</u>	<u>221</u>
<u>Black Hills Energy 2021 Senate Bill 07-100 Report</u>	<u>239</u>
<u>Black Hills Colorado Electric Generator Interconnection Queue</u>	<u>260</u>

Black Hills Energy OATT Attachment K



ATTACHMENT K

Transmission Planning Process

Index

- I. Overview of the Black Hills Colorado Electric, LLC Transmission Planning Process.....1
 - A. Definitions.....2
- II. Local Planning Process3
 - A. Confidential or Proprietary Information3
 - B. Types of Planning Studies3
 - C. Preparation of a LTP4
 - D. Coordination5
 - E. Information Exchange.....8
 - F. Transparency.....11
 - G. Cost Allocation12
 - H. Economic Planning Studies14
 - I. Dispute Resolution.....17
 - J. Transmission Business Practices18
 - K. Planning for Public Policy Requirements in the Local Planning Process18
- III. Regional Planning Process.....20
 - A. Overview.....20
 - B. Roles in the Regional Transmission Planning Process24
 - C. Submission of Data by Customers, Transmission Developers, and Transmission Owners.....28
 - D. Transmission Developer Qualification Criteria34
 - E. Regional Planning Methodology and Protocols; Evaluation and Selection of Solution Alternatives40
- IV. Recovery of Planning Costs:.....52
- V. Dispute Resolution:.....53
- VI. Coordination at the Western Interconnection Level54
 - A. Procedures Regional Planning Project Review.....54
- VII. Cost Allocation and New Projects55
 - A. Local Transmission Projects55
 - B. Regional Transmission Projects.....57
- VIII. Interregional Planning.....73
 - A. Definitions.....74
 - B. Annual Interregional Information Exchange75
 - C. Annual Interregional Coordination Meeting.....76
 - D. ITP Joint Evaluation Process76
 - E. Interregional Cost Allocation Process77
 - F. Application of Regional Cost Allocation Methodology to Selected ITP79
- Exhibit 180

Attachment K

Transmission Planning Process

I. Overview of the Black Hills Colorado Electric, LLC Transmission Planning Process

Black Hills Colorado Electric, LLC (“Black Hills”), is a vertically integrated public utility engaged in the business of generating, transmitting and distributing electricity in south central Colorado.

Black Hills’ transmission planning process is intended to facilitate the development of electric infrastructure that maintains reliability, responds to service requests and meets load growth, and is based on the following objectives:

- Maintain reliable electric service.
- Improve the efficiency of electric system operations, including the provision of open and non-discriminatory access to its transmission facilities.
- Identify and promote new investments in transmission infrastructure in a coordinated, open, transparent and participatory manner.

The transmission planning process conducted by Black Hills includes a series of open planning meetings that allows interested parties, including, but not limited to, NITS and PTP customers, sponsors of transmission solutions, generation solutions and solutions utilizing demand response resources, interconnected transmission providers, state and local regulatory bodies and other stakeholders (jointly, “Stakeholders”), input into and participation in all stages of development of the transmission plan.

In addition to its local transmission planning process, Black Hills coordinates its transmission planning with other transmission providers and Stakeholders in the Rocky Mountain region, and the Western Interconnection as a whole, through its active participation in the Colorado Coordinated Planning Group (“CCPG”), membership in WestConnect,¹ membership in the

Western Electricity Coordinating Council (“WECC”), and participation in the WECC Transmission Expansion Planning Policy Committee (“TEPPC”) and its Technical Advisory Subcommittee (“TAS”).

¹ WestConnect was formed under a memorandum of understanding (MOU) voluntarily entered into by FERC jurisdictional and non-jurisdictional transmission providing electric utilities in the Western Interconnection. The purposes of WestConnect are to investigate the feasibility of wholesale market enhancements, work cooperatively with other Western Interconnection organizations and market shareholders and address seams issues in the appropriate forums. WestConnect has initiated an effort to facilitate and coordinate regional transmission planning across the WestConnect footprint. Following the effective date of Transmission Provider’s September 20, 2013 Order No. 1000 compliance filing, the WestConnect Order No. 1000 regional transmission planning management committee will commence the regional transmission planning process under the principles set forth in FERC’s order *Preventing Undue Discrimination and Preference in Transmission Service*, Order No. 890, FERC Stats. & Regs. ¶ 31,241 (2007), et al. (collectively, “Order No. 890”), and carried forward in FERC’s order *Transmission Planning and Cost Allocation by Transmission Owning and Operating Utilities*, Order No. 1000, 136 FERC ¶ 61,051 (2011), et al. (collectively, “Order No. 1000”).

Three subregional planning groups operate within the WestConnect footprint: CCPG, the Southwest Area Transmission (“SWAT”) group, and the Sierra Coordinated Planning Group (“Sierra”). WestConnect’s planning effort, which includes funding and provision of planning management, analysis, report writing and communication services, supports and manages the coordination of the subregional planning groups and their respective studies. Such responsibilities are detailed in the WestConnect Project Agreement for Subregional Transmission Planning (“WestConnect STP Agreement”), dated May 23, 2007. (See Black Hills’ Attachment K Hyperlinks List posted on its OASIS <http://www.oatioasis.com/bhct/>, and other project agreements that may be entered into from time to time.

Black Hills is a signatory to the WestConnect STP Agreement.

The subregional planning groups within the WestConnect footprint, assisted by the WestConnect planning manager (pursuant to the WestConnect STP Project Agreement) formed the WestConnect Planning Management Committee to comply with the requirements of Order No. 890 and Order No. 1000 and coordinate with other Western Interconnection transmission providers and their regional and subregional planning groups through TEPPC. TEPPC provides for the development and maintenance of an economic transmission study database for the entire Western Interconnection and performs annual congestion studies at the Western Interconnection regional level. Black Hills’ participation in interregional planning in the United States portion of the Western Interconnection in compliance with Order No. 1000 is set out in Part VIII of this Attachment K.

A. Definitions

1. LTP: Local Transmission Plan is the transmission plan of Black Hills that identifies the upgrades and other investments to the Transmission System or demand response necessary to reliably satisfy, over the planning horizon, Network Customers’ resource and load growth expectations for designated Network Load; Black Hills’ resource and load growth expectations for Native Load Customers; Black Hills’ obligations pursuant to grandfathered, non-OATT agreements; and the Black Hills’ Point-to-Point customers’ projected service needs including obligations for rollover rights.
2. CCPG: Will mean Colorado Coordinated Planning Group or its successor organization.
3. WestConnect: Will mean the WestConnect Regional Transmission group or its successor organization.
4. Stakeholder Meeting: Meetings periodically held by Black Hills for the Purpose of soliciting input from Stakeholders on Black Hills’ LTP.
5. Stakeholder: Will include, but is not limited to, network and point-to-point transmission customers, sponsors of transmission solutions, generating solutions and solutions utilizing demand response resources, interconnected neighbors, regulatory and state bodies and other parties.
6. TEPPC: Will mean Transmission Expansion Policy and Planning Committee or its successor committee with WECC.

7. TCPC: Will mean Black Hills' Transmission Coordination and Planning Committee which is a stand-alone advisory committee comprised of eligible Stakeholders who will provide input to Black Hills' LTP.
8. WECC: Will mean Western Electricity Coordinating Council or its successor organization.

II. Local Planning Process

A. Confidential or Proprietary Information

Black Hills' local transmission planning studies may include base case data that are WECC proprietary data or classified as Critical Energy Infrastructure Information ("CEII") by the Federal Energy Regulatory Commission ("FERC"). A stakeholder must hold membership in or execute a non-disclosure agreement with WECC (see Black Hills' Attachment K List of Hyperlinks <http://www.oatioasis.com/bhct/> in order to obtain requested base case data from WECC. A stakeholder may obtain Black Hills transmission planning information classified as CEII information from Black Hills upon execution of a non-disclosure agreement with Black Hills, as applicable.

B. Types of Planning Studies

1. Transmission Planning Studies. Black Hills will conduct local reliability studies to ensure that all North American Electric Reliability Corporation ("NERC"), WECC, and local reliability standards are met for each year of the ten-year planning horizon, including all Black Hills customer's requirements for planned loads and resources, including NTAs. These reliability studies will be coordinated with the other regional transmission planning organizations through CCPG studies.
2. Economic Studies. Economic planning studies are performed to identify significant and recurring congestion on the transmission system and the effects of load growth, load management programs and adding new resources. Such studies may analyze any, or all, of the following: (i) the location and magnitude of the congestion, (ii) possible remedies for the elimination of the congestion, in whole or in part, including transmission solutions, generation solutions, and solutions utilizing NTAs, (iii) the associated costs of congestion, (iv) the cost associated with relieving congestion through system enhancements (or other means), and as appropriate (v) the economic impacts of load growth, load management programs and adding new resources. Black Hills will perform, or cause to be performed, economic planning studies at the request of any transmission customer or stakeholder. All economic planning studies performed, either Black Hills or TEPPC, will utilize the TEPPC public data base or other appropriate public data.
3. Consideration of Public Policy Requirements. For purposes of this

Attachment K, “Public Policy Requirements” means those requirements enacted by state or federal laws or regulations, including those enacted by local governmental entities, such as a municipality or county. Public Policy Requirements, as applicable, are incorporated into the load forecasts and/or are modeled in the local planning studies. Proposed public policy (public policy proposed before a governmental authority but not yet enacted) may be studied if time and resources permit.

C. Preparation of a LTP

1. Black Hills will prepare, with the input of interested Stakeholders, one LTP every year. The preparation of the LTP will be done in accordance with the general policies, procedures, and principles set forth in this Attachment K.
2. Black Hills will establish a process by which Stakeholders can discuss, question, or propose alternatives for input assumptions and upgrades identified by Black Hills. Black Hills will consider information obtained from Stakeholders for future planning cycles. Black Hills may, following Stakeholder input, also include results of completed Economic Studies.
3. Black Hills will use a ten (10) year or other applicable planning horizon for the LTP. The transmission planning process will use reliability criteria established by Black Hills, WECC, NERC and FERC.
4. The LTP on its own does not effectuate any transmission service requests. Transmission Service Requests must be made in accordance with the procedures set forth in Part II of the OATT and posted on Black Hills’ OASIS. Similarly, Network Customers must submit Network Resource and load additions or removals pursuant to the process described in Part III of the OATT.
5. Black Hills will take the LTP into consideration, as appropriate when preparing generation interconnect, transmission service and economic studies. Black Hills will take the generation interconnect, transmission service and economic study results into consideration as appropriate when preparing the LTP.
6. Black Hills will prepare and develop the LTP using an open and coordinated process that includes input from Stakeholders as defined in Section II.D.3. Stakeholder input will occur at various phases throughout the study process consistent with the principles, practices, policy and procedures set forth in this Attachment K. Black Hills, with interested Stakeholder input, will: (1) determine the Study Plan, define scenarios and develop base cases related to the LTP; (2) perform the Technical Study; (3) determine the preliminary LTP, based on the data produced during the Technical Study and if applicable, include timely submitted Economic Study Request results; and (4) report study results and the LTP to Stakeholders and Affected Parties.

7. Limitations on Disclosure: While Black Hills' LTP planning process will be conducted in the most open manner possible, Black Hills has an obligation to protect sensitive information such as, but not limited to, Critical Energy Infrastructure Information (CEII) and the proprietary materials of third parties. Nothing in this Attachment K will be construed as compelling Black Hills to disclose materials in contravention of any applicable regulation, contractual arrangement, or lawful order unless otherwise ordered by a governmental agency of competent jurisdiction. Black Hills may employ mechanisms such as confidentiality agreements, protective orders, or waivers to facilitate the exchange of sensitive information where appropriate and available.
8. Black Hills will adhere to all applicable laws and regulations in preparing the LTP, including but not limited to CEII. Any Stakeholder of Black Hills participating in the planning process must adhere to the Commission's guidelines concerning CEII as set out in the Commission's regulations, Order Nos. 683 and 683-A (or and successor thereto). Additional information concerning CEII, including a summary list of data that is determined by the supplying party to be deemed CEII, will be posted on Black Hills' OASIS.

D. Coordination

1. LTP Study Cycle: Black Hills will prepare an LTP during a four (4) quarter study cycle.
2. LTP Sequence of Events: Black Hills will use the following timeline in preparing its LTP.
 - a. Quarter 1: Data Collection, Study Scope and Scenario Development
 - (i) Black Hills will gather: (1) Network Customers' projected loads and resources, and load growth expectations (based on annual updates under Part III of the OATT); (2) Black Hills' projected loads and resource needs for its Native Load Customers; (3) Point-to-Point Customer's projections for long-term (greater than 1 year) needs at each receipt and delivery point (based on information submitted by Eligible Customers to Black Hills) including projections of rollover rights; (4) information from all Transmission Customers and Black Hills on behalf of Native Load Customers concerning existing and planned demand resources and their impact on demand and peak demand and (5) information from sponsors of transmission solutions, generating solutions and solutions utilizing demand response resources. Black Hills will take into consideration, to the extent known or which may be obtained from its Transmission Customers and Stakeholders,

obligations that will either commence or terminate during the applicable study window. Customer Economic Study Requests will also be submitted to Black Hills during this quarter. Black Hills will, with Stakeholder input, define the proposed LTP study scope, objectives, scenarios to be considered in development of the LTP. Black Hills will post the official timelines for data submittals on its OASIS.

- (a) Black Hills will have a TCPC meeting during the first quarter to accept Stakeholder input to the LTP. Black Hills will, with Stakeholder input, finalize and post on the OASIS the basic methodology, planning criteria, assumptions and processes Black Hills will use to prepare the LTP. As part of the TCPC meeting, Black Hills will finalize study objectives, scenarios to be studied, discuss data collected, adequacy of the data, the need for any additional data and discuss applicable Economic Study Requests.

b. Quarter 2-3: Technical Study

- (i) Black Hills will develop base cases that include load and resource data to represent the defined scenarios.
- (ii) Black Hills will conduct a combination of powerflow, transient stability studies, post transient power flow or other studies deemed necessary to properly analyze the transmission system.
- (iii) Black Hills will consider transmission and non-transmission solutions to mitigate system performance that does not meet reliability criteria. Black Hills may consider the results from prior applicable Economic Studies.
- (iv) Black Hills may elect to post interim iterations of the draft plan or preliminary technical study results, and solicit comments prior to the end of the applicable quarter. Black Hills will seek interested Stakeholder input regarding advantages and disadvantages associated with proposed solutions in the transmission plan or technical study.

c. Quarter 4: Decision and Reporting

- (i) Black Hills will solicit Stakeholder input when determining selection criteria and weighting to be used in determining the best transmission or non-transmission solution identified in the draft LTP. Advantages and disadvantages to each solution will also be considered.

- (ii) Selection criteria may include, but are not limited to, the following:
 - (a) Total present value of upgrade costs
 - (b) Time available to implement upgrade
 - (c) System performance with each solution
 - (d) Probability of scenario requiring a solution
 - (e) Environmental assessment and/or costs
 - (f) Non-quantifiable assessment
 - (iii) Black Hills will prepare and publish a draft LTP report on its OASIS and solicit input from all Stakeholders.
 - (iv) Using data and information from the Technical Study, and considering Stakeholder input, Black Hills will define its ten (10) year LTP.
 - (v) The final LTP report will be posted on Black Hills' OASIS and provided to applicable sub-regional and regional entities conducting similar planning efforts, interested Stakeholders, and the owners and operators of the neighboring interconnected transmission systems.
 - (vi) The responsibility for the LTP will remain with Black Hills who may accept or reject in whole or in part, the comments of any Stakeholder unless prohibited by applicable law or regulation.
3. Stakeholder Meetings: Black Hills will establish the TCPC to be used as the forum for Stakeholder input throughout the study cycle described in Section II.D.1. TCPC membership and meetings will be open to all Stakeholders, including but not limited to Eligible Customers, other transmission providers and federal and state commissions. Black Hills will utilize quarterly scheduled TCPC meetings to solicit, obtain, and coordinate the input of interested Stakeholders throughout the Local Planning Process. Notice of TCPC meetings will be posted on Black Hills' OASIS with ten (10) business day's prior notice. A list of participants or members will be maintained and will receive email notifications for upcoming meetings. The location of the meeting will be selected by Black Hills. Black Hills will provide for alternate means of participation, to the extent practical and economical, such as teleconference, web conference or other similar means. Instructions for participation in TCPC meetings will be posted and maintained on Black Hills' OASIS. The TCPC Charter is further described

in Attachment K Business Practices posted on Black Hills' OASIS website.

4. Stakeholder Comments: In addition to Stakeholder input noted in Section II.D.3 above, at each TCPC meeting, Black Hills will: (1) discuss the status of the local transmission planning process, (2) summarize substantive study results if available, (3) present drafts of documents, and (4) receive Stakeholder comments on the overall transmission plan.
5. OASIS Information: Black Hills will post and maintain on its OASIS: (1) instructions, meeting notices points of contact, and other information necessary to participate in the TCPC meeting, or other means established for the purpose of soliciting the input of or coordinating with interested Stakeholders; (2) Written comments received from interested Stakeholders, to the extent such comments are not confidential or subject to privilege; and (3) any draft LTP or any other documents Black Hills deems necessary to promote coordination in the LTP study process. A complete list of OASIS posting requirements is defined in Section II.F of Attachment K.

E. Information Exchange

1. Types of Forecast Data: Stakeholders will submit annually information regarding their needs and proposed expansion plans to facilitate the LTP planning process. The obligation to make such submittals will not replace or supersede any requirements related to service or interconnection requests of point-to-point Transmission Customers and Network Customers or interconnected generators under other relevant sections and appendices of this OATT. To facilitate the LTP, the Transmission Customer will provide Black Hills the following types of data during the first quarter of every year per the schedule posted on Black Hillss' OASIS:
 - a. Historical Data: monthly historical energy, peak load and minimum load data for the prior calendar year and the historical energy, peak load, and minimum load data for all months of the current year as it becomes available.
 - b. Load Forecast Data: Network Transmission Customer will provide their ten (10) year monthly energy, peak load and resource and minimum load and resource forecast data.
 - c. Point-to-point and other Transmission Customers: To maximize the effectiveness of the transmission planning process, it is essential that all other Transmission Customers provide their ten (10) year forecast of its projected use of rollover rights of existing reservations and any expected additional reservations. The forecast will specify the Point of Receipt and Point of Delivery at the bust level.
 - d. Generation Forecast Data: Stakeholders will provide data from their own generators including, but not limited to, technical engineering

data for their generators and interconnection facilities, peak capability (MW) and expected maintenance schedule.

- e. Demand Response Resource, Demand Reduction, Conservation and Demand-side Management: Stakeholders will provide demand response resource savings, conservation savings, and other customer load reduction alternatives that would reduce or alter the load of the Transmission Customer.
 - f. Interruptible and Other: Stakeholders will be asked to supply a peak load forecast with and without the interruptible load portion of the forecast data applied.
 - g. Other Supply Sources: Stakeholders will provide monthly energy and peak data for electrical supply sources not from Generators including, but not limited to, point of receipt and point of delivery.
2. Peak Load Forecast Temperature Adjustment: Black Hills may request the temperature adjustment methodology to adjust the winter and summer peak load forecasts to an alternative (e.g., 1-in-2, 1-in-10 and 1-in-20) probability assumption.
 3. Additional Information: Stakeholders will also provide, upon reasonable request, to Black Hills the following information or other information as requested by Black Hills:
 - a. Discussion of reasons for significant increase or decreases in load or generation forecast.
 - b. Source and vintage of load forecast and generation resource information.
 - c. Interruptible OATT loads and demand response resources.
 - d. Weather assumptions associated with load forecasts.
 4. Eligible Customers will submit Economic Study Requests no later the end of the first quarter annually. Requests received after this time will be considered in the following annual study cycle.
 5. Stakeholder Obligation: Stakeholders will provide Black Hills with generation, energy, peak and minimum load forecast, and demand response resources to the maximum extent practical and consistent with protection of proprietary information.
 - a. Stakeholders will provide timely written notice (including email) of material changes to information previously provided relating to its load, resources, or other aspects of its facility or operations affecting

Black Hills' ability to provide service.

- b. If any Stakeholder fails to provide data or otherwise participate as required by this Attachment K, Black Hills cannot effectively include future needs in Black Hills' LTP planning obligations. If any Stakeholder fails to provide data or otherwise participate as required by this Attachment K, Black Hills will plan the system based on the most recent load and resource data received.
6. Comparability of Data: The same type of data request will be sent by Black Hills to all customers within Black Hills' respective area of responsibility. Black Hills will include all valid data, along with appropriate comments on data received from Transmission Customers and Stakeholders.
7. Confidentiality: Individual customer data will be treated as confidential and will be aggregated with other customer data for planning and reporting purposes. The data received will be used to develop Black Hills' LTP and for reporting purposes.
8. Identification of Documents: Stakeholders and Black Hills will identify confidential documents or market sensitive information supplied during the transmission planning process. Any Stakeholder or transmission provider seeking access to such confidential information must agree to adhere to the terms of a confidentiality agreement and have a "need to know". The form of Black Hills' confidentiality agreement will be developed initially by Black Hills and posted on the OASIS. Thereafter, Stakeholders will have an opportunity to submit comments on the form of confidentiality agreement.
9. Protection of Information: Market sensitive and commercial specific or other data, identified as such by the Transmission Customer will be considered confidential. Confidential information will be disclosed in compliance with Standards of Conduct, and only to those participants in the planning process that require such information and that execute the confidentiality agreement; provided, however, any such information may be supplied to (i) federal, state or local regulatory authorities that request such information and protect such information subject to non-disclosure regulations, or (ii) upon order of a court of competent jurisdiction.
10. Schedule of Collection: Black Hills will submit a request for forecast data annually, but no later than the close of business Friday of the second full week of January, and merge it into the annual LTP study schedule as posted on OASIS. Similarly, Black Hills will post on the OASIS instructions, procedures and requirements for the submission of data.

F. Transparency

1. OASIS Requirements

- a. Black Hills will maintain a “Transmission Planning” folder on the publicly accessible portion of its OASIS to distribute information related to this Attachment K. Business Practices and other information pertaining to the LTP will also be posted in the “Transmission Planning” folder.
- b. Black Hills will maintain in the “Transmission Planning” folder on the publicly accessible portion of OASIS a subscription service or “How-To-Contact-Us” folder whereby any person may contact Black Hills to receive e-mail notices, materials related to the LTP process or provide comments to the local transmission planning process.
- c. Content of OASIS Postings. Black Hills will post in the “Transmission Planning” folder on its OASIS:
 - (i) Transmission planning business practices along with the procedures for modifying the business practices;
 - (ii) Study cycle timeline and data submittal schedule;
 - (iii) Each Economic Study Request, and any response from Black Hills;
 - (iv) A summary of information discussed at each TCPC meeting, or other similar meeting related to transmission planning;
 - (v) In advance of its discussion at any TCPC meeting, all materials to be discussed;
 - (vi) Written comments submitted in relation to the LTP;
 - (vii) The draft, interim (if any), and final versions of the current LTP and non-confidential supporting documents;
 - (viii) The final version of all completed Local Transmission Plans for previous study periods;
 - (ix) Economic Study results;
 - (x) Aggregated load forecasts representing Black Hills’ transmission system;
 - (xi) Information regarding the status or material change of upgrades identified in the LTP;
 - (xii) Material database changes noted in Section II.F.2 below;

- (xiii) Summary list of CEII submitted during the planning process;
and
 - (xiv) A link to websites with key information concerning the
CCPG or WestConnect planning process.
2. Database Access and Changes. A Stakeholder may receive access from Black Hills to the database and all changes to the database used to prepare the LTP according to the database access rules established by the WECC and upon certification to Black Hills that the Stakeholder is permitted to access such database. Unless expressly ordered to do so by a court of competent jurisdiction or regulatory agency, Black Hills has no obligation to disclose database information to any Stakeholder that does not qualify for access. Material changes or updates to the database used for the LTP, and reasons for the changes will be posted on Black Hills' OASIS website.

G. Cost Allocation

1. Obligations: Cost allocation principles expressed here do not supersede cost obligations as determined by other parts of the OATT which include but are not limited to transmission service requests, generation interconnection requests, Network Upgrades or Direct Assigned Facilities. Nothing contained in this Attachment K will relieve or modify the obligations of Black Hills or Transmission Customer Pursuant to the OATT.
2. Cost Allocation for New Projects
- a. Black Hills will utilize a case-by-case approach to allocate costs for new projects. This approach will be based on the following principals:
 - (i) Open Season Solicitation of Interest: For any project identified in a transmission provider planning study (for reliability and/or economic projects) in which Black Hills is the project sponsor, Black Hills may elect to provide an "open season" solicitation of interest to secure additional project participants. Upon a determination by Black Hills to hold an open season solicitation of interest for a project, Black Hills will:
 - (a) Announce and solicit interest in the project through informational meetings, its website and/or other means of dissemination as appropriate.
 - (b) Hold meetings with interested parties and meetings with public utility staffs from potentially affected states.

- (c) Post information via WECC's planning project review reports.
 - (d) Develop the initial project specifications, the initial cost estimates and potential transmission line routes; guide negotiations and assist interested parties to determine cost responsibility for initial studies; guide the project through the applicable line siting processes; develop final project specifications and costs; obtain commitments from participants for final project cost shares; and secure execution of construction and operating agreements.
- (ii) Black Hills Coordination within a Solicitation of Interest Process: Black Hills, whether as a project sponsor or a participant will coordinate as necessary with any other participant or sponsor, as the case may be, to integrate into Black Hills' LTP any planned project on or interconnected with Black Hills' system.
 - (iii) Black Hills Projects without a Solicitation of Interest: Black Hills may elect to proceed with small and/or reliability projects without an open season solicitation of interest, in which case Black Hills will proceed with the project pursuant to its rights and obligations as Black Hills.
 - (iv) Allocation of Costs:
 - (a) Proportional Allocation: For any project entered into where an open season solicitation process has been used, project costs and associated transmission rights would generally be allocated proportionally to project participants subject to approval of the participation agreement by FERC. In the event the open season process results in a single participant, the full cost and transmission rights will be allocated to that participant.
 - (b) Economic Benefits or Congestion Relief: For a project wholly on Black Hills' system that is undertaken for economic reasons or congestion relief at the request of a Requestor, the project costs will be allocated to the Requestor.
 - (c) Black Hills Rate Recovery: Notwithstanding the foregoing provisions, Black Hills will not assume cost responsibility for any project if the cost of the

project is not reasonably expected to be recoverable in its retail and/or wholesale rates.

3. Regional Cost Allocation: The cost allocation for regional projects will be allocated consistent with the cost allocation principles of WestConnect (see Attachment K Hyperlink List <http://www.oatioasis.com/bhct/>) posted on Black Hills OASIS).

H. Economic Planning Studies

1. Review: As part of the study cycle described in Section II.F.2 above, Black Hills will review Economic Study Requests. An Economic Study Request involves an assessment to determine whether transmission upgrades can reduce the overall cost of service to Native Load Customers and the load of other customers taking service under the OATT. Black Hills currently does not separately conduct economic planning studies and does not have the individual capability to conduct economic analyses, and thus, in the event of a request for an economic study, may contract with a qualified third party of its choosing to perform such work. Black Hills will coordinate with the TCPC during the annual study cycle to identify and prioritize all Economic Study Requests and perform an assessment to determine if the Economic Study Request would reduce the overall cost of service to Native Load Customers and the load of other customers taking service under the OATT.
2. Request Form: A Stakeholder may make an Economic Study Request by completing the Economic Study Request form located on Black Hills OASIS <http://www.oatioasis.com/bhct/> within the “Transmission Planning” folder. Study requests are due to Black Hills per the official timeline as posted on Black Hills’ OASIS.
3. Number of Studies: Black Hills or its Agent will study up to one (1) high priority Local Transmission Provider Economic Study annually.
4. Classification of Requests. Black Hills, with input from the TCPC, will classify a request for Economic Planning Studies as a Local Transmission Provider Economic Planning Request, Sub-Regional Economic Planning Request, or Regional Economic Planning Request.
 - a. A study request that is confined to Black Hills’ system and does not materially affect the interconnected transmission system, and remedies are confined to the local transmission system, will be considered a Local Transmission Provider Economic Planning Request and studied by Black Hills or its Agent.
 - b. All other Economic Study Requests will be deemed sub-regional or regional requests and be forwarded to WECC TEPPC for inclusion in the WECC TEPPC Economic Planning Study Master List (see Attachment K Hyperlink List <http://www.oatioasis.com/bhct/> posted on Black Hills OASIS) and for consideration as a priority request at WECC TEPPC’s stakeholder meeting. The criteria utilized by WECC TEPPC to prioritize study requests are contained

in its Transmission Planning Protocol (see Attachment K Hyperlink List <http://www.oatioasis.com/bhct/> posted on the Black Hills OASIS).

5. Priority of Requests: Black Hills will identify up to one (1) high priority Local Transmission Provider Economic Planning Request for study for the purpose of alleviating congestion through the integration of new supply and demand resource into the local transmission grid or expanding the local transmission system.
 - a. Sponsors of Economic Planning studies not prioritized as a high priority study may re-submit the Economic Study Request for study consideration in the next economic planning cycle or may fund the study as an Additional Economic Study.
6. Economic Study Process: Black Hills or its Agent will study valid requests for Economic Planning Studies in a manner that is open, transparent and coordinated with Stakeholders utilizing the TCPC or other method established by Black Hills. The economic study timeline and process is further defined in Attachment K Business Practices located on Black Hills OASIS.
7. Economic Study Contents: Black Hills Economic Studies will include, but not be limited to: the location and magnitude of congestion, possible congestion remedies and the cost of relieving congestion.
8. Customer Obligation to Share Data: Transmission Customers requesting an economic Study will, upon request of Black Hills, supply all relevant information necessary to perform the economic study. If the Transmission Customer fails to provide the information requested, Black Hills will have no obligation to complete the study.
9. Additional Economic Studies: Economic study requests that are not prioritized as the highest priority local study will be referred to as Additional Studies. The Transmission Customer or sponsor will pay for actual costs to perform Additional Studies. The process, procedure, and methodology for processing Additional Economic Studies are further defined in Attachment K Business Practices located on Black Hills OASIS.
10. Recovery of Planning Costs: The costs to complete a high priority Black Hills Economic Planning Study will be recovered through the Black Hills' transmission rate base. The cost for Additional Economic Studies will be borne by the sponsor of the Economic Study Request.
11. Clustering of Economic Study Requests: Black Hills may determine that any number of Economic Study Requests should be studied together, or a Study Requestor may request that Black Hills study its request together with other requests. Black Hills will consider the following criteria in

determining whether or not to cluster multiple Black Hills Economic Planning Requests which have been identified as high priority by Black Hills through coordination with the TCPC:

- a. All submitted Black Hills Economic Planning Requests designated as high priority will be evaluated by Black Hills to determine if the requests can be feasibly and meaningfully studied as a group taking into account the scope of the requests from an electrical perspective.
- b. Upon the decision of Black Hills to include the evaluated high priority Local Transmission Provider Economic Planning Requests into a clustered study, Black Hills will provide the Requestor notice of proposed inclusion of its request within a clustered study. The Requestor will be given the opportunity to opt-out of the clustered study by providing written notice to Black Hills within ten business days of notice of inclusion in the proposed clustered study.
- c. Should a Requestor wish to cluster its request with other Black Hills Economic Planning Requests, it must provide to Black Hills written consent of all Requestors whose requests would be included in the proposed clustered study. Black Hills reserves the right to reject a Requestor proposed clustered study on any reasonable grounds. Black Hills must determine whether to reject the proposed clustered study and provide written notice of rejection to all participating Requestors within twenty (20) business days.

I. Dispute Resolution

1. Process: If a dispute arises concerning either a procedural or substantive matter within the jurisdiction of FERC, the following dispute resolution process will apply:
 - a. WECC: If the dispute is one that is within the scope of the WECC dispute resolution procedures, then such procedures will apply.
 - b. Non-WECC Disputes: For disputes not within the scope of the WECC dispute resolution procedures, the dispute resolution procedures set forth in Section 12 of the OATT will apply, with the added provision that upon agreement of the parties, any dispute that is not resolved by direct negotiation between or among the affected parties within a reasonable period of time, may be referred to mediation (before or during arbitration), and all applicable timelines will be suspended until such time as the mediation process terminates (unless otherwise agreed by the parties). Notwithstanding that the dispute resolution procedures under Section 12 of the OATT apply only to Black Hills and Transmission Customers, Section 12 of the OATT will be deemed to be applicable

to Stakeholders for purposes of this Attachment K.

- c. Notwithstanding anything to the contrary in this Section 2.7, any affected party may refer the matter to FERC for resolution at any time, for example, by filing with FERC a complaint, a request for declaratory order or a change in rate.

J. Transmission Business Practices

Black Hills has posted on its OATT website (<http://www.oatioasis.com/bhbe/>): (1) the “Attachment K Business Practice” which provides additional information regarding the implementation of this Attachment K; and (2) the “Transmission Provider Methodology Criteria and Process Business Practice” which provides additional information related to Principle 4, Transparency.

K. Planning for Public Policy Requirements in the Local Planning Process

1. Procedures for Identifying Transmission Needs Driven by Public Policy Requirements

Stakeholders may participate in identifying local transmission needs driven by Public Policy Requirements by contacting Black Hills’ Manager of Transmission Planning as listed on Black Hills’ OASIS. In addition, stakeholders have the opportunity to offer input or make proposals at Black Hills’ open meetings held pursuant to this Attachment K.

The process by which Black Hills is to identify those local transmission needs driven by Public Policy Requirements for which a local transmission solution(s) will be evaluated, out of what may be a larger set of local transmission needs, is to utilize the two communication channels it has in place with stakeholders, identified above, through which local transmission needs driven by Public Policy Requirements are to be part of the open dialogue: (a) direct communication with Black Hills’ designated point of contact identified above, through which a stakeholder desiring to communicate directly with Black Hills transmission planners may offer its views on which local transmission needs are ripe for evaluation for solutions, and (b) through participation in Black Hills’ open meetings held pursuant to this Attachment K.

In selecting those local transmission needs driven by Public Policy Requirements that will be evaluated for solutions in the current planning cycle, Black Hills is to consider, on a non-discriminatory basis, factors, including but not limited to, the following:

- (i) Whether the Public Policy Requirement is driving a local transmission need that can be reasonably identified in the current planning cycle;

- (ii) the feasibility of addressing the local transmission need driven by the Public Policy Requirement in the current planning cycle;
- (iii) the factual basis supporting the local transmission need driven by the Public Policy Requirement; and
- (iv) whether a Public Policy Requirement has been identified for which a local transmission need has not yet materialized, or for which there may exist a local transmission need but the development of a solution to that need is premature. One example is a renewables portfolio increase that is enacted for implementation in a future year, and for which the process by which the renewable resource is to be identified, selected, and sited under the governing state-regulated resource adequacy process has not yet begun (making it premature to identify the location and scope of the local transmission need and/or the appropriate solution for the need).

No single factor shall necessarily be determinative in selecting among the potential transmission needs driven by Public Policy Requirements.

Black Hills is not required to identify any particular set of local transmission needs driven by Public Policy Requirements, but if Black Hills chooses not to identify any stakeholder-suggested local transmission need driven by a Public Policy Requirement as a transmission need for which solutions will be evaluated in the local transmission planning process, Black Hills will post on its OASIS an explanation of why the suggested transmission need will not be evaluated. Black Hills' OASIS posting will include both an explanation of those local transmission needs driven by Public Policy Requirements that have been identified for evaluation for potential solutions in the local transmission planning process, and an explanation why other stakeholder-suggested transmission needs driven by Public Policy Requirements were not identified for further evaluation. After considering the input of stakeholders, Black Hills is to determine whether to move forward with the identification of a local solution to a particular local need driven by Public Policy Requirements.

2. Procedures for Evaluating Solutions to Identified Transmission Needs

Stakeholders may use the two communication avenues identified above (direct communication with Black Hills' planning staff and/or participation in Black Hills' open meetings) to participate in the evaluation of solutions to identified local transmission needs driven by Public Policy Requirements that are selected by Black Hills for further evaluation. Stakeholders may provide comments on proposed solutions or may submit other proposed solutions to such local transmission needs.

After seeking the input of stakeholders, Black Hills is to determine whether to select a particular local solution in its local transmission plan. Black Hills will post its local transmission plan, which will include any such solutions selected.

The procedures for evaluating potential solutions to the identified local transmission needs driven by Public Policy Requirements are the same as those procedures used to evaluate any other project proposed in the local planning process.

3. Posting of Public Policy Needs

Black Hills will maintain on its OASIS (i) a list of all local transmission needs identified that are driven by Public Policy Requirements and that are included in the studies for the current local planning cycle; and (ii) an explanation of why other suggested transmission needs driven by Public Policy Requirements will not be evaluated.

III. Regional Planning Process

In accordance with the Commission's regulations, this Attachment K to the OATT meets the requirements for regional planning in accordance with Order No. 1000 and Order No. 890. Black Hills engages in regional Planning and Coordination within the WestConnect regional process ("Regional Planning Process").

The purpose of the Regional Planning Process is to produce a regional transmission plan (the Regional Plan) and provide a process for evaluating projects submitted for cost allocation in accordance with the provisions of this Attachment K and those business practices adopted by WestConnect in the WestConnect Regional Planning Process Business Practice Manual, as may be amended from time to time, available on the WestConnect website (Business Practice Manual).

Black Hills actively participates in the CCPG and WestConnect planning processes to ensure that Black Hills' local transmission plans, together with data and assumptions, are included in and coordinated with any applicable subregional or regional transmission plans.

A. Overview

The WestConnect Planning Region is defined by the transmission owners and transmission provider members (referred to generally as "transmission owners") participating in the Regional Planning Process, and for whom WestConnect is conducting regional planning. The service areas of the transmission providers consist of all or portions of nine states: Arizona, California, Colorado, Nebraska, Nevada, New Mexico, South Dakota, Texas and Wyoming. Non-public utilities are invited to participate in the Regional Planning Process.

Following the effective date of Black Hills' September 20, 2013 Order No. 1000 compliance filing (Effective Date), the WestConnect Order No. 1000

regional transmission planning management committee (PMC) will commence the Regional Planning Process. This committee will be responsible for administering the Regional Planning Process. In order to align its regional process with the western interregional coordination process, it is WestConnect's intent to begin its biennial process in even-numbered years. Should FERC acceptance of WestConnect's compliance filing result in an effective date in an odd-numbered year, WestConnect will conduct an abbreviated planning process in its first year and begin its biennial process the next year. To effectuate such an abbreviated process, the PMC will develop a study scope for the first year, including project submission deadlines, and post it to the WestConnect website within the first thirty (30) days of the year.

In conjunction with creating the new PMC, the WestConnect members, in consultation with interested Stakeholders, will establish a separate project agreement (the "Planning Participation Agreement") to permit interested Stakeholders to participate in the Regional Planning Process. Although the Regional Planning Process is open to the public, Stakeholders interested in having a voting right in decisions related to the Regional Planning Process will be required to execute the Planning Participation Agreement and any necessary confidentiality agreements.² The PMC will implement the Stakeholder-developed Regional Planning Process, which will result in a Regional Plan for the ten-year transmission planning horizon.³

Black Hills is a party to the WestConnect Project Agreement for Subregional Transmission Planning ("WestConnect STP Project Agreement") (See Black Hills Attachment K Hyperlinks List posted on the BHBE OASIS <http://www.oatioasis.com/bhct/>). The committees formed under the WestConnect STP Project Agreement and the WestConnect Steering Committee have no authority over the PMC and the PMC's decision making in implementing the Regional Planning Process.

2. If the Planning Participation Agreement is terminated, the requirement of becoming a signatory to the Planning Participation Agreement also terminates. In that situation, it would no longer be necessary for an entity to execute the Planning Participation Agreement before engaging in the WestConnect regional planning process, because the PMC will cease performing its functions under this Attachment K upon termination of the Planning Participation Agreement.

3. Because the rights and responsibilities of the PMC terminate when the Planning Participation Agreement terminates, Black Hills, as a Transmission Provider subject to Order No. 1000 compliance, will have to satisfy its regulatory compliance through other means. At that time, Black Hills will make an appropriate filing with the Commission to demonstrate its continued compliance with Order No. 1000.

1. WestConnect Planning Participation Agreement

Each WestConnect member will be a signatory to the Planning Participation Agreement, which formalizes the members' relationships and establishes

obligations, including transmission owner coordination of regional transmission planning among the WestConnect participants and the local transmission planning processes, and produce a Regional Plan.

2. Members

WestConnect has two general types of members: (i) transmission owners that enroll in WestConnect to comply with the Order No. 1000 planning and cost allocation requirements, as well as transmission owners that elect to participate in the Regional Planning Process without enrolling for Order No. 1000 cost allocation purposes; and (ii) stakeholders who wish to have voting input on the methodologies, studies and decisions made in the execution of the Order No. 1000 requirements.:

a. Joining the WestConnect Planning Region.

A transmission owner that wishes to enroll or participate in the WestConnect Planning Region may do so by executing the Planning Participation Agreement and paying its share of costs as provided for in the Planning Participation Agreement.

A stakeholder that wishes to have voting input may join the WestConnect Planning Region by executing the Planning Participation Agreement, paying annual dues, and complying with applicable provisions as outlined in such agreement. For further information regarding membership dues, please see WestConnect's Planning Participation Agreement, located on the WestConnect website⁴ and on file with FERC.

b. Exiting the WestConnect Planning Region.

Should a transmission owner wish to exit the WestConnect Planning Region, it must submit notice in accordance with the Planning Participation Agreement and pay its share of any WestConnect Planning Region expenditures approved prior to the effective date of the formal notice of withdrawal from the WestConnect Planning Region.

4. The WestConnect Planning Participation Agreement is located at:
<http://www.westconnect.com/planning_agreement.php>.

Should a stakeholder wish to exit the WestConnect Planning Region, it may do so by providing notice in accordance with the Planning Participation Agreement. Withdrawing stakeholders will forfeit any monies or dues paid to the PMC and agree to remit to the

PMC any outstanding monies owed to the committee on or prior to the effective date of such withdrawal.

c. List of Enrolled Entities.

Transmission owners enrolled in the WestConnect Planning Region for purposes of Order No. 1000:

- Arizona Public Service Company
- Black Hills Colorado Electric, LLC
- Black Hills Power, Inc.
- Cheyenne Light, Fuel, & Power Company
- El Paso Electric Company
- NV Energy, Inc. Operating Companies
- Public Service Company of Colorado
- Public Service Company of New Mexico
- Tucson Electric Power Company
- UNS Electric, Inc.

3. WestConnect Objectives and Procedures for Regional Transmission Planning

The Regional Planning Process will produce a Regional Plan that complies with existing Order No. 890 principles and carried forward in Order No. 1000:

- Coordination
- Openness
- Transparency
- Information exchange
- Comparability
- Dispute Resolution

Black Hills, along with the other Planning Participation Agreement signatories, will work through the regional planning group processes, as applicable, to integrate their transmission plans into a single, ten year Regional Plan for the WestConnect Planning Region by:

- a. Actively coordinating development of the Regional Plan, including incorporating information, as appropriate, from all stakeholders;
- b. Coordinating, developing and updating common base cases to be

used for all study efforts within the Regional Planning Process and ensuring that each plan adheres to the methodology and format developed for the Regional Plan;

- c. Providing funding for the Regional Planning Process and all planning management functions pursuant to the Planning Participation Agreement;
- d. Maintaining a regional planning section on the WestConnect website where all WestConnect planning information, including meeting notices, meeting minutes, reports, presentations, and other pertinent information is posted;
- e. Posting detailed notices of all regional and local planning meeting agendas on the WestConnect website; and
- f. Establishing a cost allocation process for regional transmission projects selected in the Regional Planning Process for cost allocation.

B. Roles in the Regional Transmission Planning Process

1. PMC Role

The PMC is responsible for bringing transmission planning information together and sharing updates on active projects. The PMC provides an open forum where any Stakeholder interested in the planning of the regional transmission system in the WestConnect footprint can participate and obtain information regarding base cases, plans, and projects and provide input or express its needs as they relate to the transmission system. On a biennial basis and in coordination with its members, Transmission Owners, and other interested stakeholders, the PMC will develop the Regional Plan. The PMC, after considering the data and comments supplied by customers and other stakeholders, is to develop a regional transmission plan that treats similarly-situated customers (e.g., network, retail network, and native load) comparably in transmission system planning.

The PMC is charged with development and approval of the Regional Plan. The PMC will be comprised of representatives from each stakeholder sector, as described in Section III.B.5, below. The PMC will be empowered to create and dissolve subcommittees as necessary to facilitate fulfillment of its responsibilities in developing the Regional Plan.

2. Stakeholder Participation and Assistance

Stakeholders may participate in the Regional Planning Process in any one or more of the following ways: (a) by joining one of five WestConnect regional transmission planning membership sectors described below; (b) by

attending publicly-posted WestConnect regional transmission planning stakeholder meetings; and/or (c) by submitting project proposals for consideration and evaluation in the Regional Planning Process.

Attendance at meetings is open to all interested Stakeholders. These meetings will include discussion of models, study criteria and assumptions, and progress updates. Formal participation, including voting as allowed by the process, can be achieved through payment of applicable fees and annual dues in accordance with the Planning Participation Agreement. Transmission Owners with a Load Serving Obligation will not be responsible for annual dues because they will be the default source of monies to support WestConnect activities beyond dues paid by other organizations.

WestConnect Planning Region members will assist stakeholders interested in becoming involved in the Regional Transmission Planning process by directing them to appropriate contact persons and websites. (See BHP Attachment K Hyperlinks List posted on the BHBE OASIS [http://www.oatioasis.com/BHCT/BHCTdocs/BHCT_Hyperlinks_List.pdf]). All stakeholders are encouraged to bring their plans for future generators, loads or transmission services to the WestConnect regional planning meetings. Each transmission planning cycle will contain a period during which project ideas are accepted for potential inclusion in that cycle's Regional Plan.

3. Forum for Evaluation

The Regional Planning Process provides a forum for transmission project sponsors to introduce their specific projects to interested stakeholders and potential partners and allows for joint study of these projects by interested parties, coordination with other projects, and project participation, including ownership from other interested parties. This may include evaluation of transmission alternatives or non-transmission alternatives in coordination with the Regional Planning Process.

4. Stakeholder Meetings

WestConnect will hold open stakeholder meetings on at least a semi-annual basis, or as needed and noticed by the PMC with thirty (30) days advance notice to update Stakeholders about its progress in developing the WestConnect Regional Transmission Plan and to solicit input regarding material matters of process related to the regional transmission plan. Notice for such meetings will be posted on the WestConnect website and via email to the WestConnect Regional Transmission Planning email distribution list.

The meeting agendas for all WestConnect planning meetings will be sufficiently detailed, posted on the WestConnect website, and circulated in

advance of the meetings in order to allow Stakeholders the ability to choose their meeting attendance most efficiently.

5. WestConnect Planning Governance Process

a. Membership Sectors

The Regional Planning Process will be governed by the PMC, which will be tasked with executing the Regional Planning Process and will have authority for approving the Regional Plan. For those entities desiring to be a part of the management of the Regional Planning Process, one of five PMC membership sectors is available

- Transmission Owners with Load Serving Obligations
- Transmission Customers
- Independent Transmission Developers and Owners
- State Regulatory Commissions

Key Interest Groups

Only transmission owners that have load serving obligations individually or through their members may join the Transmission Owners with Load Serving Obligations membership sector. The Transmission Owners with Load Serving Obligations sector will be comprised of (a) those transmission owners that enroll in the WestConnect Planning Region for purposes of Order No. 1000; and (b) those transmission owners that elect to participate in the Regional Planning Process as Coordinating Transmission Owners.

Except for Public Utilities that are required to comply with Order No. 1000, any entity may join any membership sector for which it qualifies, but may only participate in one membership sector at a time. If a non-public utility is qualified to join the Transmission Owners with Load Serving Obligations sector as well as one or more other sectors, and the non-public utility elects to join a sector other than the Transmission Owners with Load Serving Obligations sector, the PMC will not perform the function of regional transmission planning for that entity. Additionally, if a member of the Transmission Owner with Load Serving Obligations sector owns transmission facilities located in another planning region, the PMC will not perform the function of regional planning for such facilities located in another planning region.

b. Planning Management Committee

The PMC will be empowered to create and dissolve subcommittees as necessary to ensure timely fulfillment of its responsibilities; to assess fees for membership status on the PMC; and to assess fees for projects submitted for evaluation as part of the Regional Planning Process. The PMC is to manage the Regional Planning Process, including approval of the Regional Plan that includes application of regional cost allocation methodologies.

The PMC is to coordinate and have the decision-making authority over whether to accept recommendations from the Planning Subcommittee (PS) and Cost Allocation Subcommittee (CAS). The PMC, among other things, is to develop and approve the Regional Plan based on recommendations from the PS and CAS; and develop and approve a scope of work, work plan, and periodic reporting for WestConnect planning functions, including holding a minimum of two stakeholder informational meetings per year. The PMC is to appoint the chair of the PS and CAS. The chair for each subcommittee must be a representative of the Transmission Owners with Load Serving Obligations member sector.

The PS responsibilities include, but are not limited to, reviewing and making recommendations to the PMC for development of study plans, establishing base cases, evaluating potential solutions to regional transmission needs, producing and recommending the Regional Plan for PMC approval and coordinating with the CAS. The PS is to provide public notice of committee meetings and provide opportunities for stakeholders to provide comments on the process and proposed plan.

The CAS responsibilities include, but are not limited to, performing and/or overseeing the performance of the cost allocation methodology. The CAS also is to review and make recommendations to the PMC for modifying definitions of benefits and cost allocation methodology as necessary to meet WestConnect planning principles on identification of beneficiaries and cost allocation. The CAS is to review and recommend projects to the PMC for purposes of cost allocation identified in the Regional Planning Process. The CAS is to provide public notice of committee meetings and provide opportunities for stakeholders to provide comments on the process and proposed cost allocation.

All actions of the PMC (including approval of the Regional Plan) will be made possible by satisfying either of the following requirements:

75% of the members voting of at least three sectors approving a motion, where one of the three sectors approving is the Transmission Owners with Load Serving Obligations sector:
or

75% of the members voting of the four member sectors other than the Transmission Owners with Load Serving Obligation sector approving a motion and two-thirds (2/3) of the members voting of the Transmission Owners with Load Serving Obligations sector approving a motion.

Each entity within a membership sector is entitled to one vote on items presented for decision.

Any closed executive sessions of the PMC will be to address matters outside of the development of the Regional Planning Process, including matters involving contracts, personnel, financial matters, or legal matters such as, but not limited to, litigation (whether active or threatened).

C. Submission of Data by Customers, Transmission Developers, and Transmission Owners

When stakeholder feedback on modeling assumptions is requested, the data submittal period for such feedback will be established by the PMC. In all cases, requests for submittal of data from WestConnect members and stakeholders will be followed by a data submittal window lasting no less than thirty (30) days from the date of such requests. In addition, consistent with the Regional Planning Process, any interested stakeholder may submit project ideas for consideration in the WestConnect Regional Transmission Plan without a need for that stakeholder to qualify for a project submittal for purposes of cost allocation. Specific project submittals are treated differently than generalized project ideas. For any project submittal seeking study by the PMC in the Regional Planning Process to address a regional need identified by the PMC (without regard to whether the project seeks cost allocation), a project submittal deposit will be collected and made subject to later true-up based upon the actual cost of the study (ies) performed. Project submittals are to be accepted through the fifth (5th) quarter of the planning cycle (or first (1st) quarter of the second (2nd) year), and are addressed in Section III.C.5 of this Attachment K. A timeline detailing the timing and notice for submission of information and input can be found in Exhibit 1 of this Attachment K.

1. Transmission Customers

Transmission customers shall generally submit their load forecast and other relevant data through the WestConnect Planning Region member's local transmission planning process. However, from time to time, there may be a need for transmission customers participating in the Regional Planning

Process to submit data directly to WestConnect. This data may include, but is not limited to load forecasts, generation resource plans, demand side management resources, proposed transmission upgrade recommendations, and feedback regarding certain assumptions in the planning process.

No less than thirty (30) days' notice will be given for customers to submit any required data and data submissions will generally be able to be made via email or by posting information to a designated website.

2. Independent Transmission Developers and Owners

Transmission Developers are entities with project ideas they wish to submit into the Regional Planning Process. These may include project submittals that the developer wishes to be considered to address an identified regional need (whether or not the project is eligible for regional cost allocation).

Each regional transmission planning cycle will include a submission period for projects, as described below. Notice of the submission period will be posted on the WestConnect website and will also be made via email to WestConnect stakeholders. The submission period will last for no less than thirty (30) days and during this time, any entity that wishes to submit a transmission project for consideration in the Regional Planning Process to address an identified regional need may do so.

Projects proposed by Independent Transmission Developers and Owners are subject to the same reliability standards as projects submitted by Transmission Owners with Load Serving Obligations. The project developer shall register with NERC and WECC in accordance with the applicable registration rules in the NERC Rules of Procedure. In addition, project developers shall observe and comply with regional requirements as established by the applicable regional reliability organizations, and all local, state, regional, and federal requirements.

3. Merchant Transmission Developers

Merchant Transmission Developers are entities pursuing completion of projects that do not wish to have their projects considered for regional cost allocation. Nonetheless, coordination between merchant projects and the Regional Planning Process is necessary to affect a coordinated Regional Plan that considers all system needs.

Each regional transmission planning cycle will include a submission period for project submittals to address an identified regional need as described below. Notice of the submission period will be posted on the WestConnect website and will also be made via email to WestConnect stakeholders. In addition, it is necessary for merchant transmission developers to provide adequate information and data to allow the PMC to assess the potential reliability and operational impacts of the merchant transmission developer's

proposed transmission facilities on other systems in the region. The submission period will last for no less than thirty (30) days and during this time sponsors of merchant transmission projects that are believed to impact the WestConnect Planning Region will be asked to provide certain project information.

Projects proposed by Merchant Transmission Developers are subject to the same reliability standards as projects submitted by Transmission Owners with Load Serving Obligations. The project developer is responsible for properly registering with NERC and WECC in accordance with the applicable registration rules in the NERC Rules of Procedure. In addition, project developers shall observe and comply with regional requirements as established by the applicable regional reliability organization and all local, state, regional, and federal requirements.

4. Transmission Owners with Load Serving Obligation

Transmission Owners and Transmission Providers that are members of the WestConnect Planning Region are responsible for providing all necessary system information to the Regional Planning Process.

At the beginning of each regional transmission planning cycle, Transmission Owners and Transmission Providers that are participating in the Regional Planning Process will be responsible for verifying the accuracy of any data (including, but not limited to system topology and project proposal information) they have previously submitted. Transmission Owners will also be required to submit all relevant data for any new projects being proposed for inclusion in the Regional Plan to address an identified regional need in accordance with Section III.C.5 below. Transmission Owners will also be responsible for submitting any project plans developed through their local transmission planning processes for inclusion in the Regional Plan models.

5. Transmission Project Submittals

All submittals of transmission projects to address an identified regional need, without regard to whether or not the project seeks regional cost allocation, are to contain the information set forth below, together with the identified deposit for study costs, and be submitted timely within the posted submittal period in order for the project submittal to be eligible for evaluation in the Regional Planning Process. A single project submittal may not seek multiple study requests. To the extent a project proponent seeks to have its project studied under a variety of alternative project assumptions, the individual alternatives must be submitted as individual project submittals. To be eligible to propose a project for selection in the Regional Plan, a project proponent must also be an active member in good standing within one of the five PMC membership sectors described above

in Section III.B.5.a:

- Submitting entity contact information
- Explanation of how the project is a more efficient or cost-effective solution compared to regional transmission needs*
- A detailed project description including, but not limited to, the following:
 - Scope
 - Points of interconnection to existing (or planned) system
 - Operating Voltage and Alternating Current or Direct Current status
 - Circuit Configuration (Single, Double, Double-Circuit capable, etc.)
 - Impedance Information
 - Approximate circuit mileage
- Description of any special facilities (series capacitors, phase shifting transformers, etc.) required for the project
- Diagram showing geographical location and preferred route; general description of permitting challenges
- Estimated Project Cost and description of basis for that cost*
- Any independent study work of or relevant to the project
- Any WECC study work of or relevant to the project
- Status within the WECC path rating process
- The project in-service date
- Change files to add the project to a standard system power flow model
- Description of plan for post-construction maintenance and operation of the proposed line
- A \$25,000 deposit to support the cost of relevant study work, subject to true-up (up or down) based upon the actual cost of the study(ies).

The true-up will include interest on the difference between the deposit and the actual cost, with such interest calculated in accordance with section 35.19a(a)(2) of FERC's regulations. A description of the costs to which the deposit was applied, how the costs were calculated, and an accounting of the costs will be provided to each project sponsor within 30 calendar days of the completion of the study. Dispute resolution is addressed pursuant to Section V.

- Comparison Risk Score from WECC Environmental Data Task Force, if available
- Impacts to other regions.* The applicant must provide transmission system impacts studies showing system reliability impacts to neighboring transmission systems or another transmission planning region. The information should identify all costs associated with any required upgrades to mitigate adverse impacts on other transmission systems.*

If impact studies and costs are not available at the time of submittal, the project proponent may request that impact studies be performed, at the project proponent's expense, as part of the analysis to determine whether the project is the more efficient or cost-effective solution. Requests for transmission system impact studies are approved through the PMC depending on whether the project proponent provides funding for the analysis. The PMC will provide, subject to appropriate confidentiality and CEII restrictions, the information in the possession of the PMC that an applicant needs to perform the transmission system impact study and to identify the costs associated with any upgrades required to mitigate adverse impacts.

* Merchant transmission developers are exempt from these requirements.

There is to be an open submission period for project proposals to address identified regional needs. Notice of the submission period shall be posted on the WestConnect website and will also be made via email to WestConnect stakeholders. The submission period shall last for no less than thirty (30) days and will end by the fifth (5th) quarter of the WestConnect planning cycle (or first (1st) quarter of the second (2nd) year of the planning cycle). Proposals submitted outside that window will not be considered. The PMC will have the authority to determine the completeness of a project submittal. Project submittals deemed incomplete will be granted a reasonable opportunity to cure any deficiencies identified in writing by the PMC.

Any stakeholder wishing to present a project submittal to address an

identified regional need shall be required to submit the data listed above to be considered in the Regional Planning Process. Should the submitting stakeholder believe certain information is not necessary, it shall identify the information it believes is not necessary and shall provide a justification for its conclusion that the information is not necessary. The PMC retains the sole authority for determining completeness of the information submittal. After the completion of the project submittal period, the PMC will post a document on the WestConnect website detailing why any projects were rejected as incomplete. Upon posting of the document, any project submittal rejected as incomplete will be given a reasonable opportunity to cure the reason(s) it was rejected to the satisfaction of the PMC in its sole discretion.

6. Submission of Non-transmission Alternative Projects.

Any stakeholder may submit projects proposing non-transmission alternatives to address an identified regional need for evaluation under the Regional Planning Process. The submission period will last for no less than thirty (30) days. The submission window will end by the fifth (5th) quarter of the WestConnect planning cycle (or first (1st) quarter of the second (2nd) year of the planning cycle). The following criteria must be satisfied in order for a non-transmission alternative project submittal to be evaluated under the Regional Planning Process:

- Basic description of the project (fuel, size, location, point of contact)
- Operational benefits
- Load offset, if applicable
- Description of the issue sought to be resolved by the generating facility or non-transmission alternative, including reference to any results of prior technical studies
- Network model of the project flow study
- Short-circuit data
- Protection data
- Other technical data that might be needed for resources
- Project construction and operating costs
- Additional miscellaneous data (e.g., change files if available)

As with entities submitting a transmission project under Section III.C.5, those who submit under Section III.C.6 a non-transmission alternative

under the Regional Planning Process must adhere to and provide the same or equivalent information (and deposit for study costs) as transmission alternatives, as described in Section III.C.5, above. Should the submitting stakeholder believe certain information is not necessary, it shall identify the information it believes is not necessary and shall provide a justification for its conclusion that the information is not necessary. Although non-transmission alternative projects will be considered in the Regional Planning Process, they are not eligible for regional cost allocation.

7. The WestConnect Regional Planning Cycle.

The WestConnect regional transmission planning cycle is biennial. The WestConnect PMC will develop and publish a Regional Plan every other year.

D. Transmission Developer Qualification Criteria

1. In General

A transmission developer that seeks to be eligible to use the regional cost allocation methodology for a transmission project selected in the Regional Plan for purposes of cost allocation must identify its technical and financial capabilities to develop, construct, own, and operate a proposed transmission project. To be clear, satisfaction of the criteria set forth below does not confer upon the transmission developer any right to:

- (i) construct, own, and/or operate a transmission project,
- (ii) collect the costs associated with the construction, ownership and/or operation of a transmission project,
- (iii) provide transmission services on the transmission facilities constructed, owned and/or operated.

The applicable governing governmental authorities are the only entities empowered to confer any such rights to a transmission developer. The PMC is not a governmental authority.

2. Information Submittal

A transmission developer seeking eligibility for potential designation as the entity eligible to use the regional cost allocation for a transmission project selected in the Regional Plan for purposes of cost allocation must submit to the PMC the following information during the first quarter of the WestConnect planning cycle, except that during the first WestConnect planning cycle the PMC shall have the discretion to extend the period for the submission of this information:

a. Overview

A brief history and overview of the applicant demonstrating that the applicant has the capabilities to finance, own, construct, operate and maintain a regional transmission project consistent with Good Utility Practice within the state(s) within the WestConnect Planning Region. The applicant should identify all transmission projects it has constructed, owned, operated and/or maintained, and the states in which such projects are located.

b. Business Practices

A description of the applicant's experience in processes, procedures, and any historical performance related to engineering, constructing, operating and maintaining electric transmission facilities, and managing teams performing such activities. A discussion of the types of resources, including relevant capability and experience (in-house labor, contractors, other transmission providers, etc.) contemplated for the licensing, design, engineering, material and equipment procurement, siting and routing, Right-of-Way (ROW) and land acquisition, construction and project management related to the construction of transmission projects. The applicant should provide information related to any current or previous experience financing, owning, constructing, operating and maintaining and scheduling access to regional transmission facilities.

c. Compliance History

The applicant should provide an explanation of any violation(s) of NERC and/or Regional Entity Reliability Standards and/or other regulatory requirements pertaining to the development, construction, ownership, operation, and/or maintenance of electric transmission facilities by the applicant or any parent, owner, affiliate, or member of the applicant that is an Alternate Qualifying Entity (ies) under Section III.D.2.1. Notwithstanding the foregoing, if at the time the applicant submits the information required by this Section III.D.2, the applicant has not developed, constructed, owned, operated or maintained electric transmission facilities, the applicant shall instead submit such information for any electric distribution or generating facilities it develops, constructs owns, operates and/or maintains, as applicable, to demonstrate its compliance history.

d. Participation in the Regional Planning Process

A discussion of the applicant's participation within the Regional Planning Process or any other planning forums for the identification,

analysis, and communication of transmission projects.

e. Project Execution

A discussion of the capability and experience that would enable the applicant to comply with all on-going scheduling, operating, and maintenance activities associated with project development and execution.

f. Right-of-Way Acquisition Ability

The applicant's preexisting procedures and historical practices for siting, permitting, landowner relations, and routing transmission projects including, acquiring ROW and land, and managing ROW and land acquisition for transmission facilities. Any process or procedures that address siting or routing transmission facilities through environmentally sensitive areas and mitigation thereof. If the entity does not have such preexisting procedures, it shall provide a detailed description of its plan for acquiring ROW and land and managing ROW and land acquisition.

g. Financial Health

The applicant must demonstrate creditworthiness and adequate capital resources to finance transmission projects. The applicant shall either have an investment grade credit rating from both S&P and Moody's or provide corporate financial statements for the most recent five years for which they are available. Entities that do not have a credit rating, or entities less than five years old, shall provide corporate financial statements for each year that is available. Alternatively, the applicant may provide a guarantee, a surety bond, letter of credit or other form of security that is reasonably acceptable to the PMC.

The following ratios must be provided with any explanations regarding the ratios:

- Funds from operations-to-interest coverage.
- Funds from operation-to-total debt.
- Total debt-to-total capital.
- The applicant must indicate the levels of the above ratios the company will maintain during and following construction of the transmission element.

The PMC may request additional information or clarification as

necessary.

h. Safety Program

The applicant must demonstrate that they have an adequate internal safety program, contractor safety program, safety performance record and program execution.

i. Transmission Operations

The applicant must: demonstrate that it has the ability to undertake control center operations, including reservations, scheduling, and outage coordination; demonstrate that it has the ability to obtain required path ratings; provide evidence of its NERC compliance process and compliance history, as applicable; demonstration of any existing required NERC certifications or the ability to obtain any applicable NERC certifications; establish required Total Transfer Capability; provide evidence of storm/outage response and restoration plans; provide evidence of its record of past reliability performance, as applicable; and provide a statement of which entity will be operating completed transmission facilities and will be responsible for staffing, equipment, and crew training. A potential transmission developer will not be required to have an operations entity under contract at the time it seeks to be eligible to use the regional cost allocation method for a transmission project selected in the Regional Plan for purposes of cost allocation.

j. Transmission Maintenance

The applicant must demonstrate that they have, or have plans to develop, an adequate transmission maintenance program, including staffing and crew training, transmission facility and equipment maintenance, record of past maintenance performance, NERC compliance process and any past history of NERC compliance or plans to develop a NERC compliance program, statement of which entity will be performing maintenance on completed transmission facilities. A potential transmission developer will not be required to have a maintenance entity under contract at the time it seeks to be eligible to use the regional cost allocation method for a transmission project selected in the Regional Plan for purposes of cost allocation.

k. Regulatory Compliance

The applicant must demonstrate the ability, or plans to develop the ability, to comply with Good Utility Practice, WECC criteria and regional reliability standards, NERC Reliability Standards, construction standards, industry standards, and environmental standards.

1. Affiliation Agreements

A transmission developer can demonstrate that it meets these criteria either on its own or by relying on an entity or entities with whom it has a corporate affiliation or other third-parties with relevant experience (Alternate Qualifying Entity (ies)). In lieu of a contractual or affiliate relationship with one or more Alternate Qualifying Entity (ies) and to the extent a transmission developer intends to rely upon third-parties for meeting these criteria, the transmission developer must provide in attestation form an identification of its preferred third-party contractor(s) and indicate when it plans to enter into a definitive agreement with its third-party contractor(s). If the transmission developer seeks to satisfy the criteria in whole or in part by relying on one or more Alternate Qualifying Entity (ies), the transmission developer must submit: (1) materials demonstrating to the PMC's satisfaction that the Alternate Qualifying Entity (ies) meet(s) the criteria for which the transmission developer is relying upon the alternate qualifying entity (ies) to satisfy; and (2) a commitment to provide in any project cost allocation application an executed agreement that contractually obligates the Alternate Qualifying Entity (ies) to perform the function(s) for which the transmission developer is relying upon the Alternate Qualifying Entity (ies) to satisfy.

m. WestConnect Membership

A transmission developer must be a member of either the WestConnect Transmission Owners with Load Serving Obligations or Independent Transmission Developers and Owners sector, or must agree to join the WestConnect Transmission Owners with Load Serving Obligations or Independent Transmission Developers and Owners sector and agree to sign the Planning Participation Agreement if the transmission developer seeks to be an entity eligible to use the regional cost allocation method for a transmission project selected in the Regional Plan for purposes of cost allocation.

n. Other

Any other relevant project development experience that the transmission developer believes may demonstrate its expertise in the above areas.

3. Identification of Transmission Developers Satisfying the Criteria

a. Notification to Transmission Developer

No later than September 30 each year, the PMC is to notify each transmission developer whether it has satisfied the stated criteria.A

transmission developer failing to satisfy one or more of the qualification criteria is to be informed of the failure(s) and accorded an additional opportunity to cure any deficiency (ies) within thirty (30) calendar days of notice from the PMC by providing any additional information.

The PMC is to inform the transmission developer whether the additional information satisfies the qualification criteria within forty-five (45) calendar days of receipt of the additional information.

The PMC is to identify the transmission developers that have satisfied the qualification criteria (the “Eligible Transmission Developers”) by posting on the WestConnect website, on or before December 31 of each year.

b. Annual Recertification Process and Reporting Requirements

By June 30 of each year, each Eligible Transmission Developer must submit to WestConnect a notarized letter signed by an authorized officer of the Eligible Transmission Developer certifying that the Eligible Transmission Developer continues to meet the current qualification criteria.

The Eligible Transmission Developer shall submit to the PMC an annual certification fee equal to the amount of the WestConnect annual membership fee. If the Eligible Transmission Developer is a member of WestConnect and is current in payment of its annual membership fee, then no certification fee will be required.

If at any time there is a change to the information provided in its application, an Eligible Transmission Developer shall be required to inform the PMC chair within thirty (30) calendar days of such change so that the PMC may determine whether the Eligible Transmission Developer continues to satisfy the qualification criteria. Upon notification of any such change, the PMC shall have the option to: (1) determine that the change does not affect the status of the transmission developer as an Eligible Transmission Developer; (2) suspend the transmission developer’s eligibility status until any deficiency in the transmission developer’s qualifications is cured; (3) allow the transmission developer to maintain its eligibility status for a limited time period, as specified by the PMC, while the transmission developer cures the deficiency; or (4) terminate the transmission developer’s eligibility status.

c. Termination of Eligibility Status

The PMC may terminate an Eligible Transmission Developer’s status if the Eligible Transmission Developer: (1) fails to submit its

annual certification letter; (2) fails to pay the applicable WestConnect membership fees; (3) experiences a change in its qualifications and the PMC determines that it may no longer qualify as an Eligible Transmission Developer; (4) informs the PMC that it no longer desires to be an Eligible Transmission Developer; (5) fails to notify the PMC of a change to the information provided in its application within thirty (30) days of such change; or (6) fails to execute the Planning Participation Agreement as agreed to in the qualification criteria within a reasonable time defined by the PMC, after seeking to be an entity eligible to use the regional cost allocation method for a transmission project selected in the Regional Plan for purposes of cost allocation.

E. Regional Planning Methodology and Protocols; Evaluation and Selection of Solution Alternatives

1. Overview of Regional Planning Methodology and Evaluation Process.

The Regional Planning Process is intended to identify regional needs and the most efficient or cost-effective solutions to satisfy those needs. Consistent with Order No. 890, qualified projects timely submitted through the Regional Planning Process will be evaluated and selected from competing solutions and resources such that all types of resources, as described below, are considered on a comparable basis. The same criteria and evaluation process will be applied to competing solutions and/or projects, regardless of type or class of stakeholder proposing them. Where a regional transmission need is identified, the PMC is to perform studies that seek to meet that need through regional projects, even in the absence of project proposals advanced by stakeholders or projects identified through the WECC process. When the PMC performs a study to meet an identified regional need in circumstances where no stakeholder has submitted a project proposal to meet that regional need, the PMC is to pursue such studies in a not unduly discriminatory fashion. The study methods employed for PMC-initiated studies will be the same types of study methods employed for stakeholder-initiated studies (*see, e.g.,* Section III.E.2 addressing the use of NERC Transmission Planning (TPL) Reliability Standards for regional reliability projects, Section III.E.3 addressing the use of production cost modeling for regional economic projects, and Section III.E.4 addressing the identification of Public Policy Requirements for regional public policy driven projects).

The solution alternatives will be evaluated against one another on the basis of the following criteria to select the preferred solution or combination of solutions: (1) ability to fulfill the identified need practically; (2) ability to meet applicable reliability criteria or NERC Transmission Planning Standards issues; (3) technical, operational and financial feasibility; (4) operational benefits/constraints or issues; (5) cost-effectiveness over the

time frame of the study or the life of the facilities, as appropriate (including adjustments, as necessary, for operational benefits/constraints or issues, including dependability); (6) where applicable, consistency with Public Policy Requirements, or regulatory requirements, including cost recovery through regulated rates; and (7) a project must be determined by the PMC to be a more efficient or cost-effective solution to one or more regional transmission needs to be eligible for regional cost allocation, as more particularly described below.

The Regional Planning Process provides for an assessment of regional solutions falling in one or more of the following categories:

- Regional reliability solutions.
- Regional economic solutions
- Regional transmission needs driven by Public Policy Requirements.
- Non-transmission alternatives

Black Hills encourages all interested stakeholders to consult the Business Practice Manual for additional details regarding the planning process, timing, and implementation mechanics. A flow chart depicting the Regional Planning Process is attached hereto as Exhibit 1.

All WestConnect Transmission Owners with Load Serving Obligations shall be responsible for submitting their local transmission plans for inclusion in the Regional Plan in accordance with the timeline stated in the Business Practice Manual. Those individual plans will be included in the Regional Plan base case system models.

2. WestConnect Reliability Planning Process

Once the base case is established and verified, the PMC is to perform a regional reliability assessment in which the base case system models will then be checked for adherence to the relevant NERC or WECC Transmission Planning Reliability Standards, through appropriate studies, including, but not limited to, steady-state power flow, voltage, stability, short circuit, and transient studies as more specifically outlined in the Business Practice Manual. If a reliability violation is identified in this power flow process, the violation will be referred back the appropriate transmission owner.

The PMC will identify projects to resolve any regional violations that impact more than one transmission owner of the relevant NERC or WECC Transmission Planning Standards or WECC criteria. In addition, as part of

the Regional Planning Process, an opportunity will be afforded to any interested party to propose regional reliability projects that are more efficient or cost-effective than other proposed solutions. The PMC will then identify the more efficient or cost-effective regional transmission project that meets the identified regional transmission need, taking into account factors such as how long the project would take to complete and the timing of the need. Because local transmission owners are ultimately responsible for compliance with NERC Reliability Standards and for meeting local needs, the local transmission plans will not be modified; however, the PMC may identify more efficient or cost-effective regional transmission projects. As seen in Exhibit 1 of this Attachment K, the PMC will perform the regional reliability assessment and, if necessary, identify a regional need for transmission projects to resolve any violations that impact more than one transmission owner in the fourth quarter of the planning cycle.

3. WestConnect Economic Planning Process

As part of the Regional Planning Process, the PMC is to analyze whether there are projects that have the potential to reduce the total delivered cost of energy by alleviating congestion or providing other economic benefits to the transmission system located within the WestConnect Planning Region through production cost modeling. This analysis also shall utilize WECC Board-approved recommendations to further investigate congestion within the WestConnect Planning Region for congestion relief or economic benefits that have subsequently been validated by WestConnect. Additional projects may also be proposed by WestConnect Stakeholders or developed through the stakeholder process for evaluation of economic benefits. Under the Regional Planning Process, the PMC will identify more efficient or cost-effective regional transmission projects, but will not modify local transmission plans.

The WestConnect economic planning process will analyze benefits via detailed production cost simulations. The models employed in the production cost simulations will appropriately consider the impact of transmission projects on production cost and system congestion. The WestConnect economic planning process will also consider the value of decreased reserve sharing requirements in the development of a Regional Plan that is more efficient or cost-effective. As seen in Exhibit 1 of this Attachment K, the PMC will develop the production cost modeling analysis in the second (2nd) and third (3rd) quarters of the planning cycle and identify economic transmission projects in the sixth (6th) quarter and parts of the fifth (5th) and seventh (7th) quarters of the planning cycle.

4. WestConnect Public Policy Planning Process

a. Procedures for Identifying Regional Transmission Needs Driven by

Public Policy Requirements

It is anticipated that any regional transmission need that is driven by Public Policy Requirements will be addressed initially within the local planning cycles of the individual transmission owners in the WestConnect Planning Region (through the consideration of local transmission needs driven by a Public Policy Requirement, since a Public Policy Requirement is a requirement that is imposed upon individual transmission owners (as opposed to a requirement that is imposed on a geographic region)). For those Public Policy Requirements that affect more than one transmission owner in the WestConnect Planning Region, a solution identified at the local level to satisfy the local needs of the affected transmission owner(s), may also satisfy a regional transmission need identified by the PMC for the WestConnect Planning Region.

WestConnect transmission owner members that are planning consistent with Order No. 890 will continue to conduct local transmission planning processes (Section II of this Attachment K), which provide a forum for discussions on local transmission needs driven by Public Policy Requirements. These local processes provide the basis for the individual transmission owners' local transmission plans, which are then incorporated into the regional base case at the start of the Regional Planning Process under Order No. 1000.

The PMC is to provide notice on the WestConnect website of both regional transmission planning meetings convened by the PMC for the WestConnect region, and local transmission planning meetings of the individual transmission owners in the WestConnect region.

The PMC will begin the evaluation of regional transmission needs driven by Public Policy Requirements by identifying any Public Policy Requirements that are driving local transmission needs of the transmission owners in the WestConnect Planning Region, and including them in the transmission system models (the regional base case) underlying the development of the Regional Plan. Then, the PMC will seek the input of stakeholders in the WestConnect region on those Public Policy Requirements in an effort to engage stakeholders in the process of identifying regional transmission needs driven by Public Policy Requirements. The PMC will communicate with stakeholders through public postings on the WestConnect website of meeting announcements and discussion forums. In addition, the PMC is to establish an email distribution list for those stakeholders who indicate a desire to receive information via electronic list serves.

After allowing for stakeholder input on regional transmission needs driven by Public Policy Requirements and regional solutions to those needs, as part of the Regional Planning Process, the PMC is to identify in the Regional Plan those regional transmission needs driven by Public Policy Requirements that were selected by the PMC for evaluation of regional solutions.

In selecting those regional transmission needs driven by Public Policy Requirements that will be evaluated for regional solutions in the current planning cycle, the PMC is to consider, on a non-discriminatory basis, factors, including but not limited to, the following:

- (i) whether the Public Policy Requirement is driving a regional transmission need that can be reasonably identified in the current planning cycle;
- (ii) the feasibility of addressing the regional transmission need driven by the Public Policy Requirement in the current planning cycle;
- (iii) the factual basis supporting the regional transmission need driven by the Public Policy Requirement; and
- (iv) whether a Public Policy Requirement has been identified for which a regional transmission need has not yet materialized, or for which there may exist a regional transmission need but the development of a solution to that need is premature.

No single factor shall necessarily be determinative in selecting among the potential regional transmission needs driven by Public Policy Requirements.

The process by which the PMC is to identify those regional transmission needs for which a regional transmission solution(s) will be evaluated, out of what may be a larger set of regional transmission needs, is to utilize the communication channels it has in place with stakeholders, identified above (open meetings and discussion forums convened by the PMC), through which regional transmission needs driven by Public Policy Requirements are to be part of the open dialogue.

b. Procedures for Identifying Solutions to Regional Transmission Needs Driven by Public Policy Requirements

Stakeholders are to have opportunities to participate in discussions during the Regional Planning Process with respect to the development of solutions to regional transmission needs driven by

Public Policy Requirements. Such participation may take the form of attending planning meetings, offering comments for consideration by the PMC on solutions to regional needs driven by Public Policy Requirements, and offering comments on proposals made by other stakeholders or by the PMC. Stakeholders that are members of the WestConnect PMC are performing the function of regional transmission planning, and, developing regional solutions to identified regional transmission needs driven by Public Policy Requirements through membership on subcommittees of the PMC.

After allowing for stakeholder input on solutions to regional transmission needs driven by Public Policy Requirements, as part of the Regional Planning Process, the PMC is to identify in the Regional Plan those regional transmission solutions driven by Public Policy Requirements that were selected by the PMC and any regional transmission project(s) that more efficiently or cost-effectively meet those needs.

The procedures for identifying and evaluating potential solutions to the identified regional transmission needs driven by Public Policy Requirements are the same as those procedures used to evaluate any other project proposed in the Regional Planning Process, whether or not submitted for purposes of cost allocation.

The PMC will perform a Public Policy Requirements analysis to help identify if a transmission solution is necessary to meet an enacted public policy. For a transmission need driven by Public Policy requirements, the PMC will identify if a more efficient or cost effective regional transmission solution exists based upon several different considerations, including consideration of whether the project is necessary and capable of meeting transmission needs driven by Public Policy Requirements, while also:

- (i) Efficiently resolving any criteria violations identified by studies pursuant to any relevant NERC Transmission Planning (TPL) Reliability Standards for regional reliability projects or WECC Transmission Planning Reliability Standards or WECC criteria, as applicable, that could impact more than one Transmission Owner as a result of a Public Policy requirement or,
- (ii) Producing economic benefits shown through detailed production cost simulations. The models employed in the production cost simulations will appropriately consider the impact of transmission projects on production cost, system congestion and the value of decreased reserve sharing requirements.

The PMC will develop the public policy analysis in the sixth (6th) quarter and parts of the fifth (5th) and seventh (7th) quarters of the planning cycle.

c. Proposed Public Policy

A public policy that is proposed, but not required (because it is not yet enacted or promulgated by the applicable governmental authority) may be considered through Section III.E.3 (WestConnect Economic Planning Process) of this Attachment K, if time and resources permit.

d. Posting of Public Policy Considerations

WestConnect will maintain on its website (i) a list of all regional transmission needs identified that are driven by Public Policy Requirements and that are included in the studies for the current regional transmission planning cycle; and (ii) an explanation of why other suggested regional transmission needs driven by Public Policy Requirements will not be evaluated.

5. WestConnect Non-transmission Alternatives Planning Process

Non-transmission alternatives will be evaluated to determine if they will provide a more efficient or cost-effective solution to an identified regional transmission need. Non-transmission alternatives include, without limitation, technologies that defer or possibly eliminate the need for new and/or upgraded transmission lines, such as distributed generation resources, demand side management (load management, such as energy efficiency and demand response programs), energy storage facilities and smart grid equipment that can help eliminate or mitigate a grid reliability problem, reduce uneconomic grid congestion, and/or help to meet grid needs driven by Public Policy Requirements. Non-transmission alternatives are not eligible for regional cost allocation.

6. Approval of the WestConnect Regional Transmission Plan

The Cost Allocation Subcommittee is to submit, for review and comment, the results of its project benefit/cost analysis and beneficiary determination to the PMC Chair and to the identified beneficiaries of the transmission projects proposed for cost allocation. The PMC shall make available to its Members sufficient information to allow for a reasonable opportunity to comment on the proposed selection. The PMC shall not make a determination on the project benefit/cost analysis and beneficiary determination until it has reviewed all comments. Upon approval of the PMC, the project benefit/cost analysis and beneficiary identifications shall be posted by the PMC on the WestConnect website.

a. CTO Acceptance of Cost Allocation

Each CTO beneficiary will indicate whether it accepts the cost allocation for the project as follows:

- (i) A CTO Member, in its sole discretion, may elect to accept a cost allocation for each separate transmission facility for which it is identified as a beneficiary, but only if it notifies the Chair of the PMC in writing of its decision to accept any such cost allocation within sixty (60) calendar days after the benefit/cost analysis is posted by the PMC under this Section III.E.6; provided, however, that the PMC has the discretion to extend the 60-day period when additional time is necessary for an identified beneficiary to complete its internal review and deliberation process before deciding to accept the cost allocation.
- (ii) A CTO Member giving notice that it elects to accept a cost allocation for a transmission facility may rescind that notice at any time prior to the end of the sixty (60) day period, or such extended period established in this Section III.E.6.a.i.
- (iii) A CTO Member that does not accept a cost allocation for a transmission facility will not be subject to cost allocation for that transmission facility.

The information made available under this Section III.E.6 will be electronically masked and made available pursuant to a process that the PMC reasonably determines is necessary to prevent the disclosure of confidential information or CEII contained in the information.

b. Recalculation of Benefits and Costs for Reliability Projects

The Cost Allocation Subcommittee will adjust, as necessary, its project benefit/cost analysis and beneficiary identification for any transmission project that continues to meet the region's criteria for regional cost allocation. For any CTO beneficiary that does not accept cost allocation for a project under this Section 6, such CTO's transmission need(s) which was included within the identification of the region's transmission needs under Sections 1-4 (for which the regional project would have avoided an alternative reliability project in such CTO's local transmission plan) will be removed as a regional transmission need for purposes of justifying a project's approval as a project eligible for inclusion in the regional plan for purposes of cost allocation.

c. Recalculation of Benefits and Costs for Public Policy Requirements

Projects

The Cost Allocation Subcommittee will adjust, as necessary, its project benefit/cost analysis and beneficiary identification for any transmission project that continues to meet the region's criteria for regional cost allocation. For any CTO beneficiary that does not accept cost allocation for a project under this Section 6, such CTO's transmission need(s) which was included within the identification of the region's transmission needs under Sections 1-4 (for which the regional project would have avoided an alternative Public Policy Requirements project in such CTO's local transmission plan) will be removed as a regional transmission need for purposes of justifying a project's approval as a project eligible for inclusion in the Regional Plan for purposes of cost allocation. This shall include any such CTO's resource needs necessary to comply with Public Policy Requirements.

d. Recalculation of Benefits and Costs for Economic Projects

The Cost Allocation Subcommittee will adjust, as necessary, its project benefit/cost analysis and beneficiary identification for any transmission project that continues to meet the region's criteria for regional cost allocation. For any CTO beneficiary that does not accept cost allocation for a project under this Section 6, such CTO's transmission benefits which were included within the identification of the regional project's economic benefits under Sections 1-4 will be removed as a regional transmission benefit for purposes of justifying a project's approval as a project eligible for inclusion in the Regional Plan for purposes of cost allocation. This shall include the value of any economic benefits determined through the regional transmission plan to accrue to such CTO.

e. Resultant Increase in Beneficiary Cost Allocation

Any regional transmission project that continues to meet the region's benefit/cost and other criteria for regional cost allocation will remain eligible for selection in the Regional Plan for purposes of cost allocation.

f. Approval of the WestConnect Regional Transmission Plan

Upon completion of the process outlined above, the PMC will vote on whether to accept the proposed plan. The Regional Transmission Plan will document why projects were either included or not included in the Regional Transmission Plan. In addition, the Regional Plan is to describe the manner in which the applicable regional cost allocation methodology was applied to each project selected in the Regional Plan for purposes of regional cost allocation. Projects that meet system needs are incorporated into the Regional Plan. Participant funded projects and other types of projects may be included in the Regional Plan; however, those projects are not eligible

for regional cost allocation.

7. Reevaluation of the WestConnect Regional Transmission Plan

The PMC is the governing body responsible for deciding whether to reevaluate the Regional Plan to determine if the conditions, facts and/or circumstances relied upon in initially selecting a transmission project for inclusion in the Regional Plan for purposes of cost allocation have changed and, as a result, require reevaluation. Reevaluation will begin within the second planning cycle following the Effective Date. The Regional Plan and any project selected for cost allocation in the Regional Plan, including any local or single-system transmission projects or planned transmission system upgrades to existing facilities selected for purposes of cost allocation, shall be subject to reevaluation in each subsequent planning cycle according to the criteria below. Upon reevaluation, the Regional Plan and any projects selected for purposes of cost allocation in connection therewith may be subject to modification, including the status as a project selected for cost allocation, with any costs reallocated under Section VII as if it were a new project. Only the PMC has the authority to modify the status of a transmission project selected for cost allocation. Conditions that trigger reevaluation are:

- The underlying project characteristics and/or regional or interregional needs change in the Regional Plan. Examples include, but are not limited to: (a) a project's failure to secure a developer, or a developer's failure to maintain the qualifications necessary to utilize regional cost allocation, or (b) a change (increase or decrease) in the identified beneficiaries of a project (which changes may occur through company acquisitions, dissolutions or otherwise), (c) a change in the status of a large load that contributes to the need for a project, or (d) projects affected by a change in law or regulation;
- Projects that are delayed and fail to meet their submitted in-service date by more than two (2) years. This includes projects delayed by funding, regulatory approval, contractual administration, legal proceedings (including arbitration), construction delays, or other delays;
- Projects with significant project changes, including, but not limited to kilovolt (kV), megavolt ampere (MVA), or path rating, number of circuits, number of transmission elements, or interconnection locations; and
- Projects with a change in the calculation of benefits or benefit/cost (B/C) ratio that may affect whether the project selected for inclusion in the Regional Plan for purposes of cost allocation is a more efficient or cost-effective regional solution.

- Example 1: Where an increase in the selected project's costs, including but not limited to, material, labor, environmental mitigation, land acquisition, operations and maintenance, and mitigation for identified transmission system and region, causes the total project costs to increase above the level upon which the project was initially selected for inclusion in the Regional Plan for purposes of cost allocation, the inclusion of the regional project in the Regional Plan will be reevaluated to determine if the regional project continues to satisfy the region's B/C ratio and can be found to be a more efficient or cost-effective solution under current cost information.
- Example 2: A selected project's benefits may include identification of a reliability benefit in the form of remedying a violation of a Reliability Standard. If the identified beneficiary implements improvements, such as a Remedial Action Scheme, to achieve reliability in compliance with the Reliability Standard at issue, inclusion of the regional project in the regional plan will be reevaluated to determine if the regional project continues to satisfy the region's B/C ratio and can be found to be a more efficient or cost-effective solution under current benefit information.
- Example 3: Where a project's estimated benefits include benefits in the form of avoided costs (e.g., a regional project's ability to avoid a local project), and the project is not avoided, the inclusion of the regional project in the Regional Plan will be reevaluated to determine if the regional project continues to satisfy the region's B/C ratio and can be found to be a more efficient or cost-effective solution under current facts and circumstances.

Projects selected for purposes of cost allocation will continue to be reevaluated until all the following conditions have been met.

- State and federal approval processes completed and approved (including cost recovery approval under Section 205 of the Federal Power Act as applicable);
- All local, state and federal siting permits have been approved; and
- Major construction contracts have been issued.

When the Regional Plan is reevaluated as a result of any of the conditions triggering reevaluation addressed above, the PMC is to determine if an evaluation of alternative transmission solutions is needed in order to meet an identified regional need. In doing so, the PMC is to use the same processes and procedures it used in the identification of the original transmission solution to the regional need. If an

alternative transmission solution is needed, the incumbent transmission owner may propose one or more solutions that it would implement within its retail distribution service territory or footprint, and if such proposed solution is a transmission facility, the transmission owner may submit the project for possible selection in the Regional Plan for purposes of cost allocation.

Projects not subject to reevaluation include, but are not limited to, the following:

- Local or single system transmission projects that have been identified in individual Transmission Owner's Transmission Planning (TPL) Reliability Standards compliance assessments to mitigate reliability issues and that have not been proposed for (and selected by the PMC for) regional cost allocation; and
- Planned transmission system upgrades to existing facilities that have not been proposed for (and selected by the PMC for) regional cost allocation.

Projects meeting any of the following criteria as of the Effective Date will also not be subject to reevaluation under the Regional Planning Process:

- Projects of transmission owners who have signed the Planning Participation Agreement and that have received approval through local or state regulatory authorities or board approval;
- Local or single system transmission projects that have been planned and submitted for inclusion in the Regional Plan or exist in the 10-year corporate capital project budgets; and
- Projects that are undergoing review through the WECC Project Coordination and Rating Review Process as of the last Effective Date.

8. Confidential or Proprietary Information

Although the Regional Planning Process is open to all stakeholders, stakeholders will be required to comply at all times with certain applicable confidentiality measures necessary to protect confidential information, proprietary information or CEII. From time to time the regional transmission planning studies and/or open stakeholder meetings may include access to base case data that are WECC proprietary data, information classified as CEII by FERC, or other similar confidential or proprietary information. In such cases, access to such confidential or proprietary information shall be limited to only those stakeholders that (i) hold membership in or execute a non-disclosure agreement (NDA) with WECC (see Black Hills Attachment K List of Hyperlinks http://www.oatioasis.com/BHCT/BHCTdocs/BHCT_Hyperlinks_List.pdf)

; (ii) execute a non-disclosure agreement with the applicable WestConnect Planning Region members; or (iii) are parties to the Planning Participation Agreement, as may be applicable.

Any entity wishing to access confidential information, subject to applicable standards of conduct requirements, discussed in the Regional Planning Process must execute an NDA, and submit it to NDA@westconnect.com <<mailto:NDA@westconnect.com>>. A link to the NDA has been provided (*see* Transmission Provider Attachment K List of Hyperlinks <http://www.oatioasis.com/bhct/>).

IV. Recovery of Planning Costs

Unless Black Hills allocates planning-related costs to an individual Stakeholder as permitted under the OATT, all costs incurred by Black Hills related to the LTP process, or as part of sub-regional or regional planning process, will be included in Black Hills' transmission rate base, as applicable.

V. Dispute Resolution

In the event of a dispute concerning either a procedural or substantive matter within the jurisdiction of FERC, the following dispute resolution processes will apply:

- A. WECC. If the dispute is one that is within the scope of the WECC dispute resolution procedures, then such procedures contained in the WECC Business and Governance Guidelines and Policies will apply. (See Black Hills Attachment K Hyperlinks List posted on the PSCo OASIS <http://www.oatioasis.com/bhct/>).
- B. Non-WECC disputes. For disputes not within the scope of the WECC dispute resolution procedures and for disputes not between or among the members of the Planning Management Committee (which disputes will be subject to separate dispute resolution provisions set forth in the Planning Participation Agreement), the dispute resolution procedures set forth in Section 12 of Black Hills' OATT, as applicable, will apply, with the added provision that upon agreement of the parties, any dispute that is not resolved by direct negotiation between or among the affected parties within a reasonable period of time, may be referred to mediation (before or during arbitration), and all applicable timelines will be suspended until such time as the mediation process terminates (unless otherwise agreed by the parties). Notwithstanding that the dispute resolution procedures under Section 12 of Black Hills' OATT apply only to Black Hills and its respective Transmission Customers, Section 12 of Black Hills OATT will be deemed to be applicable to stakeholders for purposes of this Attachment K, except as otherwise provided herein.
- C. Notwithstanding anything to the contrary in this Section V, any affected party may refer the matter to FERC for resolution, for example, by filing with FERC a complaint, a request for declaratory order or a change in rate.

For disputes between members of the PMC, the following dispute resolution procedures are to

apply:

- A. The disputing PMC member(s) initiates its dispute by providing written notification to the PMC (or a designated sub-committee of the PMC) in accordance with the provisions of the Planning Participation Agreement, in which event the PMC will seek to resolve the dispute through discussion, negotiation and the development of a recommended course of action. The PMC may act to adopt a resolution recommended by its own committee members or sub-committees, or alternatively the disputing parties may act to refer the dispute to arbitration for resolution.
- B. A dispute may be referred to arbitration under the governing provisions of the Planning Participation Agreement.
- C. The availability of the dispute resolution avenues identified above does not eliminate a disputing PMC member's(s') right under the Federal Power Act to refer either a procedural or substantive matter within the jurisdiction of FERC to FERC for resolution, for example by filing with FERC a complaint, a request for declaratory order or a change in rate.

VI. Coordination at the Western Interconnection Level

Black Hills will coordinate its plan on a west-wide regional basis through WestConnect. WestConnect will coordinate its Regional Plan with TEPPC.

- A. Procedures Regional Planning Project Review
 1. WECC Coordination of Reliability Planning.
 - a. WECC develops the Western Interconnection wide base cases for transmission planning analysis such as power flow, stability, and dynamic voltage stability studies. The WECC approved base cases are used for study purposes by transmission planners, subregional transmission planning groups, and other entities that have signed non-disclosure agreements with WECC.
 - b. WECC also maintains a database for reporting the status of all planned projects throughout the Western Interconnection.
 - c. WECC provides for coordination of planned projects through its Procedures for Regional Planning project review.
 - d. WECC's path rating process ensures that a new project will have no adverse effect on existing projects or facilities.
 2. WECC-TEPPC Open Stakeholder Meetings. Western Interconnection wide economic planning studies are conducted by the WECC-TEPPC in an open stakeholder process that holds region-wide stakeholder meetings on a regular basis. The WECC-TEPPC Transmission Planning Protocol,

including the TEPPC procedures for prioritizing and completing regional economic studies, is posted on the WECC website (see Hyperlinks List on Black Hills' OASIS at <http://www.oatioasis.com/bhct/> . Black Hills participates in region-wide planning through the WestConnect Planning Region, as appropriate, to ensure data and assumptions are coordinated.

3. Role of WECC-TEPPC: WECC-TEPPC provides two main functions in relation to Black Hills planning process.
 - a. Development and maintenance of the west-wide economic planning study database.
 - (i) TEPPC uses publicly available data to compile a database that can be used by a number of economic congestion study tools.
 - (ii) TEPPC's database is publicly available for use in running economic congestion studies. For an interested transmission customer or stakeholder to utilize WECC's Pro-Mod planning model, such transmission customer or stakeholder must comply with the WECC confidentiality requirements.
 - b. Performance of Economic Planning Studies. TEPPC has a biennial study cycle, described in the WECC-TEPPC Transmission Planning Protocol (see Hyperlinks List on Black Hills' OASIS at <http://www.oatioasis.com/bhct/> during which it will update databases, develop and approve a study plan that includes studying Requester's high priority economic study requests as determined by the open TEPPC stakeholder process, perform the approved studies and document the results in a report.
 - c. Identification of Congested Paths for WestConnect Economic Review. Through TEPPC's economic study process, congested paths may be reviewed and identified as being candidates for economic transmission studies. Upon WECC Board approval of a designation for such a path, the Regional Planning Process will review the path for potential economic transmission solutions.

VII. Cost Allocation and New Projects

A. Local Transmission Projects

Local Transmission Projects are projects located within a Transmission Owner's retail distribution service territory or footprint unless such projects are submitted and selected in the Regional Plan for purposes of cost allocation.⁵ A

5. The reference to a transmission owner's "footprint" refers to the electrical footprint of the transmission owner (i.e., the location of that transmission owner's electrical assets) and not necessarily the physical/spatial footprint.

Where a transmission owner within the WestConnect Planning Region is a transmission-only company with no retail distribution service territory, the term, footprint, would refer to the location of the transmission facilities of such transmission-only company.

Transmission Owner is not precluded from proposing Local Transmission Projects for inclusion in the Regional Plan for purposes of cost allocation in the Regional Planning Process. A Local Transmission Project that is not submitted or not selected for inclusion in the Regional Plan is not eligible for cost allocation in the Regional Plan, and not subject to the provisions governing regional cost allocation set forth below.

For any transmission project where Black Hills is the sole owner or such project is to be built within or for the benefit of the existing Black Hills system such as local, small and/or reliability transmission projects, Black Hills shall proceed with the project pursuant to its rights and obligations as a transmission provider for the local area. Any projects necessary to ensure reliability or that provide economic benefits to the Black Hills system and which fall outside the requirements for inclusion in the Regional Plan for purposes of cost allocation are eligible to be considered Local Transmission Projects.

Black Hills may share ownership, and associated costs, of any new transmission project, based upon mutual agreement between the parties. Such a joint ownership arrangement may arise because of existing joint ownership of facilities in the area of the new facilities, overlapping service territories, or other relevant considerations.

Black Hills will utilize a case-by-case approach to allocate costs for new Local Transmission Projects. This approach will be based on the following principles:

1. Open Season Solicitation of Interest: For any project identified in a Black Hills planning study (for reliability and/or economic projects) in which Black Hills is the project sponsor, Black Hills may elect to provide an “open season” solicitation of interest to secure additional project participants. Upon a determination by Black Hills to hold an open season solicitation of interest for a project, Black Hills will:
 - a. Announce and solicit interest in the project through informational meetings, its website and/or other means of dissemination as appropriate.
 - b. Hold meetings with interested parties and meetings with public utility staffs from potentially affected states.
 - c. Post information via Black Hills’ OASIS website.
 - d. Develop the initial project specifications, the initial cost estimates and potential transmission line routes; guide negotiations and assist interested parties to determine cost responsibility for initial studies;

guide the project through the applicable line siting processes; develop final project specifications and costs; obtain commitments from participants for final project cost shares; and secure execution of construction and operating agreements.

2. Black Hills Coordination within a Solicitation of Interest Process: Black Hills, whether as a project sponsor or a participant will coordinate as necessary with any other participant or sponsor, as the case may be.
3. Black Hills Projects without a Solicitation of Interest: Black Hills may elect to proceed with small and/or reliability projects without an open season solicitation of interest, in which case Black Hills will proceed with the project pursuant to its rights and obligations as a Black Hills.
4. Allocation of Costs:
 - a. Proportional Allocation: For any project entered into where an open season solicitation process has been used, project costs and associated transmission rights would generally be allocated proportionally to project participants subject to approval of the participation agreement by FERC. In the event the open season process results in a single participant, the full cost and transmission rights will be allocated to that participant.
 - b. Economic Benefits or Congestion Relief: For a project wholly on Black Hills' system that is undertaken for economic reasons or congestion relief at the request of a Requestor, the project costs will be allocated to the Requestor.
 - c. Black Hills Rate Recovery: Notwithstanding the foregoing provisions, Black Hills will not assume cost responsibility for any project if the cost of the project is not reasonably expected to be recoverable in its retail and/or wholesale rates.

B. Regional Transmission Projects.

For any project determined by the PMC to be eligible for regional cost allocation, project costs shall be allocated pursuant to the processes set forth in Sections III through VII of this Attachment K.

The PMC, with input from the CAS, is to determine whether a project is eligible for regional cost allocation, and assesses the project's costs against its benefits in accordance with the following factors:

- Benefits and beneficiaries will be identified before cost allocation methods are applied.
- Cost assignments will be commensurate with estimated benefits.

- Those that receive no benefits will not be involuntarily assigned costs.
- A benefit-to-cost threshold (B/C) of not more than 1.25 will be used, as applicable, so that projects with significant benefits are not excluded.
- Costs must be allocated solely within the WestConnect Planning Region, unless other regions or entities voluntarily assumes costs.
- Costs for upgrades on neighboring transmission systems or other planning regions that are (i) required to be mitigated by the WECC Path Rating process, FERC tariff requirements, or NERC Reliability Standards, or (ii) negotiated among interconnected parties will be included in the total project costs and used in the calculation of B/C ratios.
- Cost allocation method and data will be transparent and with adequate documentation.
- Different cost allocation methods may be used for different types of projects.

Specifically, the PMC will consider the following projects eligible for cost allocation consideration as further described below based on specified criteria:

- Reliability Projects;
- Economic or Congestion Relief Projects; or
- Public Policy Projects.

Only projects that fall within one or more of these three categories and satisfy the cost-to-benefit analyses and other requirements, as specified herein, are eligible for cost allocation in the WestConnect Planning Region. Black Hills encourages all interested stakeholders to consult the Business Practice Manual for additional details regarding the assessment for eligibility for regional cost allocation. Summary provisions are provided below:⁶

1. Allocation of Costs for Reliability Projects

In order to allocate costs to transmission owners for system reliability improvements that are necessary for their systems to meet the NERC Transmission Planning Standards, the WestConnect cost allocation procedure will allocate costs for system reliability improvements only when a system improvement is required to comply with the NERC Transmission Planning Standards during the planning horizon.

All components of a transmission owner's local transmission plan will be rolled up into the Regional Plan and will be considered local transmission

6. References to “transmission owners” in the cost allocation provisions are to transmission owners for whom the WestConnect Planning Management Committee is performing the function of regional transmission planning. At present, those transmission owners are TOLSO members.

projects that are not eligible for regional cost allocation. A system performance analysis will be performed on the collective plans to ensure the combined plans adhere to all relevant NERC Transmission Planning Standards, and stakeholders will be afforded an opportunity to propose projects that are more efficient or cost-effective than components of multiple transmission owner local plans as outlined in Section III.E, above.

Should a reliability issue be identified in the review of the included local transmission plan, the project necessary to address that reliability issue will be included in the Regional Plan and the cost will be shared by the utilities whose load contributed to the need for the project.

Should multiple utilities have separate reliability issues that are addressed more efficiently or cost-effectively by a single regional project, that regional project will be approved for selection in the Regional Plan and the cost will be shared by those transmission owners in proportion to the cost of alternatives that could be pursued by the individual transmission owners to resolve the reliability issue. The ultimate responsibility for maintaining system reliability and compliance with NERC Transmission Planning Standards rests with each transmission owner.

The costs for regional reliability projects will be allocated according to the following equation:

$$(1 \text{ divided by } 2) \text{ times } 3 \text{ equals } 4$$

Where:

1. is the cost of local reliability upgrades necessary to avoid construction of the regional reliability project in the relevant transmission owner’s retail distribution service territory or footprint
2. is the total cost of local reliability upgrades in the combination of transmission owners’ retail distribution service territories or footprints necessary to avoid construction of the regional reliability project
3. is the total cost of the regional reliability project
4. is the total cost allocated to the relevant transmission owner’s retail distribution service territory or footprint

The manner in which the PMC applied this methodology to allocate the costs of each regional reliability project shall be described in the Regional

Plan.

2. Allocation of Costs for Economic Projects

Cost allocation for economic projects associated with congestion relief that provide for more economic operation of the system will be based on the calculation of economic benefits that each transmission owner system will receive. Cost allocation for economic projects shall include scenario analyses to ensure that benefits will actually be received by beneficiaries with relative certainty. Projects for which benefits and beneficiaries are highly uncertain and vary beyond reasonable parameters based on assumptions about future conditions will not be selected for cost allocation.

In order for a project to be considered economically-justified and receive cost allocation associated with economic projects, the project must have a B/C ratio that is greater than 1.0 under each reasonable scenario evaluated and have an average ratio of at least 1.25 under all reasonable scenarios evaluated. Costs will be allocated on the basis of the average of all scenarios evaluated. The B/C ratio shall be calculated by the PMC. This B/C ratio will be determined by calculating the aggregate load-weighted benefit-to-cost ratio for each transmission system in the WestConnect Planning Region. The benefits methodology laid out below ensures that the entities that benefit the most from the completion of an economic project are allocated costs commensurate with those project benefits.

The cost of any project that has an aggregate 1.25 B/C ratio or greater will be divided among the transmission owners that show a benefit based on the amount of benefits calculated to each respective transmission owner. For example, if a \$100 million dollar project is shown to have \$150 million in economic benefit, the entities for which the economic benefit is incurred will be determined. The cost of the project will then be allocated to those entities, based on the extent of each entity's economic benefits relative to the total project benefits. This will ensure that each entity that is allocated cost has a B/C ratio equal to the total project B/C ratio. For example:

- Project with \$150 million in economic benefit and \$100 million in cost
 - Company 1 has \$90 million in benefits; Company 2 has \$60 million in benefits
 - Company 1 allocation: $90/150 (100) = \$60$ million
 - Company 1 B/C ratio: $90/60 = 1.5$
 - Company 2 allocation: $60/150 (100) = \$40$ million
 - Company 2 B/C ratio: $60/40 = 1.5$

Other than through the reevaluation process described in Section III.E.7 of this Attachment K, the benefits and costs used in the evaluation shall only be calculated during the planning period and shall be compared on a net present value basis.

The WestConnect economic planning process will consider production cost savings and reduction in reserve sharing requirements as economic benefits capable of contributing to the determination that a project is economically justified for cost allocation. Production cost savings are to be determined by the PMC performing a product cost simulation to model the impact of the transmission project on production costs and congestion. Production cost savings will be calculated as the reduction in production costs between a production cost simulation with the project included compared to a simulation without the project. Reductions in reserve sharing requirements are to be determined by the PMC identifying a transmission project's impact on the reserve requirements of individual transmission systems, and not on the basis of the project's collective impact on a reserve sharing group, as a whole. The production cost models are to appropriately consider the hurdle rates between transmission systems. The following production cost principles may be applied:

- The production cost savings from a project must be present in each year from the project in-service date and extending out at least ten (10) years.
- Cost savings must be expressed in present-value dollars and should consider the impact of various fuel cost forecasts.
- The production cost study must account for contracts and agreements related to the use of the transmission system (this refers to paths in systems that might be contractually limited but not reliability limited).
- The production cost study must account for contracts and agreements related to the access and use of generation (this refers to generators that might only use spot purchases for fuel rather than firm purchases, or generation that has been designated as network resources for some entities and thus cannot be accessed at will by non-owners).

Access by stakeholders to the PMC's application of its regional cost allocation method for a specific economic transmission project is available in several ways: First, stakeholders that are members of the PMC will have firsthand knowledge of the way in which the regional method was applied to a particular project because the PMC is responsible for performing the application of the regional cost allocation method. Second, stakeholders that choose not to become members of the PMC may access such

information through the WestConnect regional stakeholder process. See Section III.B of this Attachment K. Third, the manner in which the PMC applied this methodology to allocate the costs of each economic project shall be described in the Regional Plan.

In determining which entities will be allocated costs for economic projects, WestConnect will compare the economic value of benefits received by an entity with the cost of the project to ensure that each entity allocated cost receives a benefit/cost ratio equal to the aggregate load-weighted benefit-to-cost ratio. These costs allocated to each company will be calculated based on the following equation:

$$(1 \text{ divided by } 2) \text{ times } 3 \text{ equals } 4$$

Where:

1. is the total projected present value of economic benefits for the relevant transmission owner
2. is the total projected present value of economic benefits for the entire project
3. is the total cost for the economic project
4. is the total cost allocated to the relevant transmission owner

Any transmission owner with benefits less than or equal to one percent of total project benefits will be excluded from cost allocation. Where a project satisfies the B/C ratio, and is determined to provide benefits less than or equal to one percent of total project benefits to an identified transmission owner, such benefits will be re-allocated to all other identified beneficiaries on a pro rata basis, in relation to each entity's share of total project benefits.

3. Allocation of Costs for Public Policy Projects

Any transmission system additions that arise from Public Policy Requirements shall be included in the system models used for the WestConnect transmission system studies. Further, any additional system needs that arise from proposed public policy shall be reported by each entity for its own service territory. Decisions on the inclusion of those needs shall be made during the consideration and approval of the system models. Transmission needs driven by Public Policy Requirements will be included in the evaluation of reliability and economic projects.

Except for projects proposed through a transmission owner's local planning process, arising out of a local need for transmission infrastructure to satisfy Public Policy Requirements that are not submitted as proposed projects for cost allocation (which are addressed in Section II of this Attachment K), any projects arising out of a regional need for transmission infrastructure to

satisfy the Public Policy Requirements shall be considered public policy projects eligible for evaluation in the Regional Planning Process.

Stakeholders may participate in identifying regional transmission needs driven by Public Policy Requirements. After seeking the input of stakeholders pursuant to the stakeholder participation provisions of Section III, the PMC is to determine whether to move forward with the identification of a regional solution to a particular regional need driven by Public Policy Requirements. Stakeholders may participate in identifying a regional solution to a regional need driven by Public Policy Requirements pursuant to the stakeholder participation provisions of Section III, or through membership on the PMC itself. After seeking the input of stakeholders, the PMC is to determine whether to select a particular regional solution in the regional transmission plan for purposes of cost allocation. The identification of beneficiaries of these projects shall be the entities that will access the resources enabled by the project in order to meet their Public Policy Requirements.

If an entity accesses resources that were enabled by a prior public policy project, that entity will need to either share in its relative share of the costs of that public policy project or acquire sufficient transmission service rights to move the resources to its load with the determination left up to the entity or entities that were originally allocated the cost for the public policy project.

The costs for public policy projects will be allocated according to the following equation:

$$(1 \text{ divided by } 2) \text{ times } 3 \text{ equals } 4$$

Where:

- 1 is the number of megawatts of public policy resources enabled by the public policy project for the entity in question
- 2 is the total number of megawatts of public policy resources enabled by the public policy project
- 3 is the total project cost
- 4 is the cost for the public policy project allocated to the entity in question

The process to interconnect individual generation resources is provided for under the generator interconnection section of each utility's OATT and not under this process.

Requests for transmission service that originate in a member's system and terminate at the border shall be handled through that member's OATT. Regional transmission needs necessary to meet Public Policy Requirements will be addressed through the Public Policy Requirements section of the Regional Planning Process.

The manner in which WestConnect applied this methodology to each public policy project shall be described in the Regional Transmission Plan.

4. Combination of Benefits

In developing a more efficient or cost-effective plan, it is possible for the plan to jointly consider multiple types of benefits when approving projects for inclusion in the Regional Plan. The determination to consider multiple types of benefits for a particular project shall be made through the WestConnect stakeholder process, in which interested stakeholders are given an opportunity to provide input as set forth in Section III of this Attachment K. In determining whether a project would provide multiple benefits, the PMC is to categorize the benefits as (a) necessary to meet NERC Transmission Planning Reliability Standards (reliability); (b) achieving production cost savings or a reduction in reserve sharing requirements (economic); or (c) necessary to meet transmission needs driven by Public Policy Requirements, as applicable, using the methods set forth in this Attachment K. The PMC will identify all three categories of benefits in its regional cost allocation process. If a project cannot pass the cost allocation threshold for any one of the three benefit categories, alone (reliability, economic or public policy), the sum of benefits from each benefit category may be considered.

- With respect to a reliability-driven regional transmission project, the quantified benefits of the project to each identified beneficiary must be greater, by a margin of 1.25 or more to 1, than the result of the equation identified in Section B.1 above (where the result is shown as item 4 in the formula).
- With respect to an economic-driven regional transmission project, the quantified benefits of the project to each identified beneficiary must be greater than the project's cost to each beneficiary under each reasonable scenario evaluated, and must yield an average ratio of at least 1.25 to 1 under all reasonable scenarios evaluated, as described in Section B.2 above.
- With respect to a public policy requirements-driven regional transmission project, the quantified benefits of the project to each identified beneficiary must be greater, by a margin of 1.25 or more to 1, than the result of the equation identified in Section B.3 above (where the result is shown as item 4 in the formula).

If a single regional transmission project is determined to provide benefits in more than one category, but does not meet the cost threshold for any single category, the PMC may consider the sum of benefits from each benefit category to determine if the regional transmission project provides, in total, benefits per beneficiary that meet or exceed the region's 1.25 to 1 benefit to

cost ratio. To illustrate, consider the following example where a regional project developed to provide public policy requirement benefits might also provide for economic benefits to the same beneficiaries:

A regional project submittal has undergone analysis for its quantifiable benefits and costs and is determined to cost \$100 million and produce benefits to identified beneficiaries in two categories: economic benefits of \$101 million (on average, under all economic scenarios quantified), and public policy requirement benefits of \$70 million. The project is found to fail the cost threshold for each category, individually, but when the total benefits are combined and the project's total regional benefits per beneficiary are weighed against the project's total costs per beneficiary, the project can be found to meet or surpass the region's 1.25 to 1 benefit to cost ratio per beneficiary:

- The benefits to Beneficiary A of pursuing the regional solution (60% of the regional project's total \$171 million in benefits) = \$102.6 million. When \$102.6 million in project benefits is compared against \$60 million in project costs (60% of project costs), it yields a B/C ratio of 1.71 to 1 for Beneficiary A.
- The benefits to Beneficiary B of pursuing the regional solution (40% of the regional project's total \$171 million in benefits) = \$68.4 million. When \$68.4 million in project benefits is compared against \$40 million in project costs (40% of project costs), it yields a B/C ratio of 1.71 to 1 for Beneficiary B.

Even though the regional project does not pass the cost allocation threshold in any individual benefit category, the PMC may consider the sum of the project's benefits in all categories.

For those regional projects that satisfy the region's cost allocation threshold, the PMC then will continue its evaluation process by considering whether the regional project meets the region's identified reliability, economic and Public Policy Requirements-driven needs more efficiently or cost-effectively than solutions identified by individual transmission providers in their local transmission planning processes.

The costs for projects that rely upon multiple types of benefits to secure inclusion in the Regional Plan for purposes of cost allocation will be shared according to the amount of cost that is justified by each type of benefits.

5. Allocation of Ownership and Capacity Rights.

An Eligible Transmission Developer that is subject to the Commission's

jurisdiction under Section 205 of the Federal Power Act may not recover project costs from identified beneficiaries in the WestConnect Planning Region without securing approval for project cost recovery from FERC through a separate proceeding brought by the Eligible Transmission Developer under Section 205 of the Federal Power Act. In no event will identified beneficiaries in the WestConnect Planning Region from whom project costs are sought to be recovered under Section 205 be denied either transmission transfer capability or ownership rights proportionate to their allocated costs, as determined by FERC in such proceeding. An Eligible Transmission Developer that is not subject to the Commission's jurisdiction under Section 205 of the Federal Power Act may seek cost recovery from identified beneficiaries in the WestConnect Planning Region either (a) through bilateral agreements that are voluntarily entered into between such Eligible Transmission Developer and the applicable identified beneficiaries; or (b) by obtaining approval from FERC for project cost recovery pursuant to any other applicable section of the Federal Power Act.

If a project beneficiary receives transmission transfer capability on the project in exchange for transmission service payments, such project beneficiary may resell the transfer capability. Alternatively, a project beneficiary could seek to make a direct capital contribution to the project construction cost (in lieu of making transmission service payments) in which case, the project beneficiary would instead receive an ownership percentage in proportion to their capital contribution (Ownership Proposal). This Ownership Proposal does not create a right of first refusal for transmission beneficiaries.

An ownership alternative will only be pursued if the Eligible Transmission Developer agrees. The Eligible Transmission Developer and the beneficiaries will enter into contract negotiations to address the many details regarding the capital funding mechanics and timing, as well as other details, such as defining (as between the Eligible Transmission Developer, whether a nonincumbent or incumbent transmission developer, and those receiving ownership interests) responsibility for operations and maintenance, administrative tasks, compliance with governing laws and regulations, etc. These negotiations will take place at arm's length, without any one party having undue leverage over the other.

A transmission project beneficiary should not be expected to pay for its benefits from the project twice: once through a capital contribution, and again through transmission service payments. The Ownership Proposal permits an ownership share in a project that is in the same proportion to a beneficiary's allocable costs, which costs will have been allocated roughly commensurate with the benefits to be gained from the project. This will allow the beneficiary to earn a return on its investment. In addition, it allows those beneficiaries that may not necessarily benefit from additional transfer capability on a new transmission project, whether due to lack of

contiguity to the new facilities or otherwise, to realize the benefits through an ownership option.

Any transmission project participant that is identified as a beneficiary of the project might be permitted by the Eligible Transmission Developer to contribute capital (in lieu of transmission service payments) and receive a proportionate share of ownership rights in the transmission project. The Ownership Proposal affords an identified beneficiary who contributes toward the project costs the opportunity to obtain an ownership interest in lieu of an allocated share of the project costs through transmission service payments for transfer capability on the project; it does not, however, confer a right to invest capital in a project. The Ownership Proposal merely identifies that, to the extent it is agreed among the parties that capital may be contributed toward a transmission project's construction, a proportionate share of ownership rights will follow.

Nothing in this Attachment K with respect to Order No. 1000 cost allocation imposes any new service on beneficiaries. Similarly, nothing in this Attachment K with respect to Order No. 1000 cost allocation imposes on an Eligible Transmission Developer an obligation to become a provider of transmission services to identified beneficiaries simply as a result of a project's having been selected in the Regional Plan for purposes of cost allocation; provided, however, if that Eligible Transmission Developer seeks authorization to provide transmission services to beneficiaries or others, and to charge rates or otherwise recover costs from beneficiaries or others associated with any transmission services it were to propose, it must do so by contract and/or under separate proceedings under the Federal Power Act. The purpose of this Section VII.B.5 is to (a) provide an option to a project developer to negotiate ownership rights in the project with identified beneficiaries, if both the developer and the identified beneficiaries mutually desire to do so, and (b) specify that, although Order No. 1000 cost allocation does not impose any new service on beneficiaries, identified beneficiaries have the opportunity to discuss with the project developer the potential for entering into transmission service agreements for transmission capacity rights in the project, and (c) ensure that Order No. 1000 cost allocation does not mean that a project developer may recover project costs from identified beneficiaries without providing transmission transfer capability or ownership rights, and without securing approval for project cost recovery by contract and/or under a separate proceeding under the Federal Power Act.

If an Eligible Transmission Developer is not subject to FERC's jurisdiction under section 205 of the Federal Power Act, the Eligible Transmission Developer would have to seek to recover project costs from identified beneficiaries in the WestConnect Planning Region either: (a) through bilateral agreements that are voluntarily entered into between such Eligible Transmission Developer and the applicable identified beneficiaries; or (b)

by obtaining approval from FERC for project cost recovery pursuant to any other applicable section of the Federal Power Act.

6. Project Development Schedule.

The WestConnect PMC will not be responsible for managing the development of any project selected for inclusion in the Regional Plan. However, after having selected a project in the Regional Plan, the PMC will monitor the status of project's development. If a transmission facility is selected for inclusion in the Regional Plan for purposes of cost allocation, the transmission developer of that transmission facility must submit a development schedule that indicates the required steps, such as the granting of state approvals, necessary to develop and construct the transmission facility such that it meets the regional transmission needs of the WestConnect Planning Region. As part of the ongoing monitoring of the status of the regional transmission project once it is selected, the transmission owners and providers in the WestConnect Planning Region will establish a date by which the steps required to construct must be achieved that are tied to when construction must begin to timely meet the need that the project is selected to address. If such required steps have not been achieved by those dates, then the transmission owners and providers in the WestConnect Planning Region may remove the transmission project from the selected category and proceed with reevaluating the Regional Plan to seek an alternative solution.

7. Economic Benefits or Congestion Relief.

For a transmission project wholly within Black Hills' local transmission system that is undertaken for economic reasons or congestion relief at the request of a Requester, the project costs will be allocated to the Requester.

8. Black Hills Rate Recovery.

Notwithstanding the foregoing provisions, Black Hills will not assume cost responsibility for any transmission project if the cost of the project is not reasonably expected to be recoverable in its retail and/or wholesale rates.

9. Selection of a Transmission Developer for Sponsored and Un-sponsored Projects

For any project (sponsored or unsponsored) determined by the PMC to be eligible for regional cost allocation and selected in the Regional Plan for purposes of cost allocation, the PMC shall select a transmission project developer according to the processes set forth in this section, provided that selection according to those processes does not violate applicable law where the transmission facility is to be built that otherwise prescribes the entity that shall develop and build the project. Any entity that, pursuant to applicable law for the location where the facilities are to be built, chooses

to develop and build the project must submit a project development schedule as required by Section VII.B.6 of this Attachment K, within the timeframe directed by the Business Practice Manual, not to exceed the time period for request for proposal responses.

For any project determined by the PMC to be eligible for regional cost allocation and selected in the Regional Plan for purposes of cost allocation, either sponsored by a transmission developer or unsponsored, that is not subject to the foregoing paragraph, the PMC shall upon posting the selected projects, issue a request for information to all Eligible Transmission Developers under Section II.D.2 of this Attachment K soliciting their interest in developing the project(s). Each transmission developer shall respond to the request for information indicating its interest in developing the project. The PMC shall post on the WestConnect website the list of all transmission developers who responded with an expression of interest in developing the project(s). The PMC shall provide to each developer indicating interest in developing a project a request for proposals for the identified project(s) with a specified date of return for all proposals.

Each transmission developer, or partnership or joint ventures of transmission developers, shall submit information demonstrating its ability to finance, own and construct the project consistent with the guidelines for doing so set forth in the WestConnect Business Practices Manual. The PMC shall assess the submissions according to the following process and criteria:

The evaluation of the request for proposals will be at the direction of the PMC, and will involve representatives of the beneficiaries of the proposed project(s). The evaluation will include, but not be limited to, an assessment of the following evidence and criteria.

- General qualifications of the bidding entity;
- Evidence of financing/financial creditworthiness, including
 - financing plan (sources debt and equity), including construction financing and long-term financing
 - ability to finance restoration/forced outages
 - credit ratings
 - financial statements;
- Safety program and experience;
- Project description, including
 - detailed proposed project description and route
 - design parameters
 - design life of equipment and facilities
 - description of alternative project variations;
- Development of project, including
 - experience with and current capabilities and plan for obtaining state and local licenses, permits, and approvals
 - experience with and current capabilities and plan for obtaining

- any federal licenses and permits
- experience with and expertise and plan for obtaining rights of way
- development schedule
- development budget;
- Construction, including
 - experience with and current capabilities and plan for project construction
 - third party contractors
 - procurement plan
 - project management (cost and schedule control)
 - construction schedule
 - construction budget (including all construction and period costs);
- Operations, including
 - experience with and current capabilities and plan for project operation
 - experience with and current capabilities and plan for NERC compliance
 - security program and plan
 - storm/outage response plan
 - reliability of facilities already in operation;
- Maintenance capabilities and plans for project maintenance (including staffing, equipment, crew training, and facilities);
- Project cost to beneficiaries, including
 - total project cost (development, construction, financing, and other non-O&M costs)
 - operation and maintenance costs, including evaluation of electrical losses
 - revenue requirement, including proposed cost of equity, FERC incentives, proposed cost of debt and total revenue requirement calculation
 - present value cost of project to beneficiaries.

The PMC shall notify the developers of its determination as to which developer(s) it selected to develop the project(s) responsive to the request for proposal. The selected developer(s) must submit a project development schedule as required by Section VII.B.6 of this Attachment K.

If the PMC determines that a sponsored or unsponsored project fails to secure a developer through the process outlined in this section, the PMC shall remove the project from the Regional Plan.

After the PMC makes a determination, it will post a document on the WestConnect website within 60 days explaining the PMC's determination in selecting a particular transmission developer for a specific transmission project. The information will explain (1) the reasons why a particular transmission developer was selected or not selected, and, if applicable, (2) the reasons why a transmission project failed to secure a transmission developer.

10. No Obligation To Construct.

The Regional Planning Process is intended to determine and recommend the more efficient or cost-effective transmission solutions for the WestConnect Planning Region. After the Regional Plan is approved, due to the uncertainty in the Regional Planning Process and the need to address cost recovery issues, the Regional Planning Process shall not obligate any entity to construct, nor obligate any entity to commit to construct, any transmission facilities, regardless of whether such transmission facilities are included in any plan. Nothing in this Attachment K, the Business Practice Manual or the Planning Participation Agreement, or any cost allocation shall (1) determine any transmission service to be received by, or any transmission usage by, any entity; (2) obligate any entity to purchase or pay for, or obligate any entity to commit to purchase or pay for, any transmission service or usage; (3) entitle any entity to recover for any transmission service or usage or to recover from any entity any cost of any transmission facilities, regardless of whether such transmission facilities are included in any plan. Without limiting the generality of the foregoing, nothing in this Attachment K, the Business Practice Manual or the Planning Participation Agreement with respect to regional cost allocation shall preclude any WestConnect Planning Region member from satisfying its statutory requirements.

11. Binding Order No. 1000 Cost Allocation Methods

Order No. 1000 cost allocation methods as set forth in Section VII of this Attachment K are binding on identified beneficiaries in the WestConnect Planning Region, without prejudice to the following rights and obligations: (1) the right of a CTO, at its sole discretion, to decide whether to accept a regional cost allocation in accordance with Section III.E.6; (2) the right and obligation of the PMC to reevaluate a transmission facility previously selected for inclusion in the regional plan for purposes of Order No. 1000 cost allocation under Section III.E.7 of this Attachment K; (3) the right and obligation of a Eligible Transmission Developer to make a filing under Section 205 or other applicable provision of the Federal Power Act in order

to seek approval from the Commission to recover the costs of any transmission facility selected for inclusion in the regional plan for purposes of Order No. 1000 cost allocation; (4) the right and obligation of any interested person to intervene and be heard before the Commission in any Section 205 or other applicable proceeding initiated by an Eligible Transmission Developer, including the right of any identified beneficiaries of the transmission facility to support or protest the filing and to present evidence on whether the proposed cost recovery is or is not just and reasonable; and (5) the right and obligation of the Commission to act under Section 205 or other applicable provision of the Federal Power Act to approve or deny any cost recovery sought by an Eligible Transmission Developer for a transmission facility selected in the regional plan for purposes of Order No. 1000 cost allocation.⁷

12. Impacts of a Regional Project on Neighboring Planning Regions

The PMC is to study the impact(s) of a regional transmission project on neighboring planning regions, including the resulting need, if any, for mitigation measures in such neighboring planning regions. If the PMC finds that a regional transmission project in the WestConnect Planning Region causes impacts on a neighboring planning region that requires mitigation (a) by the WECC Path Rating Process, (b) under FERC OATT requirements, (c) under NERC Reliability Standards requirements, and/or (d) under any negotiated arrangement between the interconnected entities, the PMC is to include the costs of any such mitigation measures into the

7. An Eligible Transmission Developer may not be subject to the Commission's Section 205 jurisdiction. See Section VII.5. If an Eligible Transmission Developer is not subject to the Commission's jurisdiction under section 205 of the Federal Power Act, the Eligible Transmission Developer would have to seek to recover project costs from identified beneficiaries in the WestConnect Planning Region either: (a) through bilateral agreements that are voluntarily entered into between such Eligible Transmission Developer and the applicable identified beneficiaries; or (b) by obtaining approval from the Commission for project cost recovery pursuant to any other applicable section of the Federal Power Act.

regional transmission project's total project costs for purposes of determining the project's eligibility for regional cost allocation under the procedures identified in Section VII.B of this Attachment K, including application of the region's benefits-to-costs analysis.

The WestConnect Planning Region will not be responsible for compensating a neighboring planning region, transmission provider, transmission owner, Balancing Area Authority, or any other entity, for the costs of any required mitigation measures, or other consequences, on their systems associated with a regional transmission project in the WestConnect Planning Region, whether identified by the PMC or the neighboring system(s). The PMC does not direct the construction of transmission

facilities, does not operate transmission facilities or provide transmission services, and does not charge or collect revenues for the performance of any transmission or other services. Therefore, in agreeing to study the impacts of a regional transmission facility on neighboring planning regions, the PMC is not agreeing to bear the costs of any mitigation measures it identifies. However, the PMC will request of any developer of a regional transmission project selected in the Regional Plan for purposes of cost allocation that the developer design and build its project to mitigate the project's identified impacts on neighboring planning regions. If the project is identified as impacting a neighboring planning region that accords less favorable mitigation treatment to the WestConnect Planning Region than the WestConnect Planning Region accords to it, the PMC will request that the project developer reciprocate by using the lesser of (i) the neighboring region's mitigation treatment applicable to the mitigation of impacts of its own regional projects on the WestConnect Planning Region, or (ii) the PMC's mitigation treatment set forth above in sub-sections (a) through (d).

13. Exclusions

The cost for transmission projects undertaken in connection with requests for generation interconnection or transmission service on Black Hills' transmission systems, which are governed by the cost allocation methods within Transmission Provider's Tariff, will continue to be so governed and will not be subject to the principles of this Section VII.

VIII. Interregional Planning

This Part VIII of Attachment K to the OATT sets forth common provisions, which are to be adopted by or for each Planning Region and which facilitate the implementation of Order No. 1000 interregional provisions. WestConnect is to conduct the activities and processes set forth in this Part VIII of Attachment K to the OATT in accordance with the provisions of this Part VIII and the other provisions of this Attachment K to the OATT.

Nothing in this part will preclude any transmission owner or transmission provider from taking any action it deems necessary or appropriate with respect to any transmission facilities it needs to comply with any local, state, or federal requirements.

Any Interregional Cost Allocation regarding any ITP is solely for the purpose of developing information to be used in the regional planning process of each Relevant Planning Region, including the regional cost allocation process and methodologies of each such Relevant Planning Region.

References in this part to any transmission planning processes, including cost allocations, are references to transmission planning processes pursuant to Order No. 1000.

A. Definitions

The following capitalized terms where used in this Part VIII of Attachment K, are

defined as follows:

Annual Interregional Coordination Meeting: shall have the meaning set forth in Section VIII.C below.

Annual Interregional Information: shall have the meaning set forth in Section VIII.B below.

Interregional Cost Allocation: means the assignment of ITP costs between or among Planning Regions as described in Section VIII.E.2 below.

Interregional Transmission Project (“ITP”): means a proposed new transmission project that would directly interconnect electrically to existing or planned transmission facilities in two or more Planning Regions and that is submitted into the regional transmission planning processes of all such Planning Regions in accordance with Section VIII.D.1.

Order No. 1000 Common Interregional Coordination and Cost Allocation Tariff Language: means this Part VIII, which relates to Order No. 1000 interregional provisions.

Planning Region: means each of the following Order No. 1000 transmission planning regions insofar as they are within the Western Interconnection: California Independent System Operator Corporation, ColumbiaGrid, Northern Tier Transmission Group, and WestConnect.

Relevant Planning Regions: means, with respect to an ITP, the Planning Regions that would directly interconnect electrically with such ITP, unless and until such time as a Relevant Planning Region determines that such ITP will not meet any of its regional transmission needs in accordance with Section VIII.D.2, at which time it shall no longer be considered a Relevant Planning Region.

B. Annual Interregional Information Exchange

Annually, prior to the Annual Interregional Coordination Meeting, WestConnect is to make available by posting on its website or otherwise provide to each of the other Planning Regions the following information, to the extent such information is available in its regional transmission planning process, relating to regional transmission needs in WestConnect’s transmission planning region and potential solutions thereto:

1. study plan or underlying information that would typically be included in a study plan, such as:
 - a. identification of base cases;

- b. planning study assumptions; and
- c. study methodologies;
 - (i) initial study reports (or system assessments); and
 - (ii) regional transmission plan

(collectively referred to as “Annual Interregional Information”).

WestConnect is to post its Annual Interregional Information on its website according to its regional transmission planning process. Each other Planning Region may use in its regional transmission planning process WestConnect’s Annual Interregional Information. WestConnect may use in its regional transmission planning process Annual Interregional Information provided by other Planning Regions.

WestConnect is not required to make available or otherwise provide to any other Planning Region (i) any information not developed by WestConnect in the ordinary course of its regional transmission planning process, (ii) any Annual Interregional Information to be provided by any other Planning Region with respect to such other Planning Region, or (iii) any information if WestConnect reasonably determines that making such information available or otherwise providing such information would constitute a violation of the Commission’s Standards of Conduct or any other legal requirement. Annual Interregional Information made available or otherwise provided by WestConnect shall be subject to applicable confidentiality and CEII restrictions and other applicable laws, under WestConnect’s regional transmission planning process. Any Annual Interregional Information made available or otherwise provided by WestConnect shall be “AS IS” and any reliance by the receiving Planning Region on such Annual Interregional Information is at its own risk, without warranty and without any liability of WestConnect or any of the members of WestConnect, including any liability for (a) any errors or omissions in such Annual Interregional Information, or (b) any delay or failure to provide such Annual Interregional Information.

C. Annual Interregional Coordination Meeting

WestConnect is to participate in an Annual Interregional Coordination Meeting with the other Planning Regions. WestConnect is to host the Annual Interregional Coordination Meeting in turn with the other Planning Regions, and is to seek to convene such meeting in February, but not later than March 31st. The Annual Interregional Coordination Meeting is to be open to stakeholders. WestConnect is to provide notice of the meeting to its stakeholders in accordance with its regional transmission planning process.

At the Annual Interregional Coordination Meeting, topics discussed may include

the following:

1. each Planning Region's most recent Annual Interregional Information (to the extent it is not confidential or protected by CEII or other legal restrictions);
2. identification and preliminary discussion of interregional solutions, including conceptual solutions, that may meet regional transmission needs in each of two or more Planning Regions more cost effectively or efficiently; and
3. updates of the status of ITPs being evaluated or previously included in WestConnect's regional transmission plan.

D. ITP Joint Evaluation Process

1. Submission Requirements

A proponent of an ITP may seek to have its ITP jointly evaluated by the Relevant Planning Regions pursuant to Section VIII.D.2 by submitting the ITP into the regional transmission planning process of each Relevant Planning Region in accordance with such Relevant Planning Region's regional transmission planning process and no later than March 31st of any even-numbered calendar year. Such proponent of an ITP seeking to connect to a transmission facility owned by multiple transmission owners in more than one Planning Region must submit the ITP to each such Planning Region in accordance with such Planning Region's regional transmission planning process. In addition to satisfying each Relevant Planning Region's information requirements, the proponent of an ITP must include with its submittal to each Relevant Planning Region a list of all Planning Regions to which the ITP is being submitted.

2. Joint Evaluation of an ITP

For each ITP that meets the requirements of Section VIII.D.1, WestConnect (if it is a Relevant Planning Region) is to participate in a joint evaluation by the Relevant Planning Regions that is to commence in the calendar year of the ITP's submittal in accordance with Section VIII.D.1 or the immediately following calendar year. With respect to any such ITP, WestConnect (if it is a Relevant Planning Region) is to confer with the other Relevant Planning Region(s) regarding the following:

- a. ITP data and projected ITP costs; and
- b. the study assumptions and methodologies it is to use in evaluating the ITP pursuant to its regional transmission planning process.

For each ITP that meets the requirements of Section VIII.D.1, WestConnect

(if it is a Relevant Planning Region):

- a. is to seek to resolve any differences it has with the other Relevant Planning Regions relating to the ITP or to information specific to other Relevant Planning Regions insofar as such differences may affect WestConnect's evaluation of the ITP;
- b. is to provide stakeholders an opportunity to participate in WestConnect's activities under this Section VIII.D.2 in accordance with its regional transmission planning process;
- c. is to notify the other Relevant Planning Regions if WestConnect determines that the ITP will not meet any of its regional transmission needs; thereafter WestConnect has no obligation under this Section VIII.D.2 to participate in the joint evaluation of the ITP; and
- d. is to determine under its regional transmission planning process if such ITP is a more cost effective or efficient solution to one or more of WestConnect's regional transmission needs.

E. Interregional Cost Allocation Process

1. Submission Requirements

For any ITP that has been properly submitted in each Relevant Planning Region's regional transmission planning process in accordance with Section VIII.D.1, a proponent of such ITP may also request Interregional Cost Allocation by requesting such cost allocation from WestConnect and each other Relevant Planning Region in accordance with its regional transmission planning process. The proponent of an ITP must include with its submittal to each Relevant Planning Region a list of all Planning Regions in which Interregional Cost Allocation is being requested.

2. Interregional Cost Allocation Process

For each ITP that meets the requirements of Section VIII.E.1, WestConnect (if it is a Relevant Planning Region) is to confer with or notify, as appropriate, any other Relevant Planning Region(s) regarding the following:

- a. assumptions and inputs to be used by each Relevant Planning Region for purposes of determining benefits in accordance with its regional cost allocation methodology, as applied to ITPs;
- b. WestConnect's regional benefits stated in dollars resulting from the ITP, if any; and

- c. assignment of projected costs of the ITP (subject to potential reassignment of projected costs pursuant to Section VIII.F.2 below) to each Relevant Planning Region using the methodology described in this Section VIII.E.2.

For each ITP that meets the requirements of Section VIII.E.1, WestConnect (if it is a Relevant Planning Region):

- a. is to seek to resolve with the other Relevant Planning Regions any differences relating to ITP data or to information specific to other Relevant Planning Regions insofar as such differences may affect WestConnect's analysis;
- b. is to provide stakeholders an opportunity to participate in WestConnect's activities under this Section VIII.E.2 in accordance with its regional transmission planning process;
- c. is to determine its regional benefits, stated in dollars, resulting from an ITP; in making such determination of its regional benefits in WestConnect, WestConnect is to use its regional cost allocation methodology, as applied to ITPs;
- d. is to calculate its assigned *pro rata* share of the projected costs of the ITP, stated in a specific dollar amount, equal to its share of the total benefits identified by the Relevant Planning Regions multiplied by the projected costs of the ITP;
- e. is to share with the other Relevant Planning Regions information regarding what its regional cost allocation would be if it were to select the ITP in its regional transmission plan for purposes of Interregional Cost Allocation; WestConnect may use such information to identify its total share of the projected costs of the ITP to be assigned to WestConnect in order to determine whether the ITP is a more cost effective or efficient solution to a transmission need in WestConnect;
- f. is to determine whether to select the ITP in its regional transmission plan for purposes of Interregional Cost Allocation, based on its regional transmission planning process; and
- g. is to endeavor to perform its Interregional Cost Allocation activities pursuant to this Section VIII.E.2 in the same general time frame as its joint evaluation activities pursuant to Section VIII.D.2.

F. Application of Regional Cost Allocation Methodology to Selected ITP

1. Selection by All Relevant Planning Regions

If WestConnect (if it is a Relevant Planning Region) and all of the other Relevant Planning Regions select an ITP in their respective regional transmission plans for purposes of Interregional Cost Allocation, WestConnect is to apply its regional cost allocation methodology to the projected costs of the ITP assigned to it under Section VIII.E.2(d) or VIII.E.2(e) above in accordance with its regional cost allocation methodology, as applied to ITPs.

2. Selection by at Least Two but Fewer than All Relevant Regions

If WestConnect (if it is a Relevant Planning Region) and at least one, but fewer than all, of the other Relevant Planning Regions select the ITP in their respective regional transmission plans for purposes of Interregional Cost Allocation, WestConnect is to evaluate (or reevaluate, as the case may be) pursuant to Sections VIII.E.2(d), VIII.E.2(e), and VIII.E.2(f) above whether, without the participation of the non-selecting Relevant Planning Region(s), the ITP is selected (or remains selected, as the case may be) in its regional transmission plan for purposes for Interregional Cost Allocation. Such reevaluation(s) are to be repeated as many times as necessary until the number of selecting Relevant Planning Regions does not change with such reevaluation.

If following such evaluation (or reevaluation), the number of selecting Relevant Planning Regions does not change and the ITP remains selected for purposes of Interregional Cost Allocation in the respective regional transmission plans of WestConnect and at least one other Relevant Planning Region, WestConnect is to apply its regional cost allocation methodology to the projected costs of the ITP assigned to it under Sections VIII.E.2(d) or VIII.E.2(e) above in accordance with its regional cost allocation methodology, as applied to ITPs.

Exhibit 1



Regional Planning Process Activity	Activity Timeframe
Stakeholder meetings	WestConnect will hold open stakeholder meetings on at least a semi-annual basis, or as needed and notified by the PMC with 30 days advance notice, to update stakeholders about its progress in developing the Regional Plan and to solicit input regarding material matters of process related to the regional transmission plan.
Base transmission plan data collection window	The PS will initiate development of the base transmission plan no later than Quarter 3 of the previous biennial planning cycle and in conjunction with initiating the development of the Regional Study Plan. The submittal window for projects to be considered as part of the base transmission plan will be noticed a minimum of 15 days before the window opens, and the submittal window will stay open for a minimum of 30 days.
Scenario submittal window	A scenario submittal window will open when the development of the Regional Study Plan commences and no later than Quarter 3 of the previous biennial planning cycle. The scenario submittal window will be noticed a minimum of 15 days before the window opens, and the submittal window will stay open for a minimum of 30 days.
Identification of regional needs	Identified regional needs will be posted to the WestConnect website no later than close of Quarter 4 of the first year of the biennial cycle.
Submission Period for Regional Projects to Address Identified Regional Needs	For consideration in the current planning cycle, projects must be submitted following the posting of identified regional needs to the WestConnect website, and must occur before the end of Quarter 5 of the biennial planning cycle. Any project submitted after this date will be considered in the next subsequent planning cycle.

Black Hills Energy OATT Attachment K Business Practice

ATTACHMENT K BUSINESS PRACTICE

BLACK HILLS/COLORADO ELECTRIC, LLC

April 8, 2010

Table of Contents

Introduction	5
FERC 890 Summary	5
Principle 1 – Coordination	5
Order 890 Requirement	5
Stakeholder Coordination in the Transmission Planning Process	6
Information	7
Comparable Stakeholder Involvement	8
Planning Meetings	8
Meeting Information	8
Stakeholder Communications	9
Sub-Regional Coordination	9
Principle 2 – Openness	10
FERC Order Requirement Summary	10
Transmission Provider Open Planning Process	10
Meetings	10
Standards of Conduct and Critical Energy Information	10
Confidentiality	10
Sub-Regional and Regional Planning	11
Principle 3 – Transparency	11
FERC Order Requirement Summary	11
Technical Analyses Transparency	11
Consistent Application	12
Data Access	12
Opportunity for Review and Comment	12
Replication of Planning Studies	13
Regional Transparency	13
Principle 4 - Information Exchange	13
FERC Order Requirement Summary	13
Information Request	13

Procedure for Data Submission	14
Data Use in Planning Process	14
Confidentiality	14
Customer Responsibility	14
Principle 5 – Comparability	15
FERC Order Requirement Summary	15
Ensuring Comparability	15
Principle 6 - Dispute Resolution	16
FERC Order Requirement Summary	16
Transmission Provider Dispute Resolution	16
Principle 7 - Regional Participation	16
FERC Order Requirement Summary	16
Transmission Provider Actions	16
Transmission Planning Coordination Flow	17
Sub-Regional Participation	17
CCPG-WestConnect	17
Plan and Data Coordination	18
Regional Participation	18
Transmission Provider and Sub-Regional Planning Process Differences	19
Simultaneous Plan Feasibility	20
Principle 8 - Economic Planning Studies	20
FERC Order Requirement Summary	20
Transmission Provider Actions	21
Study Description	21
High-Priority Study Requests	22
Requesting A High-Priority Economic Planning Study	22
Valid Request	22
Economic Planning Study Classification	22
Prioritizing Economic Study Requests	23

Local Transmission Provider Economic Planning Study	23
Customer’s Obligation To Share Data	24
The Transmission Provider Obligation	25
Transmission Provider Economic Planning Study Timeline and Process	25
Additional Economic Studies	26
Process for Additional Economic Planning Studies	26
Principle 9 - Cost Allocation for New Projects	27
FERC Order Requirement Summary	27
Projects Not Covered Under Existing Cost Allocation Rules	27
Transmission Provider Allocation Methodology	28
Sub-Regional and Regional Cost Allocation	29
Recovery of Planning Costs	29
Appendix 1	30
Transmission Coordination and Planning Committee Charter	30
I. Purpose	30
II. TCPC Membership	30
III. Decisions	31
IV. Process	31
V. Member Responsibilities	31
VVI. Confidentiality	32
VII. Antitrust Policy	32
VII. Standards of Conduct Policy and Safeguards	32

Introduction

Black Hills/Colorado Electric, LLC (referred to hereinafter as the Transmission Provider) owns and operates certain transmission facilities with transmission service pursuant to a FERC approved Open Access Transmission Tariff (“OATT”). The Transmission Provider will be responsible for meeting all applicable requirements of the FERC Order 890.

In accordance with the Commission’s regulations, the Transmission Provider planning process is performed on a local, sub-regional and regional basis. The Transmission Provider will develop a Local Transmission Plan (“LTP”) which will identify transmission system improvements and/or additions necessary to reliably satisfy, over the planning horizon, Network Customers’ resource and load growth expectations for designated Network Load; Transmission Provider’s resource

and load growth expectations for Native Load Customers; Transmission Provider's obligations pursuant to grandfathered, non-OATT agreements; and the Transmission Provider's Point-to-Point customers' projected service needs including obligations for rollover rights.

FERC 890 Summary

The Federal Energy Regulatory Commission ("FERC") issued Order No. 890 on February 16, 2007. The intent of this Order is to remedy opportunities for undue discrimination and address deficiencies in the pro forma open access transmission tariff ("pro forma OATT"). The Commission therefore amended its regulations and the pro forma OATT, adopted in Order Nos. 888 and 889.

To remedy the potential for undue discrimination in planning activities, the Commission directed all transmission providers to develop a transmission planning process that satisfies nine planning principles with an emphasis on coordination, openness, transparency and stakeholder input. The nine principles are: Coordination, Openness, Transparency, Information Exchange, Comparability, Dispute Resolution, Regional Participation, Economic Planning Studies, and Cost Allocation for new projects. This Attachment K defines how the Transmission Provider will comply with these nine principles now mandated by the FERC in Order 890. Attachment K can be found on the Transmission Providers OASIS at <http://www.oatioasis.com/BHCT>.

Principle 1 – Coordination

Order 890 Requirement

The Coordination principle requires appropriate communication among transmission providers, transmission-providing neighbors, state authorities, customers, and other stakeholders. Transmission providers are allowed to develop coordination requirements with input from their customers and other stakeholders. Coordination requirements will be tailored for respective transmission provider and stakeholder needs.

Stakeholder Coordination in the Transmission Planning Process

The Transmission Provider will have an open process that allows and promotes customers, interconnected neighbors, regulatory and state bodies and other stakeholders to participate in a coordinated nondiscriminatory process for transmission plan development. To accomplish this coordination, the Transmission Provider will have a process as shown below that will afford stakeholders an opportunity to provide input on methodologies, processes and other elements used in the development of the LTP. The Transmission Provider will have an open process to allow two-way communications with stakeholders and sub-regional and regional planning organizations.

Furthermore, the Transmission Provider will create a stand alone advisory committee named the Transmission Coordination and Planning Committee ("TCPC"). The purpose of TCPC is to provide an open transparent forum whereby electric transmission stakeholders can comment and provide advice to the Transmission Provider during all stages of its transmission planning process. The TCPC charter is further defined in **Attachment 1**.

As can be seen in **Figure 2** below, stakeholder input occurs throughout the planning cycle via the TCPC. A brief description of how the TCPC provides input to the various phases of the LTP study process is provided below. The ultimate responsibility for the LTP will however remain with Transmission Provider and therefore the TCPC will not make decisions or implement the LTP.

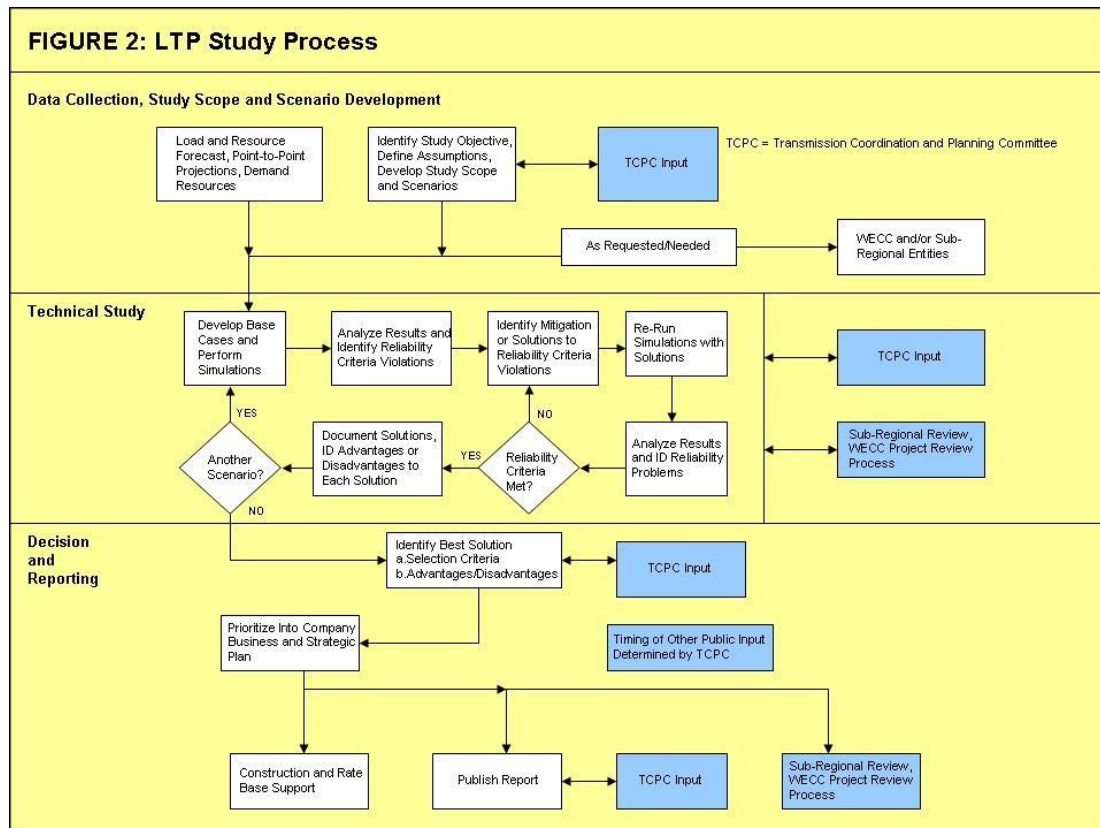

Data Collection, Study Scope and Scenario Development: As can be seen in **Figure 2** above, this portion of the planning process includes coordination and input from the TCPC. The Transmission Provider will work with TCPC to identify the study objectives, assumptions, study plan and pertinent scenarios that should be studied in order to meet various stakeholder needs. A scenario will depict a specific condition such as peak load, maximum area generation, maximum export, etc.

Technical Study: The Technical Study phase of the planning process also includes coordination and input from the TCPC. Once the scenarios are defined, the technical study will begin by developing basecases that specify the modeling information for the scenario. The process will end with identification of technical solutions. The TCPC will provide input into the advantages and disadvantages of each solution.

Decision: As noted above, the Transmission Provider will seek input from the TCPC in identifying the specific selection criteria used for the decision. This information along with documented advantages and disadvantages of each solution will be used to aid in selecting the best solution or mitigation. The primary purpose of the decision phase is to provide information about the system problem and identify solutions or mitigations that resolve the problem. The

Transmission Provider management will use this information to make an informed decision for future transmission investments needed to service all classes of Transmission Provider customers.

Reporting: The Transmission Provider will develop an LTP report for the above information. This report will describe the scenarios, technical studies, decision criteria and how the plan was developed. With the aid of the TCPC, the Transmission Provider will make every attempt to clearly describe the methodology, criteria, and process that clarify how the LTP was developed.

The LTP study process is fully described in the document “Transmission System Planning Methodology, Criteria and Process Business Practice” located on the Transmission Provider OASIS at <http://www.oatioasis.com/BHCT> within the Transmission Planning folder

Information

To simplify stakeholder involvement and understanding of the LTP study process, an area on the Transmission Provider OASIS website (<http://www.oatioasis.com/BHCT>) dedicated to Transmission Planning has been established. Within the Transmission Planning folder the stakeholders can learn about the Transmission Provider planning activities including:

- past meeting information and minutes, •
future meeting announcements,
- Transmission Provider calendar of events, •
reports and meeting material,
- Transmission Provider contact information.

Stakeholders will have access to all information and material presented or discussed at the TCPC meetings subject to confidentiality requirements. As will be described below, stakeholders can participate in the TCPC meetings by attending the meeting via conference call or other means.

Interested parties can also contact and provide comments directly to the Transmission Provider by accessing the “How To Contact Us” file within the “Transmission Planning” folder on the Transmission Provider OASIS website (<http://www.oatioasis.com/BHCT>). The Transmission Provider will seek input during the development of the LTP by allowing interested parties to participate in meetings, becoming a member of the TCPC or by contacting the Transmission Provider through email or written comments.

Comparable Stakeholder Involvement

The LTP planning process is designed to avoid discrimination in transmission system planning and will involve all stakeholders on a comparable basis. The process will open appropriate lines of communication between transmission providers, transmission-providing neighbors, affected state authorities, customers, and other stakeholders. The Transmission Provider will make its meetings open to all stakeholders, except when Standards of Conduct (SOC) or confidentiality

concerns require portions of the meeting to be closed to some participants. The Transmission Provider LTP study process will allow participation by stakeholders, including, but not limited to, state regulators, transmission customers (network and point-to-point), interconnected generators, interconnecting utilities, neighboring transmission providers and other stakeholders.

Planning Meetings

As noted above, the Transmission Provider will form a permanent planning and coordination committee named the Transmission Coordination and Planning Committee. The TCPC will be actively engaged throughout all stages of the LTP planning process. The purpose of this committee will be to provide input to the Transmission Provider and will be actively engaged throughout all stages of the LTP study process. The TCPC will not make decisions or implement the plan. The ultimate responsibility for the transmission plan will remain with Transmission Provider and therefore the TCPC will not make decisions or implement the transmission plan. The TCPC charter is further defined in **Attachment 1**.

Meeting Information

The number of meetings, scope, notice requirements, and the format of the TCPC meetings are described below.

Number of Meetings: The TCPC will meet quarterly in an open forum. The TCPC may hold additional meetings as needed to provide meaningful input into the LTP study process, including but not limited to review of gathered data and study scenario development; review of study results; review of draft transmission plans; and coordination of draft plans with those of neighboring transmission providers.

Scope of Meetings: The meetings will be open to discuss non-confidential aspects of transmission planning activities including, but not limited to process, methodology, assumptions, study inputs, criteria, and study results. The intent is to provide a forum that allows stakeholders to have meaningful input throughout the Transmission Provider LTP study process. Dissemination of market sensitive information or critical infrastructure information must follow FERC Standards of Conduct (SOC) and Critical Energy Infrastructure Information (CEII) requirements.

Notice: There will two forms of meeting notice: (1) A list of participants (name, organization, phone and email) will be maintained and a notice for each meeting will be provided to prior participants by email; and (2) Notice of a TCPC meeting will be posted on the Transmission Provider OASIS website at least ten (10) business days prior to the meeting. The Transmission Planning folder of the Transmission Provider OASIS website will include a file containing the names, addresses and phone numbers for the Transmission Provider Points of Contact.

Format: The Transmission Provider or other designated party will facilitate and manage the TCPC meetings. The meetings will be designed to provide opportunities for information exchange about the Transmission Provider transmission plans, methodology and processes. Meetings may be conducted face-to-face, by conference call, by web conference or a

combination thereof. Meeting notes and presented information will be posted on the Transmission Provider OASIS website.

Stakeholder Communications

Any pertinent information or announcements will be posted on the Transmission Provider OASIS website.

Sub-Regional Coordination

The Transmission Provider is an active participant in the Colorado Coordinated Planning Group (CCPG) and WestConnect. The Transmission Provider will coordinate its transmission plan with the appropriate sub-regional planning group and with other planning entities as required. CCPG, through WestConnect, will coordinate its planning proposals with WECC and other sub-regional planning groups. CCPG is an open stakeholder processes which holds open forum meetings. WestConnect holds publicly noticed open stakeholder meetings. Information regarding CCPG and WestConnect can be found at http://www.westconnect.com/planning_ccpg.php and <http://www.westconnect.com> respectively.

Principle 2 – Openness

FERC Order Requirement Summary

The Openness principle requires that Transmission Planning meetings be open to all affected parties, including but not limited to all transmission and interconnection customers, state commissions and other stakeholders. If subcommittees or working groups are used, the overall transmission plan and planning process must remain open.

Transmission Provider Open Planning Process

The Transmission Provider LTP planning process will be open to all stakeholders via the TCPC as shown in Figure 2 above. Stakeholders will have the opportunity to review and comment on the LTP throughout the entire process, from data collection to review of the final report. This process is described in Principle 3 - Transparency and in the document “Transmission System Planning Methodology, Criteria and Process Business Practice” located on the Transmission Provider OASIS website. Once the LTP is developed, the Transmission Provider will work with TCPC to produce a report that is clear and understandable.

Meetings

The TCPC meetings will be open to all stakeholders for participation and input.

Standards of Conduct and Critical Energy Information

Protection of Critical Energy Infrastructure Information (CEII) and market sensitive information covered by FERC Standards of Conduct (SOC) will be observed.

Confidentiality

Access to confidential data by a stakeholder will require a confidentiality agreement. There are two confidentiality agreements that apply – The Transmission Provider confidentiality agreement for Transmission Provider or stakeholder confidential data and a WECC confidentiality agreement for confidential WECC base case data. Access to additional sub-regional or regional data may require additional confidentiality agreements.

- Access to the Transmission Provider confidential data will require signing the Transmission Provider confidentiality agreement. A copy of Transmission Provider confidentiality agreement will be posted on the Transmission Provider OASIS website.
- Access to WECC load and resource data and WECC base case data will require signing a WECC confidentiality agreement. It should be noted that a confidentiality agreement is not required for WECC members to obtain access to base case data.
- The Transmission Provider will apply equal protection to both Transmission Provider and customer confidential information. It is recognized that certain data may not be available to certain participants, even though a confidentiality agreement is signed, due to their relationship to the market or their need to know.

Disclosure of confidential data to state commissions, FERC and other regulatory bodies may be governed by an appropriate protective order. Before confidential data is released to regulating bodies, the Transmission Provider may seek protection of that data through a protective order.

Access to confidential information through the Transmission Provider OASIS website will be protected by controlling access to the information. If necessary, a password-protected site may be created by the Transmission Provider to facilitate distribution of confidential information in a controlled manner. Access to confidential information must be approved by the Transmission Provider and anyone who is granted access will receive a login ID and a password from the Transmission Provider.

Sub-Regional and Regional Planning

With respect to sub-regional and regional planning entity openness, the Transmission Provider will coordinate and provide CCPG, WestConnect and WECC the LTP, associated assumptions and other information as requested. Confidential data will be protected through the Transmission Provider confidentiality requirements or the confidentiality requirements of the sub-regional and regional entities.

Principle 3 – Transparency

FERC Order Requirement Summary

The Transparency principle requires disclosure of basic methodology, criteria, assumptions, process and data that underlie transmission system plans. Methodologies, criteria and processes

must be published and consistently applied. The Standards of Conduct (SOC) compliance to the release of certain information is critical.

Technical Analyses Transparency

The Transmission Provider will disclose its basic methodology, criteria, process and data used to develop its transmission plan. This information is fully defined in the document “Transmission System Planning Methodology, Criteria and Process Business Practice” located on the Transmission Provider OASIS website.

The Technical Study phase within the LTP study process will use engineering studies to evaluate system performance against established criteria. Transparency of the Technical Study phase will be foremost in the LTP study process and will be achieved through open communications with TCPC members. The technical studies are designed to use different engineering perspectives to ensure system reliability is maintained. In addition, applicable NERC and WECC system performance standards will be followed when performing technical studies. Analysis methods may include, but are not limited to the following:

- Steady-State Powerflow Analyses
- Post Transient Steady-State Powerflow Analyses
- Transient Stability Analyses
- Short Circuit Fault Duty Analyses
- Reactive Margin Analyses
- Additional studies deemed necessary by the Transmission Provider.

Consistent Application

The Transparency Principle requires a discussion as to how retail native loads are treated, in order to ensure that standards are consistently applied. The openness and transparency of the Transmission Provider LTP study process will ensure consistent application of methodologies, criteria, and processes to all customers’ studies. Therefore, all customers will be treated on an equal and comparable basis using the LTP study process described in this business practice and Attachment K. Moreover, the TCPC will provide additional oversight to ensure consistent application of the planning process and associated principles

Data Access

Stakeholders can obtain access to data used in the LTP study process by directly contacting the Transmission Provider if this data is not available on the public portion of the Transmission

Provider OASIS website. The Transmission Provider contact information is provided in the “How To Contact Us” document in the “Transmission Planning” folder on the Transmission Provider OASIS website.

Opportunity for Review and Comment

Stakeholders, through the TCPC meeting, published documentation or written correspondence, will have full opportunity to review, discuss and comment on the Transmission Provider’s assumptions, study plan, scenarios, methodologies, criteria or other planning related items. This process is further described above in Principle 1- Coordination and in the “Transmission System Planning Methodology, Criteria and Process Business Practice” located on the Transmission Provider OASIS website. The Transmission Provider will seek input during the Data Collection phase of the LTP study process by encouraging interested stakeholders to participate in the TCPC meetings, becoming a member of the TCPC or by contacting the Transmission Provider through email or other written correspondence. As noted previously, Transmission Provider contact information can be found on the Transmission Provider OASIS website.

The Transmission Provider will use the Transmission Provider OASIS website postings and TCPC meetings to disseminate information to help achieve the objectives of the Transparency and other planning principles. Stakeholders will have access to non-confidential data, study results and other information within the Transmission Planning folder on Transmission Provider OASIS website. If necessary, a password-protected site may be created by the Transmission Provider to facilitate distribution of confidential information in a controlled manner. Access to confidential information must be approved by the Transmission Provider and anyone who is granted access will receive a login ID and a password from the Transmission Provider.

Planning information and study results will be presented at TCPC meetings and posted on the Transmission Provider OASIS website. Study results will be presented in a manner that is clear to stakeholders. The LTP report will be designed to provide a clear understanding to stakeholders and will include technical sections to present engineering results. The Transmission Provider will obtain input from the TCPC in writing the report and developing the LTP.

Replication of Planning Studies

This information with appropriate base case data and the Siemens PTI PSS/E software will enable customers, stakeholders or independent third parties to replicate the results of the Transmission Provider powerflow studies. A confidentiality agreement will be required for use of WECC base cases. WECC members can obtain base cases directly from the WECC.

Regional Transparency

In the region, the Transmission Provider will participate in and rely on CCPG, WestConnect and WECC transparency documentation for major projects that involve the Transmission Provider transmission system.

Principle 4 - Information Exchange

FERC Order Requirement Summary

The Information Exchange principle requires transmission customers to submit information on projected loads and resources. Network, native load and point-to-point customer information is to be supplied on a comparable basis. The Transmission Provider must develop guidelines and a schedule for load data submittals from network and point-to-point customers. The information collected by the Transmission Providers to provide transmission service to their native load customers must be transparent, and equivalent information must be provided by transmission customers to ensure effective planning and comparability.

Information Request

- The Transmission Provider will request load and generation information from customers that will be used to meet its transmission planning requirements and to meet the requirements of Attachment K. The Transmission Provider will tailor its request for information from Load Serving Entities (LSE) and other customers after the annual WECC Loads and Resources data request and the WECC Power Supply Assessment data request. The Transmission Provider will augment the WECC data requests with requests for other transmission planning data as necessary to study the transmission system. The Transmission Provider will gather historical data, forecast data and other load and generation data as defined in Attachment K and the “Transmission System Planning Methodology, Criteria and Process Business Practice”.
- Use and Confidentiality: The data received will be used to develop the Transmission Provider LTP and confidential data will be administered according to SOC and CEII requirements.
- The Transmission Provider will request forecast data annually during the fourth quarter. This annual schedule will be merged with the annual Transmission Provider LTP study cycle. A description of the data to be collected can be found in the “Transmission System Planning Methodology, Criteria and Process Business Practice”. This data collection timeline is linked to WECC Load and Resource Data Request submission in December of the calendar year. This schedule may be adjusted if WECC changes its data request response time frames. The Transmission Provider will provide as much advance notice as possible for changes.

Procedure for Data Submission

The customer will provide data in Excel workbook format. A template workbook is available on the Transmission Provider OASIS website. Additionally, a customer can submit requested data in other formats, such as formats required by WECC.

Data Use in Planning Process

All appropriate customer forecast data will be used in the Transmission Provider LTP study.

Confidentiality

The Transmission Provider will keep all customer specific data confidential. CEII and WECC base case data are confidential, but can be obtained by signing the appropriate confidentiality agreement. However, some confidential data may not be available to marketing entities/individuals because of the market sensitive nature of the information (e.g., generator or line maintenance outages).

Customer Responsibility

Pursuant to Attachment K, Transmission Customers should provide the Transmission Provider with generation, load forecast, and demand response resource information to the maximum extent practical and consistent with protection of proprietary information. Customers should also provide timely written or email notice of material changes to information previously provided relating to its load, resources, or other aspects of its facility or operations affecting the Transmission Provider's ability to provide service.

Principle 5 – Comparability

FERC Order Requirement Summary

The Comparability principle requires the Transmission Provider to develop a transmission plan, after considering the data and comments supplied by customers and other stakeholders, that: 1) meets the specific service requests of its transmission customers; and 2) provides comparable treatment to similarly situated customers (network and retail native load). Customer demand resources should be considered on a comparable basis to the service provided by comparable generation resources.

Ensuring Comparability

Once the Transmission Provider has received the data, the LTP will be developed after considering and including appropriate stakeholder comments on assumptions, study plan, data, processes and methodology. To ensure comparability, all valid customer data will be included and equally considered in the reliability assessment.

Combining the forecast load and generation information received from the customers with Transmission Provider transmission line and equipment data for the desired year to be studied develops the base cases used in a technical reliability assessment. The load forecast and/or generation dispatch patterns can be varied independently to produce worst case system stress, or depict a specific operating condition such as the summer peak season. The Transmission Provider does not conduct studies for every possible load and resource dispatch combination, but only the load and resource dispatch patterns that stress the transmission system are evaluated.

These base cases that stress the transmission system are then used in a computer simulation to evaluate system performance against established criteria.

The transmission system is evaluated with all transmission lines in service (system intact) and with a variety of transmission and generation facilities out of service. For each computer simulation run, the transmission system voltage, transmission facility loading, reactive support and other parameters are measured against established reliability criteria. If the reliability criteria are not met, then appropriate mitigation (transmission and/or non-transmission solution) is modeled in the base case and the computer model simulation is run again. This iterative process continues until all reliability criteria are met. The mitigation measures could include enhancements to the transmission system, generation development, demand resource development or other alternatives. Because this assessment is based on established criteria and predetermined load and generation dispatch scenarios, there is no discrimination to any customer type. The Transmission Provider believes this process and resulting LTP will treat similarly situated customers in a comparable manner and therefore, the Comparability principle will be met.

Principle 6 - Dispute Resolution

FERC Order Requirement Summary

The Dispute Resolution principle requires an Alternate Dispute Resolution (ADR) process be available to manage disputes that arise from the planning process. An ADR must address both substantive and procedural planning disputes. Three steps should be included in the ADR process: 1) Negotiation, 2) Mediation, and 3) Arbitration. Existing ADR procedures can be used if appropriate.

Transmission Provider Dispute Resolution

Dispute resolution is fully described in Attachment K.

Any dispute between a Transmission Customer and the Transmission Provider involving transmission service under the Tariff will be governed by the Dispute Resolution Procedure described in Section 12 of the Transmission Provider OATT.

Principle 7 - Regional Participation

FERC Order Requirement Summary

The Regional Participation principle requires Transmission Providers to coordinate with interconnected systems to: 1) share system plans to ensure they are simultaneously feasible and otherwise use consistent assumptions and data, and 2) identify system enhancements that could relieve congestion or integrate new resources. The existing regional processes may be used if they are open and inclusive, address both reliability and economic considerations, and coordinate these issues across the region. Sub-regions must have adequate scope and coordination.

Transmission Provider Actions

The Transmission Provider participation in regional and sub-regional planning activities will be broad, ranging from providing data to providing the Transmission Provider transmission plan to participating in sub-regional and regional studies and committees. The Transmission Provider transmission plan associated data and assumptions will be shared with interconnected transmission systems, sub-regions and region entities as required or requested. The Transmission Provider base case data and its transmission plan will be provided when appropriate and with the confidential data protected.

Transmission Planning Coordination Flow

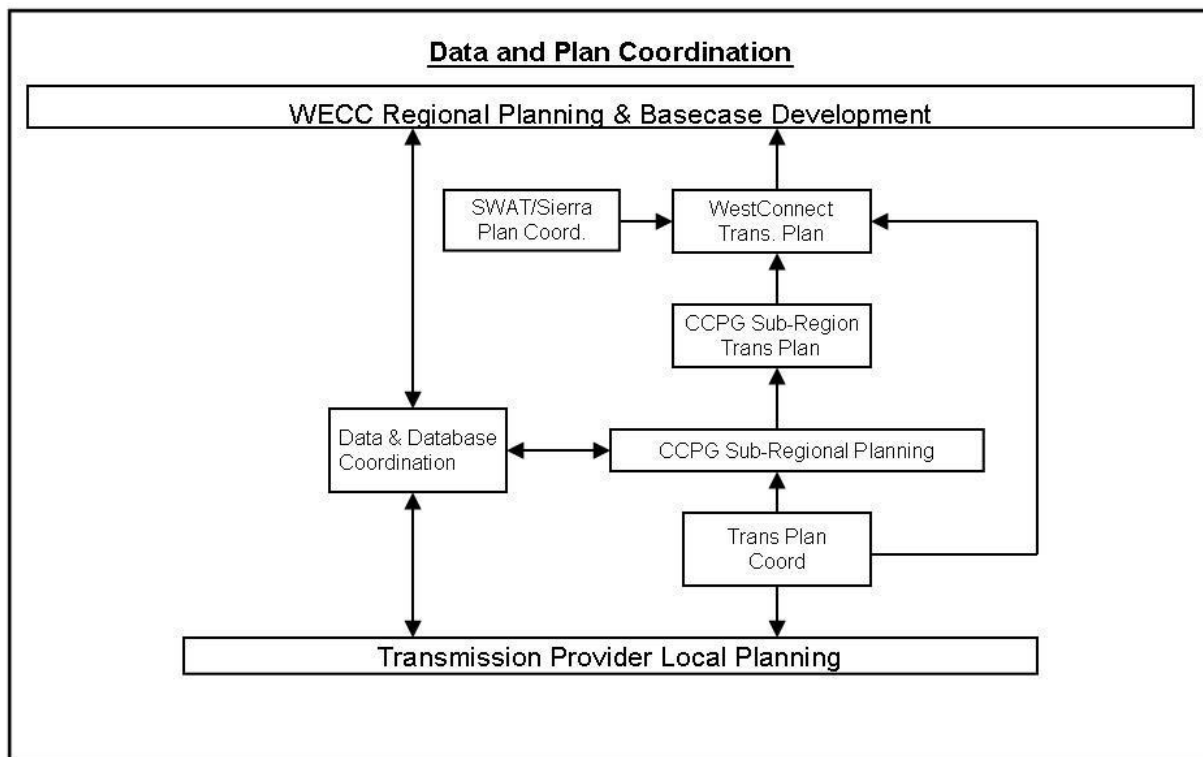

Figure 3: Local, Sub-Regional and Regional Planning

Sub-Regional Participation

In the sub-regional context, the Transmission Provider is an active participant of the Colorado Coordinated Planning Group (“CCPG”) and a member of WestConnect.

CCPG-WestConnect

CCPG’s footprint includes the geographic areas of Colorado, Eastern Wyoming, Western South Dakota and Western Nebraska. The CCPG holds open forum meetings which are well attended by utilities, regulatory staff, merchants and other stakeholders. The CCPG exists to aid in coordinated planning under the single-system planning concept within the CCPG footprint, along with conducting sub-regional reliability assessments and facilitating development of joint business opportunities. Many CCPG members are also members of WestConnect. WestConnect is composed of utility companies providing transmission of electricity in the southwestern United States. WestConnect’s intent is to collaboratively assess stakeholder and market needs and to develop cost-effective enhancements to the western wholesale electricity market. On February 26, 2006 CCPG adopted the “Principals for Sub-Regional Transmission Planning” (“Principals”) document. The Principals document was developed with WestConnect and Southwest Area Transmission (“SWAT”) to identify the contributions CCPG and SWAT will each make to support the WestConnect transmission planning goals. These principals include:

- Conduct a biennial near and long-term transmission system plan in accordance with NERC/WECC planning criteria.
- Provide input to a single near and long-term transmission plan produced by WestConnect to address the WestConnect footprint.
- Ensure that the CCPG and SWAT transmission plans are developed within the same cycle.
- Coordinate base case development.
- Coordinate and share planning efforts between the three entities.
- Develop coordinated transmission plans as appropriate.

WestConnect has outlined their transmission planning process in “WestConnect Objectives and Procedures for Regional Transmission Planning”. This document was developed by the WestConnect membership and outlines the planning process they will implement to coordinate transmission planning between SWAT and CCPG, and ultimately with WECC. The document can be found on the WestConnect website at <http://www.westconnect.com>.

Plan and Data Coordination

The Transmission Provider will coordinate and submit its data, assumptions and transmission system plan to CCPG and WestConnect for inclusion in the WestConnect Transmission Plan. See Figure 3: Local, Sub-Regional and Regional Planning. The Transmission Provider customers or other stakeholders can be directly involved in Transmission Provider planning through participation and membership of the TCPC. Transmission Provider customers or other stakeholders can also be directly involved in CCPG sub-regional planning, see information on the CCPG website at http://www.westconnect.com/planning_ccpg.php, and WestConnect

planning, see information on the WestConnect website at <http://www.westconnect.com>. The Regional planning process can be found on the WECC website at <http://www.wecc.biz>.

Regional Participation

The Transmission Provider will participate in the CCPG and WestConnect sub-regional planning processes. Participation in these sub-regional planning processes will ensure data and assumptions are consistent and properly represented in the respective sub-regional transmission plans.

The CCPG sub-regional plan will be coordinated with neighboring sub-regional entities (e.g., SWAT and Sierra) through WestConnect. WestConnect will coordinate sub-regional transmission plans between CCPG and SWAT participants into a single WestConnect Transmission Plan and submit the coordinated plan to WECC. The WECC process will coordinate the various sub-regional plans within the WECC region. The Transmission Provider will continue to provide its transmission system plan, data and assumptions to WECC regional committees¹ that are responsible for building databases. Regional committees use these data for database development, load and resource assessments, operating studies and planning studies.

The WECC Annual Study Program is conducted by the WECC System Review Work Group (“SRWG”). The SRWG is a working group under the WECC Transmission Studies Subcommittee (“TSS”), which provides input to and approves the study plan. The Transmission Provider is a member of, and actively participates in, the WECC TSS. The Annual Study Program analyzes multiple year, season and flow pattern scenarios to assess the reliability of the Western Interconnection. The results of these studies are presented to the WECC TSS for review and acceptance. The WECC SRWG also oversees the WECC base case development effort. These base cases are used in the Annual Study Program described above. The Transmission Provider actively participates in the review and updating of these base cases, ensuring that planned transmission facilities are included in the WECC regional analysis.

The Transmission Provider will participate in regional transmission economic planning studies through the WECC Transmission Expansion Planning Policy Committee (“TEPPC”), CCPG and WestConnect as outlined in the TEPPC Planning Protocol. The Transmission Provider will participate in TEPPC open meetings, as appropriate, to ensure that Transmission Provider high-priority study requests are included in the TEPPC study plan. The Transmission Provider will also review and comment, as appropriate, on any TEPPC study reports which show impacts on the Transmission Provider transmission system or include high-priority requests included in the study.

Transmission Provider and Sub-Regional Planning Process Differences

The Transmission Provider process will focus on developing a transmission plan to service its area loads whereas the CCPG and WestConnect sub-regional plan will focus on coordinating the

¹ For example: WECC System Review Work Group (SRWG) and WECC LRS Subcommittee.

integration of new generating facilities and evaluating transmission projects that move power around the bulk transmission system to serve load. The CCPG sub-regional planning process will rely on input from the transmission provider's plan and/or customer requests forwarded by the Transmission Provider for sub-regional plan evaluation. The sub-regional planning process use participating transmission owner staff to perform the needed study work.

The base case data used for local Transmission Provider planning will include input from CCPG entities to ensure that the base case data is coordinated. See Figure 3: Local, Sub-Regional and Regional Planning. In addition to using coordinated base cases for plan development, the resulting Transmission Provider transmission plan will be coordinated upward to CCPG and WestConnect.

Once the CCPG sub-regional plan studies are complete, the Transmission Provider will have an opportunity to review the plans. Since the Transmission Provider will participate in CCPG, the Transmission Provider will have opportunity to comment on the plan. Customers will have an opportunity for input into the sub-regional plan development by participating in the open CCPG meetings or can be kept informed of the sub-regional plan through participation in TCPC. The TCPC agenda may include a report on the sub-regional plan development.

The CCPG participants will develop the CCPG sub-regional transmission plan. The CCPG subregional plan will be forwarded to WestConnect for coordination with the SWAT and Sierra subregional plan. WestConnect will then submit the coordinated WestConnect Transmission Plan to WECC.

Simultaneous Plan Feasibility

The simultaneous feasibility of local, sub-regional and regional plans will be achieved in two ways. First, the Transmission Provider transmission plan will be coordinated with the CCPG sub-regional plan. The CCPG sub-regional plan will be coordinated with neighboring subregional plans through WestConnect. Finally, TEPPC will coordinate the various sub-regional plans and provide a central repository containing all sub-regional plans. Because these plans are vertically and horizontally coordinated, simultaneous feasibility will be known. Second, WECC also requires new project(s) with potential sub-regional or regional impacts to follow the WECC Regional Planning Process and the WECC Path Rating Process requirements. The WECC processes may proceed after the CCPG and WestConnect planning processes or be coincident to the CCPG and WestConnect planning processes. The WECC Overview of Policies / Procedures for Regional Planning Project Review Project Rating Review Progress Reports can be found on the WECC website at <http://www.wecc.biz>.

Principle 8 - Economic Planning Studies

FERC Order Requirement Summary

The Economic Planning Studies are studies provided to all parties with information on future transmission needs. These studies are separate from those performed for requests for

transmission service and generation interconnection. This Economic Planning Studies principle requires planning to address both reliability and economic considerations. Stakeholders are given the right to request a defined number of high priority studies annually to address congestion or integration of new resources or load. The rule does not obligate the Transmission Provider to fund economic projects and it does not “assign cost responsibility for those investments or otherwise determine whether they should be implemented”. The rule also requires customers, stakeholders and merchants to provide economic data.

Transmission Provider Actions

Economic studies will consists of studies of significant and recurring congestion and studies to consider whether transmission upgrades or other investment can reduce the overall costs of serving native load. Customers can choose the studies that are of greatest value to them.

Study Description

Economic planning studies are performed to identify significant and recurring congestion on the transmission system. Such studies may analyze any, or all, of the following: (1) the location and magnitude of the congestion, (2) possible remedies for the elimination of the congestion, in whole or in part, (3) the associated costs of congestion, and (4) the cost associated with relieving congestion through system enhancements (or other means). The Transmission Provider will perform, or cause to be performed, economic planning studies at the request of any transmission customer or stakeholder. Accepted requested economic planning studies will be performed by either the Transmission Provider or integrated into the appropriate sub-regional or regional study plan.

This principle embraces two types of studies – a study of significant and recurring congestion and a study to consider whether transmission upgrades or other investment can reduce the overall costs of serving native load. Collectively, these studies are called Economic Planning Studies. The Order allows customers to choose the studies that are of greatest value to them.

An Economic Planning Study differs from an Interconnect Study in several ways.

- *Economic Planning Study:* An Economic Planning Study is a transmission production cost study, which is not a system impact study or facilities study that is requested by a stakeholder. The study will result in (i) an overall non-binding high-level estimate of the estimated cost to increase transmission capacity for a request, and (ii) a value associated with this capacity based upon anticipated resource production cost savings to the extent that the requestor supplies adequate information to do so. The output of each completed study will be posted on the Transmission Provider OASIS website, and will not assign cost responsibility for identified investments or determine whether they should be implemented in any transmission plan.
- *Interconnection Study:* An Interconnection Study is a reliability study, which shall mean any of the following studies: the Interconnection Feasibility Study, the Interconnection System

Impact Study, and the Interconnection Facilities Study. The purpose of an Interconnection Study is to analyze the transmission system with the proposed facility to identify the transmission fixes, if any, that are required to maintain acceptable transmission system reliability performance with all lines in service and with one or more transmission or generation facilities out of service.

The Transmission Provider currently does not separately conduct economic planning studies and does not have the individual capability to conduct economic analyses, and thus, in the event of a request for an economic study, may contract with a qualified third party of its choosing to perform such work. The Transmission Provider will coordinate with the TCPC to identify and prioritize all Economic Study Requests and perform an assessment to determine if the Economic Study Request would reduce the overall cost of service to Native Load Customers and the load of other customers taking service under the Transmission Provider OATT.

High-Priority Study Requests

Stakeholders will have the right to submit a request in writing to the Transmission Provider asking to conduct a high-priority Economic Planning Study.

Requesting A High-Priority Economic Planning Study

A request for a high-priority economic planning study can be made by completing, signing and returning to the “Transmission Provider Economic Planning Study Request Form”. This economic planning study request form can be found in the “Transmission Planning” folder on Transmission Provider’s OASIS site. Processing requests will follow the procedure described in the “Transmission Provider Economic Planning Study Timeline and Process” section below.

The Transmission Provider reserves the right to request additional information, beyond that required in the original request form, if that information is needed to complete the study.

Valid Request

A valid request will be a request that supplies all the data in the Transmission Provider’s Economic Planning Study Request Form (i.e., Required Data). Requests that are not valid will follow the procedure described in the “Transmission Provider Economic Planning Study Timeline and Process” section below. The Transmission Provider will perform up to one High Priority Economic Study bi-annually.

Economic Planning Study Classification

Valid requests will be classified as either a Local Transmission Provider Economic Planning Study request or a Sub-Regional or Regional Economic Planning Study request. Sub-Regional or Regional Economic Planning Studies that are received by Transmission Provider will be forwarded to the appropriate sub-regional or regional entity for consideration.

A study request that is confined to the Transmission Provider's transmission system and does not affect the interconnected transmission system outside the Transmission Provider's transmission system will be classified as a Local Transmission Provider Economic Planning Study

Prioritizing Economic Study Requests

If more than one Economic Planning Study is requested, and if after considering clustering of all requests (described below) more than one distinct study remains, then the Transmission Provider will prioritize the studies identifying the highest priority study. It's important to note that the Transmission Provider in coordination with the TCPC may determine, after reviewing all valid requests, that no requests fit the requirements of an Economic Study and therefore no Economic Studies would be performed. These and other studies would be considered excess and would be classified as Additional Studies. The Transmission Provider will coordinate the prioritization in an open public process by consulting with the TCPC. Sponsors of the Economic Study Request are encouraged to attend the open TCPC meeting. The prioritization methodology will focus on the spirit of an economic study as stated by FERC. That is, "any such studies conducted pursuant to this principle ... would be for the purposes of planning for the alleviation of congestion through integration of new supply and demand resource into the regional transmission grid or expand the regional transmission grid in a manner that can benefit large numbers of customers, such as by evaluating transmission upgrades necessary to connect major new areas of generation resource (such as areas that support substantial wind generation). Specific requests for service would continue to be studied pursuant to existing pro forma OATT processes." Request that do not meet the spirit of this statement may not be studied.

The Transmission Provider may cluster Economic Study Requests in a manner that makes the study process efficient. Clustering will be determined by the location of the requests and whether or not there is a common or a potentially common transmission system problem addressed by the requests. Since the Transmission Provider transmission system is a relatively small system, groups of request with similar POR's and POD's would be good candidates for clustering. The Transmission Provider will consult with the TCPC in making clustering decisions and all information and data resulting from the study will be provided to CCPG, WestConnect or other regional entities.

If a request is submitted to move power into or out of the Transmission Provider's transmission system, or if the sub-regional transmission system is affected by the study request, then the request will be classified as a Sub-Regional or Regional Economic Planning Study and will be forwarded to CCPG, WestConnect or WECC TEPPC for inclusion into their study process.

Local Transmission Provider Economic Planning Study

Once a valid request is received and clustered, if appropriate, the Transmission Provider will proceed with the Local Transmission Provider Economic Planning Study or will forward the request or clustered economic planning study request to the appropriate sub-regional or regional entity. The Local Transmission Provider Economic Planning Study will be conducted, including appropriate sensitivity analysis, in a manner that is open and coordinated with the affected stakeholders and TCPC.

With respect to the Local Transmission Provider Economic Planning Study, the Transmission Provider will analyze and report on the location and magnitude of congestion, remedies or mitigation, cost of congestion and cost of relieving congestion. The location and magnitude of congestion will be made known through examination of historical data, past studies or through limited powerflow and transient stability study. To the extent hourly data is available and applicable to the request, the Transmission Provider will evaluate historical records to assess the historical duration and magnitude of congestion across the congested path. Once the Transmission Provider studies identify the location of future congestion, the Transmission Provider will obtain that paths historical hourly flows and extrapolate the flow data to the year when congestion occurs. Additional factors such as future load growth, generation, and transmission service needs are examples of adjustments that may be added to historical flows to make this assessment.

The Transmission Provider will define possible remedies or mitigation options that could relieve the congestion in whole or in part. The Transmission Provider transmission planning will likely need input from the customers making the request to define any non-transmission mitigation measures that could relieve the congestion in whole or in part. The robustness of the possible remedies may be affected by failure of customers to provide information. A plan will be considered acceptable only if it meets all reliability criteria.

The cost of congestion will be the most difficult for the Transmission Provider to evaluate since it does not have knowledge of generation dispatch costs or a step change to the customer's forecast loads unless the customer making the request provides the information. If the customer does not provide this data, the Transmission Provider will not be able to complete this portion of the economic study. The Transmission Provider will also require an economic dispatch model to perform the study and therefore will likely be required to consult this portion of the study request to sub-regional planning groups or the WECC.

Once the mitigation measures are identified, the Transmission Provider will be able to define the costs for transmission mitigation measures, but may need help from the customers making the request to define the costs of the non-transmission solutions.

The cost to conduct the one high priority Transmission Provider Economic Planning Study will be tracked and included in the Transmission Provider's next FERC filing for recovery as part of the overall pro forma OATT cost of service.

The LTP study (for retail load service) and the Economic Planning Study are separate studies as noted above. They examine the transmission system from different perspectives (reliability evaluation vs. economic evaluation). Even though these studies are separate, applicable study results from one study may be shared, recognized and evaluated in the other study.

Customer's Obligation To Share Data

The customer's obligation to share information is critical to completing an economic planning study. The Transmission Provider cannot be obligated to study the cost of congestion if it does not have the information to do so. Any customer requesting an economic study must supply all relevant information that it has in its possession for the study. If critical study information is

missing, the Transmission Provider will work with the customer to determine how the data can be obtained or estimated. If critical data cannot be obtained or estimated, the study cannot be completed. All confidential data will be protected by SOC and CEII concerns.

The Transmission Provider Obligation

This Principle does not require an economic planning study to be completed by the Transmission Provider or its agent unless requested by customers, nor does it obligate the Transmission Provider to fund economic projects, or to assign cost responsibility for investments nor to determine whether the investment should be implemented.

Transmission Provider Economic Planning Study Timeline and Process

The Transmission Provider Economic Planning Study will consist of a bi-annual study cycle with the following process steps:

- 1 Requests Received: Economic study requests will be received from customers during the fourth quarter of the planning cycle per the timeline posted on the OASIS.
 - 1.1 Requests that are not valid will be returned to customer for revision. Revised requests that are not returned to the Transmission Provider within 15 calendar days will be deemed withdrawn.
- 2 Cluster and Prioritize: The studies will be clustered, if appropriate, and prioritized during the first quarter.
 - 2.1 Studies will be classified as either a Transmission Provider Economic Planning Study or Sub-Regional (Regional) Economic Planning Study.
 - 2.2 Sub-Regional (Regional) Economic Planning Studies will be forwarded to the appropriate sub-regional group.
 - 2.3 Customers will be notified of their study request classification within 15 calendar days of that determination.
- 3 Study: the Transmission Provider will use reasonable efforts to complete the study within the annual study cycle.
 - 3.1 The Transmission Provider will establish a pre-study meeting or conference call with the customer and TCPC to discuss the details of the study.
 - 3.2 The progress of all Transmission Provider Economic Planning Studies will be discussed at the TCPC. The customer will be informed of the TCPC meeting and is encouraged to participate.
 - 3.3 If the study will not be completed within the annual study cycle, the Transmission Provider will inform the customer for the reason for the delay and an estimated time for completion.
- 4 The Transmission Provider will furnish the customer with a study report within 30 days of completion of the study.

- 5 The Transmission Provider will schedule a study results meeting within 30 days of the customer's receipt of the study report.
- 6 The report will be posted on Transmission Provider OASIS website under the Transmission Planning folder.
- 7 The Economic Planning Study result will be available for reference and appropriate consideration into the Transmission Provider Transmission System Planning Study.

Additional Economic Studies

Economic study requests that are not prioritized as the highest priority study will be considered Additional Studies. Sponsors of Additional Study requests will be given the option to pay for consulting services to complete the study or to withdraw the study. The sponsor may re-submit the economic study request for study consideration the next year's economic planning cycle. The process that will be followed for Additional Studies is discussed below.

If Transmission Provider Economic Planning Study will not be completed by yearend, the Transmission Provider will inform the requestor(s) in writing 30 days before the end of the year of the study delay, the reasons for the delay and an estimated completion date. The Transmission Provider will make reasonable efforts to complete the high priority study by yearend.

Process for Additional Economic Planning Studies

The following process will be followed for conducting an Additional Economic Planning Study.

1. Once the customer's economic study request has been determined to not be one of the highpriority study the Transmission Provider will notify the customer within 15 calendar days of that determination. The notification will also include an Additional Economic Planning Study Agreement.
2. Upon receipt of the Additional Economic Planning Study Agreement, the customer must sign and return the Agreement with a study deposit within 30 calendar days of receipt of the Additional Economic Planning Study Agreement.
 - The study deposit is \$75,000.
 - If the Transmission Provider does not receive the signed study agreement and deposit within 30 calendar days, the Economic Planning Study request will be deemed withdrawn.
3. The customer will be responsible for all actual costs to complete the economic planning study.
 - Actual costs less than the \$75,000 deposit will be refunded to the customer.

- The customer will be invoiced for actual study costs greater than the \$75,000 study deposit.
 - The customer must pay the invoiced amount within 30-calendar days of receipt.
4. Once the Transmission Provider receives the signed study agreement and deposit, the Transmission Provider will follow the Transmission Provider Economic Planning Study Process starting with step 3.

Principle 9 - Cost Allocation for New Projects

FERC Order Requirement Summary

The Cost Allocation for New Projects principle requires the planning process to address cost allocation for joint projects, economic projects, and projects that do not fit into existing OATT cost allocation principles. Examples of new projects requiring a cost allocation principle are projects involving several transmission owners or economic projects that are identified through the study process described in Principle 8 – Economic Planning Studies. The rule does not specify a particular allocation method, but the method should provide for fair allocation to beneficiaries, adequate incentives to construct transmission, and should have the support of state authorities and region-wide participants.

Projects Not Covered Under Existing Cost Allocation Rules

The following are examples of projects not covered under existing OATT cost allocation rules and would be affected by the cost allocation principle.

- A new project confined to the transmission system not for load service. For example, this project could move power across a future internal transmission constraint and be the result of a Local Transmission Provider Economic Planning Study. This project may have little or no regional impact, but would be a proactive approach to relieve future transmission congestion. WECC Regional Planning Process and Path Rating Process may be required, but subregional coordination would be required.
- A new project extending beyond the TP transmission system. A project identified in a regional economic planning study could be a major transmission line that has sub-regional or regional consequences. An example would be a new transmission line starting in the NE Wyoming area and ending in the Colorado area. This study would traverse a large geographic area and would impact the transmission systems of at least one other utility. This project would have sub-regional impacts and would require sub-regional coordination through CCPG, NTTG or WestConnect. The WECC Regional Planning Process and the Path Rating Process may also be required.
- A new project resulting from an Open Season Solicitation. This type of project could be a major transmission line that has sub-regional or regional consequences. An example would

be a new transmission line starting in Wyoming and terminating in Phoenix. This study would traverse a large geographic area and would impact the transmission systems of at least one other utility. A joint study would be required and would be facilitated by NTTG or WestConnect. This project could have sub-regional and regional impacts and would require sub-regional coordination through CCPG, WestConnect or NTTG. The WECC Regional Planning Process and the Path Rating Process would also need to be implemented.

Transmission Provider Allocation Methodology

For new projects that do not fit into the Transmission Provider OATT cost allocation principles, the TP will follow the “Local Transmission Provider Cost Allocation Methodology” located on the Transmission Providers OASIS unless a mutually agreeable cost allocation method can be reached between the TP and the project participants or sponsors. In developing alternative cost allocation methods, the TP will seek input from its stakeholders, through the TCPC. Cost allocation will be discussed and agreed to on a case-by-case basis with project participants or sponsors. It is possible that the cost allocation principles for economic projects will be different from the cost allocation methods for projects involving multiple owners.

The cost allocation developed from this methodology for a project falling outside the Transmission Provider OATT are not binding and are intended to represent an example of the cost allocation that could be agreed to by the sponsors of the study request. The actual cost allocation for a project will be determined once the project is committed to and the cost allocation is negotiated and agreed to by the committed project sponsors, which may be different than the study requestor. The actual cost allocation will be specified in the contract between the committed project sponsors.

There are various methods to assign costs for new projects within the Transmission Provider’s transmission system that do not have a regional impact and do not fall under the Transmission Provider OATT. One methodology is the principle based on cost-causation as shown in the “Local Transmission Provider Cost Allocation Methodology”. The costs that are allocated to customers are the costs for the system mitigation (i.e., upgrades, enhancements, etc.) that eliminate the unacceptable system performance. Through this principle, the customer whose request caused the problems is the customer that benefits most through the elimination of the problem and the quantification is based on the relative contribution to the problem being eliminated. Other methods for cost allocation include, but are not limited to, the following.

- An open season to determine ownership share;
- Open season for allocation of capacity without ownership; and •

Share prorated on MW use.

- Any of these methods may be the appropriate method for a particular situation

Sub-Regional and Regional Cost Allocation

The cost allocation for sub-regional or regional projects will be allocated based on the applicable sub-regional cost allocation policy or methodology (e.g., NTTG).

Recovery of Planning Costs

The TP will capture the planning costs using the traditional test period requirements in the next FERC tariff filing. No specific allocation to specific customers is contemplated.

The TCPC will provide input associated with other entities cost recovery needs for planning related activities.

Appendix 1

5. Transmission Coordination and Planning Committee Charter

I. Purpose

The Transmission Coordination and Planning Committee (“TCPC”) is a stand-alone advisory committee created to provide an open, coordinated, transparent forum whereby electric transmission stakeholders can comment and provide advice to the Transmission Provider (Transmission Provider) during the all stages of its transmission planning process. The TCPC will provide input in the development of the Transmission Providers’ Local Transmission Plan (LTP) and will:

- A. Be open to all interested stakeholders and allow open and transparent dialogue on all aspects of the transmission plan to the maximum extent allowed without violating Standards of Conduct (“SOC”) information or Critical Energy Infrastructure Information (“CEII”).
- B. Provide a forum for open and transparent communications among the Transmission Provider, transmission-providing neighbors, State authorities, transmission customers, and other stakeholders;
- C. Discuss all aspects of the Transmission Provider transmission planning activities including, but not limited to, methodology, study inputs and study results;
- D. Provide a forum for the Transmission Provider to understand better the specific electric transmission interests of stakeholders.

II. TCPC Membership

- A. TCPC membership will be open to any interested stakeholder.
- B. Members shall be subject to the following conditions:
 - 1. Agree to the Committee’s purpose and ground rules as described in this Charter; and
 - 2. Provide advice to the Transmission Provider as individual professionals; the advice they provide does not bind the Transmission Provider, agencies or organizations that the members serve.
 - 3. Execute a confidentiality agreement when necessary.
- C. Membership will be established through self-nomination. If the TCPC membership is either too small or too large, the Transmission Provider will work with the

committee to determine whether adjusting the size is appropriate and, if so, what mechanism should be used to accomplish the adjustment.

III. Decisions

- A. TCPC is not a decision making body, and it will not make decisions as a group.
- B. Discussion will be limited to Transmission Provider transmission planning issues and no other issues.

IV. Process

- A. TCPC meetings are open to all stakeholders to the maximum extent allowed without violating Standards of Conduct information and Critical Energy Infrastructure Information.
- B. TCPC will establish its meeting schedule as needed and will announce its meetings on no less than 10 business days prior to the meeting using the following methods;
 - 1. via email
 - 2. via postings on Transmission Provider OASIS prior to the meeting.
- C. The Transmission Provider or other designated party will facilitate and manage TCPC meetings and perform the following duties:
 - 1. Draft an agenda for each meeting, which shall be included in all meeting notices.
 - 2. Prepare a summary of all TCPC meetings for posting on the Transmission Provider OASIS.
 - 3. Conduct TCPC meetings that allow all members to have an opportunity to speak to all agenda topics in an open and transparent forum.

V. Member Responsibilities

- A. Each member agrees to attend (by phone or in person) and participate in TCPC meetings regularly.
- B. Each member agrees to listen carefully and respectfully to other members and to avoid interrupting other members.
- C. Each member agrees to respect the decision of any member to withdraw at any time for any reason.

VVI. Confidentiality

- A. TCPC members acknowledge that certain information may be protected as confidential information because of Standards Of Conduct (SOC) concerns (e.g., market sensitive data) or because it is classified as Critical Energy Infrastructure Information (CEII).
- B. Information not subject to SOC or CEII concerns will be posted on the Transmission Provider OASIS.
- C. Some (to be determined on a case by case basis) confidential information may be available to members through the Transmission Provider OASIS only if access rights have been provided by the Transmission Provider and a Confidentially Agreement has been signed.
- D. TCPC members agree not to discuss their committee activities or information obtained through the committee with the press.
- E. In discussing TCPC activities in public forums, members agree to discuss only their ideas, concerns, or positions regarding committee activities and information and not to characterize those of other members.

VII. Antitrust Policy

- A. The Antitrust Policy of the TCPC is as set forth below and shall be acknowledged at the beginning of every TCPC meeting.
- B. It is the policy of TCPC to fully comply with federal and state antitrust laws. Participants shall be mindful that an essential objective of TCPC is promoting or enhancing competition. Discussions in the following areas in particular can be very problematic and in some cases prohibited, and require careful attention for antitrust compliance:
 - your company's prices for products or services;
 - prices charged by your competitors;
 - allocating markets, Transmission Provider customers, or products;
 - limiting production; and
 - excluding dealings with other companies.

VII. Standards of Conduct Policy and Safeguards Policy

The membership of the TCPC includes individuals who are considered “Transmission Function Employees” or “Shared Employees” under the Standards of Conduct for the Transmission

Providers promulgated by the Federal Energy Regulatory Commission (“Standards of Conduct”). As “Transmission Function Employees” with access to non-public Transmission Information

have an obligation under the Standards of Conduct not to disclose it, unless they disclose such information to all interested parties via the OASIS. Additionally, Transmission Function employees are expressly prohibited under the Standards of Conduct from disclosing non-public

Transmission Information to its Energy or Marketing Affiliates. “Shared Employees” under the Standards of Conduct may have access or knowledge of non-public Transmission Information but may also work with the Energy or Marketing Affiliate of a the Transmission Provider.

However, “Shared” Employees are prohibited from disclosing non-public Transmission Information or acting as a conduit for information to flow from the Transmission Provider to its

Energy or Marketing Affiliates. To encourage transparency and compliance, the Transmission

Provider must post on the OASIS whenever joint meetings are scheduled between the Transmission Provider and its Energy and Marketing Affiliates under the terms of the Standards of Conduct. FERC has the authority to impose significant financial sanctions for violations of the Standards of Conduct. As such, it is the policy of the TCPC to conduct its business in a manner consistent with the Standards of Conduct.

Therefore, it is the policy of the TCPC to conduct its business in accordance with the following principles:

- At the outset of TCPC meetings the Standards of Conduct shall be acknowledged and participants shall be reminded of the obligations of Transmission Function Employees, Shared employees, and Marketing or Energy Affiliate Employees under the terms of the Standards of Conduct.
- If during the course of the TCPC’s work it becomes necessary for both a Transmission Provider and its Energy or Marketing Affiliate to participate in a joint meeting in the context of a TCPC meeting, it is the expectation of that the Transmission Provider will comport itself with the Standards of Conduct and any internal policy that may have been adopted by their respective organization implementing the Standards of Conduct.

Black Hills Energy Transmission System Planning Methodology, Criteria and Process Business Practice

BLACK HILLS/COLORADO ELECTRIC, LLC

**Transmission System Planning
Methodology, Criteria and Process Business
Practice**

April 8, 2010

Table of Contents

Introduction	3
TP Electric Transmission System	4
Process	4
TP Transmission System Planning Process	4
TP Transmission System Planning Methodology	6
Study Plan and Scenario Development	6
Technical Study	10
Decision	12
Reporting.....	13
Load Forecast Methodology	13
WECC Annual Study Program	14
Economic Planning Study	14
Criteria	15
Reliability Criteria	15
TP Internal Reliability Criteria	15
FERC Standard Requirements and WECC Reliability Criteria	17

Introduction

Black Hills/Colorado Electric, LLC (“BHCE”), referred to hereinafter as the “Transmission Provider” or “TP”, owns and operates certain transmission facilities with transmission service pursuant to a FERC-approved Open Access Transmission Tariff (“OATT”). The methodology, process and criteria described herein are used to evaluate the BHCE transmission system, ensuring system reliability is maintained throughout the planning horizon. Reliability, by definition, examines the adequacy and security of the electric transmission system.

The Federal Energy Regulatory Commission (FERC) Order No. 890 requires the TP to explain how they will treat retail native loads, in order to ensure that standards and processes are consistently applied to all customers. Consistent application of the TP planning process, standards, methodology and criteria for all customers (i.e., retail, network and point-to-point) is ensured through the coordination, openness and transparency of TP planning process. All customers are treated on an equal and comparable basis using the transmission system planning process, methodology and criteria described herein. All customer data is included in the planning analysis without regard to their classification. The TP transmission system planning process is designed to be transparent, open and understandable. The information described herein reflects existing practice, with the addition of new processes that encompass Order 890 transmission system planning requirements. For example, the TP planning process is being expanded to include input from stakeholders and other interested parties during the planning stage. As described in Attachment K to the OATT, a Transmission Coordination and Planning Committee (“TCPC”) will be established to facilitate a coordinated, open and transparent planning process.

FERC Order 890 makes a distinction between the transmission system planning for load due to customers’ needs (i.e., system planning) and planning for new generation interconnection. The TP adheres to the FERC Large Generation Interconnection Procedure (“LGIP”) and Small Generation Interconnection Procedure (“SGIP”) requirements to study generation interconnection requests. In studying a request for transmission service, the TP follows its tariff requirements as provided on the TP OASIS Website at <http://www.oatioasis.com/BHCT>.

Transmission Provider Electric Transmission System

The TP electric transmission system consists of approximately 194 miles of high voltage (115 kV) transmission lines located in southern Colorado. The transmission system generally follows the Arkansas River Valley from the Royal Gorge west of Canon City to the city of La Junta, Colorado.

Transmission Provider Planning Process

The Local Transmission Plan (“LTP”) study process is depicted in the following flowchart.

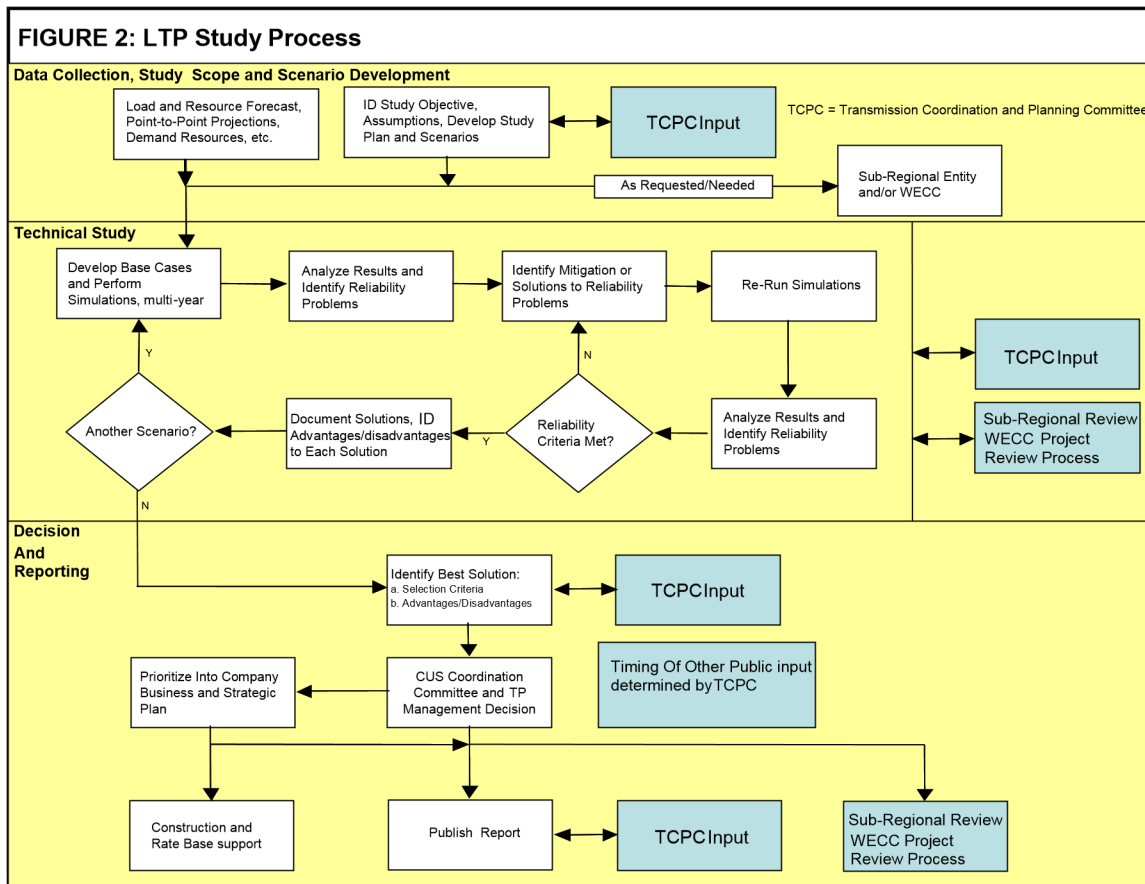

The TP will follow a four (4) quarter study cycle that follows the process shown in Figure 2 above. This process will be used to develop a 10-year LTP. The planning process steps (i.e., Data Collection, Study Scope and Scenario Development, Technical Study, Decision and Reporting) are fully integrated and produce the LTP. This process is fully described in the following sections.

1. Timeline

The typical timeline for the LTP study cycle is shown in the following table. The Transmission Coordination and Planning Committee³ (“TCPC”) will meet quarterly to provide input throughout the LTP study process.

Quarter	Planning Steps	Data Collection	TCPC Meetings
Q4	Study Scope & Scenario Development	Open	X
Q1	Technical Study	Optional	X
Q2		Closed	X
Q3	Decision & Reporting		

This timeline displays the approximate time dedicated to each of the planning steps and when forecast data will be collected. Data that is collected will fall into one of three time periods for inclusion into the TP planning process - “Open”, “Optional” or “Closed”. All data collected during the Open time period will be included in the study assuming the data is complete. Data obtained during the Optional time period may or may not be included in the study if it is not complete or the Technical Study has progressed to a point where including this information is not practical. The TP will consult with the TCPC in making this determination. Data collected during the Closed time period of the annual cycle will be compared to the data used in the technical analysis and any notable changes will be discussed in the final LTP report.

³ TCPC is a stakeholder committee that meets regularly with the TP to provided input and comments throughout the LTP study cycle. Membership is open and communication is open and transparent. For more information see Attachment K to the OATT on the TP OASIS Website <http://www.oatioasis.com/BHCT/>.

2. Regional & Sub Regional Participation

The TP's participation in regional and sub-regional planning activities will be broad, ranging from providing data to participating in studies and committees. The TP transmission system data, assumptions and LTP will be shared with interconnected transmission systems, sub-regional and regional entities. The TP base case data and LTP will be provided to other Transmission Providers when appropriate.

The TP will provide its LTP study data and assumptions to sub-regional and regional committees⁴ that are responsible for building databases and then using these databases for load and resource assessments or for operating and planning reliability studies. This is an annual process that requires the TP to provide basic transmission data, load forecasts and generation dispatch information to be shared and included in the databases used by regional and sub-regional planning entities. The TP will participate in these forums as appropriate.

The TP will provide its LTP to the WECC, Colorado Coordinated Planning Group ("CCPG"), WestConnect and other sub-regional entities as appropriate. In the subregional context, the TP is an active participant of CCPG and WestConnect. The TP will submit its data, assumptions and LTP to CCPG and WestConnect as required for inclusion in all applicable sub-regional transmission plans. The TP will actively participate in the CCPG and WestConnect planning process to ensure data and assumptions are properly represented in all applicable sub-regional plans. When appropriate the TP will provide its LTP to WECC or other regional entities.

The TP may participate in sub-regional and regional transmission planning studies as appropriate to ensure data and assumptions are coordinated. These studies may be focused on integrating new transmission lines into the regional transmission network or a broad planning study of regional or sub-regional transmission needs. The TP's participation in these studies will be guided by the intent of the study and how the TP transmission system might be affected.

Transmission Planning Process and Basic Methodology

Below is a discussion of the TP's LTP study process and basic methodology that is used to formally analyze the Common Use System. By application of this methodology, the TP ensures that a reliable transmission system exists to serve network customer load and firm point-to-point transmission service obligations. The TP's methodology is intended to define operating conditions that fail to meet reliability criteria and then identify mitigations or solutions (e.g., transmission and non-transmission⁵) that mitigate any criteria violations. The operating conditions are for a specific instant in time, such as peak load conditions, and are not an integrated time period, such as an hour, day, month, etc. The TP's basic process and methodology described below is focused on transmission reliability and not economic studies that can be requested by stakeholders.

⁴ For example: WECC System Review Work Group (SRWG), WECC LRS Subcommittee, WECC Technical Studies Subcommittee, Colorado Coordinated Planning Group, etc.

⁵ Demand-side resource, generation, interruptible load, etc.

The TP's goal is to design a reliable, least cost transmission system that will perform under expected system conditions wherein customer load can be served reliably throughout the planning horizon.

3. LTP Study Process

The TP planning process includes the three steps: (1) Data Collection, Study Scope and Scenario Development, (2) Technical Study, (3) Decision and Reporting. How these steps are integrated to formulate the LTP is shown in Figure 2 above and further described below. The transmission lines monitored in the LTP study may range in base voltage and may be operated in either a networked or radial configuration.

The LTP study process involves modeling forecasted customer demand, identifying area reliability criteria violations, evaluating possible violation mitigation options and selecting solutions that meet the BHCE transmission system reliability needs. The LTP study evaluates the transmission system reliability using a 10-year planning horizon. The planning effort will consider transmission and non-transmission alternatives to resolve any reliability criteria violations within the BHCE transmission system. The TP's process is flexible, involves stakeholder input and is intended to develop an LTP that:

- Responds to customers needs;
- Is low cost (e.g., Total Present Value Revenue Requirement, Rate Impact, etc.);
- Considers non-transmission and transmission alternatives;
- Assesses future uncertainty and risk;
- Promotes the TP commitment to protecting the environment;
- Includes input from the public and other interested parties;
- Provides adequate return to investors;
- Complements corporate goals and commitments;
- Meets all FERC and WECC Standards;
- Meets all applicable state regulatory expectations;
- Meets regional and sub-regional planning requirements;
- Satisfies all requirements of FERC Order 890; and
- Conforms to applicable state and national laws and regulations.

Data Collection, Study Scope and Scenario Development

This first phase of the LTP study process, as can be seen in Figure 2 above, requires coordination and input from the TCPC. The TP will work with the TCPC to review noncommercially sensitive data collected, as well as identify the study scope and pertinent scenarios that should be studied in order to meet stakeholder needs. The TCPC will provide input into the TP transmission planning process pursuant to FERC Order 890 Transparency requirements. Information regarding the TCPC can be found in Attachment K to the Transmission Provider OATT located on the BHCT OASIS Website at <http://www.oatioasis.com/BHCT/>.

▪ ***Data Collection***

Up-to-date and accurate input data is critical for producing meaningful results from any planning study. To this end, the TP will request the following data from all Transmission Customers during the first phase of the LTP study process:

Historical Load Data: Monthly energy, peak load data for the prior calendar year. Monthly energy, peak load data for the current year as it becomes available.

Load Forecast Data: Ten (10) year monthly energy, peak load and resource and minimum load and resource forecast. Ten (10) year annual energy, peak load and resource and minimum load and resource forecast.

Point-to-Point and other Transmission Customers: Ten (10) year forecast of projected use or rollover of existing reservations. Additionally, any expected additional reservations should be provided. All forecasts shall specify a Point of Receipt and Point of Delivery by bus.

Generation Forecast Data: Technical engineering data for all generators and interconnection facilities, peak capabilities (MW/MVAR) and maintenance cycle.

Demand Response, Demand Reduction, Conservation, DSM: Ten (10) year projected load reduction or alteration due to the listed initiatives.

Interruptible and Other Load: Peak load forecast with and without the interruptible portion of the forecast data applied.

Other Supply Sources: Monthly energy, peak load data for electrical supply sources not from generators.

A request for this data will be sent by the TP to all Transmission Customers no later than close of business Friday of the second full week of January. The data will request will specify the date that all data is due to the TP. The data will be submitted via an Excel workbook which will be posted on the TP OASIS website, along with instructions regarding the submittal of data as well as the data format.

▪ ***Study Scope and Scenario Development***

The TP uses scenario planning and not probabilistic planning for developing the electric transmission system plan. The TP may, however, use probabilistic assessment methods within a defined scenario to evaluate uncertainty

A scenario represents a “snapshot” in time that depicts a specific condition, for example: peak summer load, minimum area generation, maximum import, etc. Each scenario should be realistic and be designed to provide maximum stress to the transmission system regardless if it causes inadequate transmission system performance as measured against established criteria. Since a large number of combinations of load, generation and export/import conditions exist, careful

consideration must be given to design each scenario to depict a future load and generation dispatch pattern that stresses the transmission system. Experience has shown that the BHCE transmission system is stressed during heavy summer conditions with minimum exports and during light load conditions with maximum export conditions. A good study plan and realistic scenarios will help ensure the LTP identifies upgrades which will ensure the transmission system remains reliable under all operating conditions.

The TP basic methodology is to develop the base scenarios to study and then to develop uncertainty scenarios from these base scenarios. This methodology is described in more detail below.

▪ ***Base Case Scenarios***

Base case scenarios will be used to examine the transmission system under a variety of future assumptions for a specific period of time. Varying the amount, type and location of generation, the load level and export/import conditions are all important in defining a scenario. These assumptions include, but are not limited to the following:

- Load Forecast (e.g., year to study)
- Load Condition to Study (e.g. season, peak load or light load, etc.)
- Generation Available (e.g., generation additions/changes)
- Generation Dispatch Conditions (e.g., how is the generation operated)
 - Different types of generation to determine how generation responds to outage conditions
 - Generation location and magnitude to determine transmission stress
 - Higher generation levels to cause more power to be exported out of the TP transmission system. Lower generation levels with high imports
- Transmission System Configuration (e.g., what elements are out-of-service)

Even though new generation interconnection projects follow the OATT LGIP/SGIP, the study results from generator interconnection projects cannot be ignored in the LTP study. The addition of new generation to the BHCE transmission system can affect the flows throughout the system. Additional power flows from the new generation, and flow changes due to transmission system upgrades, may require additional transmission system upgrades. The TP, with input from the TCPC, will consider scenarios including queued generator interconnection projects with associated transmission facilities or develop uncertainty scenarios which include these projects.

▪ ***Uncertainty Scenarios***

The uncertainty scenarios are intended to recognize that the future, as assumed in the base case scenarios, is not known. This uncertain future creates risk, which may be quantifiable or non-quantifiable. Risk may be expressed as a dollar cost or other impact. The base scenarios must make assumptions about future conditions, but the uncertainty scenario helps with understanding the risk associated with those assumptions. The purpose of any uncertainty scenario is to develop

information about the cost and electrical performance associated with that scenario so that an informed decision about future transmission investments, and the associated risks, can be made.

Technical Study

The technical study is the second phase in the LTP study process. The technical study will begin by developing base cases which reflect the base case scenarios identified in the first phase. This may require developing several base cases to span the 10-year planning study horizon. For example, to study summer peak conditions in the years 2010 and 2015, two distinct base cases that reflect the load, generation and transmission facility changes and/or additions for the specific year would be required. Developing a base case accurately depicting the base case scenario is critical and can take a significant amount of work and time to develop.

Once the base cases have been developed, the technical study is performed to examine the reliability of the CUS to meet the forecasted load and transfers. The TP uses a sophisticated computer model (i.e., Siemens PTI PSS/E) to simulate generator output, transmission line flows, electrical equipment operation, customer loads and power transfers. The technical study quantifies transmission system performance by measuring the bus voltage, equipment loading, reactive power requirements, system frequency and other electrical parameters and comparing them against established reliability criteria. If inadequate performance is observed, a solution or mitigation (e.g., transmission or nontransmission) is proposed, and the base case is modified to include the proposed solution. The simulation is repeated and system performance is again measured against established criteria. This circular process is repeated until the system performance meets or exceeds reliability requirements. It should be noted, that at the conclusion of the study, only a single solution will be defined and implemented, so once a solution is defined for a scenario, it must be included in all scenarios to ensure that it does not cause negative impacts under all conditions.

A model is developed that includes technical data for generation, transmission lines, electrical system equipment and customer load levels and geographic distribution. The basic methodologies for developing the base case data are described below.

- **Transmission:** The TP will use the existing transmission infrastructure as a starting point. This data will be reviewed and any updates to the existing transmission data will be coordinated with the TCPC and included in the base case. Any transmission facilities under construction will be included in the base case. Proposed transmission additions not under construction will not be included in the initial base case unless both the TP and the TCPC agree that they should be included. These projects may be included in one or more uncertainty scenarios.

New regional transmission projects that affect the BHCE transmission system will be included if the project is in Phase 2 of the WECC Three Phase Rating Process and both the TP and the TCPC agree that it should be included. These projects may be included in one or more uncertainty scenario if they are not included in a base case.

- **Generation:** The TP will use the existing interconnected generation as a starting point. The generation data collected in the first phase will be reviewed and any updates or changes will be coordinated with the TCPC and included in the base case. Queued generation projects may be included, along with any associated transmission additions and upgrades, upon agreement of both the TP and TCPC. Queued generation projects may be included in one or more uncertainty scenarios.
- **Demand Response Resources:** The TP will review the demand response resource forecasts obtained in the first phase with the TCPC for inclusion in the base case. One or more uncertainty scenarios may analyze adjustments to the provided forecasts.

The technical analyses will use different engineering studies to evaluate the system performance. These studies are designed to use different engineering perspectives to ensure system reliability is maintained. These methods include, but are not limited to, the following:

- Steady-State Powerflow Analyses
- Post Transient Steady-State Powerflow Analyses (or Steady-State Post Fault Analysis)
- Transient Stability Analyses (or Dynamic Analyses)
- Fault Duty Analyses
- Reactive Margin Analyses

A study of the transmission system under static conditions is a steady-state power flow study, and a study over time⁶ is called a transient stability study. The steady state power flow analysis is a static evaluation of a local area transmission system that examines the transmission system under normal operating conditions with all lines in-service and with single and multiple transmission lines or elements out-of-service (i.e., N-1, N-2, N-1-1, etc. conditions). Note that the “-1” in N-1 represents the number of transmission elements that are out of service. A transient stability study (i.e., a dynamic simulation study) evaluates the transmission system performance on a progressive time dependent basis. These studies evaluate credible outage events to determine if the transmission system will recover to acceptable steady-state operation after the outage. The studies include an assortment of outage events that are intended to provide a thorough test of the reliability of the transmission system. After a power flow simulation is completed, a search of the simulation results for unacceptable thermal overloads and voltage excursions is made. Unacceptable transmission system performance must be corrected by including transmission and non-transmission (e.g., demand-side resource, generation, etc.) fixes into a second simulation. Additional mitigation or fixes are included in the simulation until a valid solution is found. A valid solution is one that meets the reliability criteria describe below. System performance

⁶ The Siemens PTI PSS/E program completes a transient stability study by running the computer model repeatedly over time and recording how the generation and transmission elements change over time as the result of an outage. A sequence of results is produced that depict how the generation and transmission system equipment responds to this outage condition. The time step must be very small to accurately capture transmission system changes because generation and load are matched instantaneously. For example, a dynamic study runs a powerflow simulation of the system, with progressive “real” time adjustments, every ¼ cycle or 0.00417 seconds. Thus to make a 5 second study, the program must be run 1200 times.

information for this scenario is identified and retained for comparative analysis between scenarios during the decision step.

The credible “worst case” single and multiple fault events must be simulated to determine if the transmission system will recover to acceptable steady-state operation. A dynamic simulation includes an assortment of outage events that are intended to provide a thorough test of the reliability of the transmission system.

From these studies the changes in system steady-state and transient voltage levels after the loss of a single line, multiple lines, or generating units; changes in the line and equipment thermal loading conditions; changes in Volt-Ampere reactive (“VAR”) requirements (voltage support); and unacceptable frequency excursions are evaluated. All relevant reliability criteria are applied in these evaluations. Reliability criteria are defined in the Reliability Criteria section of this document. Any violations of reliability criteria are noted and will require mitigation.

The TP will also conduct fault duty and reactive margin studies as needed. A fault duty study is a study of electrical current interrupting devices (e.g., breakers) to ensure the device can open under maximum load conditions. When a fault or short circuit occurs on a power line, the protective relay equipment detects the increased current (i.e., fault current) flowing in the line and signals the line’s circuit breakers to open. When the circuit breakers open, they must be capable of interrupting the full fault current. The worst-case fault current is commonly referred to as the “fault-duty”. A reactive margin study is a study to ensure that the transmission system has sufficient voltage control to maintain adequate voltage levels.

Decision

An objective of a system planning study is to evaluate the range of potential transmission and non-transmission (e.g., demand side management, generation, conservation, etc.) solutions within the technical study and determine the best solution. The primary purpose of the decision phase is to provide descriptive information about the system and the problem (risk, cost, etc.) and identify the best solution or mitigation to resolve the problem. The TP will use selection criteria and weighting to provide a ranking of the solution(s). The TP will seek input from the TCPC in identifying and weighting the criteria to use in selecting the appropriate solution. This information along with documented advantages and disadvantages of each solution will be used to aid in selecting best solution or mitigation that achieves the objectives of the transmission plan. Selection criteria may include, but is not limited to, the following:

- Total present value of upgrade costs
- Time available to implement upgrade
- System performance with each solution
- Probability of scenario requiring a solution
- Environmental assessment and/or costs

- Non-quantifiable assessment

The primary purpose of the selection criteria is to provide descriptive information (e.g., costs, risks, etc.) about the system and solution(s) needed to resolve the problems. This information can be ordered or weighted so that stakeholders can understand the differences between the scenarios and provide input to the TP. TP management can then use this information to make an informed decision regarding future transmission investment to serve future network load and point-to-point requests. Once approved, the solution will be prioritized into the TP Business and Strategic Plans.

Reporting

The TP, with input from the TCPC, will develop the LTP which will describe the study plan, scenarios, technical studies, selection criteria and selected solutions. The final LTP will be published on the TP OASIS web page.

Load Forecast Methodology

Pursuant to FERC MOD-016, the TP will obtain load forecasts from Load Serving Entities (“LSE”) within the TP. A summer and winter peak load forecast will be collected from the LSE’s within the TP for use in the study. Additionally, the TP will request a minimum load forecast for use in light load scenarios. The LSE’s load forecasts will be summed, assuming they are time coincident, to calculate the TP area load forecast. The loads within the TP are metered and tracked. That is, the loads are well defined and monitored. If the LSE and TP load forecast, based on actual historical loads, results are significantly different, the TP will attempt to reconcile these differences. If the TP cannot reconcile these differences, the TP will choose which forecast to use in the study.

The TP area load forecast will be adjusted to reflect demand response resource reductions, conservation reductions and other appropriate peak load modifying sources.

Once the TP area load forecast is developed, this forecast is disaggregated to the respective transmission system load buses. There are two types of load buses – (1) a load bus where the load does not change over time (e.g., a single large industrial load bus); and (2) a load bus where the load changes over time (e.g., residential load). The TP will use its knowledge of load characteristics along with historical loading observations to estimate the individual load bus data in time. The load bus forecasts are summed and compared to the TP load forecast. If the two forecasts do not match, the TP will adjust the variable bus load forecasts until the two forecasts match.

WECC Annual Study Program

In addition to the TP’s own LTP study, the TP participates in the WECC Annual Study Program. This program examines the reliability of electric transmission lines that are instrumental in moving electricity across the TP system from sources of supply inside and outside the TP system

to markets inside and outside the TP system. A detailed simulation model⁷ is used for steady state and dynamic event analysis that assesses electric transmission stability before and after a loss of a critical electrical element (e.g., transmission line).

Two types of study assessments are conducted - Operating Transfer Capability (“OTC”) studies and Bulk System Planning Studies. The distinction between these studies is that the OTC study establishes the next season’s maximum transfer capacity for selected electric transmission paths and the planning studies evaluate the bulk transmission system’s adequacy and security 2-10 years into the future. The Annual Study Program requires that each year approximately ten detailed studies be conducted to assess bulk electric transmission reliability. The mix of operating and planning studies varies each year.

If conducting a seasonal OTC study, the TP will follow the WECC policy outlining the process, procedures and assumptions to use for OTC studies. OTC studies are only required on WECC Rated Paths. The TP does not currently operate a qualified WECC rated path.

The Bulk System Planning Study originates through the WECC System Review Work Group (“SRWG”) annual planning program. The WECC study follows the same process as the OTC studies, except the season can range from 2 to 10 years in the future and may include proposed new facilities. The goal of the planning study is to examine the reliability of the future transmission system under prescribed seasonal loads, generation patterns, and various outage conditions and to identify appropriate upgrades and/or new facilities to maintain bulk system reliability into the future.

Economic Planning Study

Pursuant to FERC Order 890, stakeholders may request an Economic Planning Study. The purpose of FERC Order 890 Economic Planning Studies is to ensure that customers may request studies that evaluate potential upgrades or other investments that could reduce congestion or integrate new resources and loads on an aggregated or regional basis (e.g., wind developers), not to assign cost responsibility for those investments or otherwise determine whether they should be implemented. This is different than a proposed new generation interconnect study in that an interconnect study is to interconnect a new Generating Facility, or to increase the capacity of, or make a Material Modification to the operating characteristics of, an existing Generating Facility that is interconnected with the TP’s transmission system.

A request for an Economic Planning Study will use the methodology and process as outlined in Attachment K of the OATT.

⁷ The TPs model the WECC transmission system using the Siemens PTI PSS/E software. The TP base case data includes 69 kV and 230 kV transmission system data.

Criteria

The TP reliability criteria, NERC/WECC⁸ regional reliability criteria (hereafter called Reliability Standards), FERC⁹ Standards and industry standards (e.g., IEEE Standards) are the basis for the TP transmission planning criteria. This section describes these criteria.

4. Reliability Criteria

Electric transmission reliability is concerned with the adequacy and security of the electric transmission system. Adequacy addresses whether or not there is enough transmission capacity, and security is the ability of the transmission system to withstand contingencies (i.e., the loss of a single or multiple transmission elements). The TP uses two types of reliability criteria as shown below:

- TP Internal Reliability Criteria. A set of technical reliability measures that have been established for the safe and reliable operation of the CUS.
- FERC Standards and WECC Reliability Criteria. A set of minimum performance standards for system performance following a credible outage event on the transmission system.

The TP uses these criteria in evaluating the need for a modification or addition to transmission facilities and/or a modification to, or addition of generating facilities. The TP will use these reliability criteria as needed to fully evaluate the impacts of transmission facilities, generating facilities or loads on the BHCE transmission system. The TP may augment these criteria with other standards such as, but not limited to, the ANSI and IEEE standards.

The TP planning process ensures that changes which either directly or indirectly affect the BHCE transmission system will not materially reduce the reliability to existing customers. The BHCE transmission system must provide reliable high quality service to all customers.

Internal Reliability Criteria

The TP Internal Reliability criteria are used for reliability performance evaluation of the electric transmission system. Steady-state implies the condition on the transmission system before an outage, or after an outage and after switching occurs, regulators adjust, reactors or capacitors to switch, and generation stabilizes (typically three minutes or more). This latter condition is also called post-fault reliability requirements.

These criteria support the FERC Standards and WECC Reliability Criteria that disallow a blackout, voltage collapse, or cascading outages unless the initiating disturbance and corresponding impacts are confined to either a local network or a radial system. An individual project or customer load may require an enhanced reliability requirement.

⁸ WECC is in the process of removing standards that duplicate the FERC Standards; so only the more stringent WECC criteria will remain.

⁹ The FERC Standards are implemented by NERC.

The TP plans that the BHCE transmission system to provide acceptable voltage levels during system normal and outage conditions. Areas of the BHCE transmission system that are served by radial transmission service are excluded from single contingency evaluation.

▪ ***Steady State, Transient and Post-Transient Voltage Criteria***

The TP follows the voltage limits as outlined in the Colorado Coordinated Planning Group’s Voltage Coordination Guide (“VCG”).

- The VCG defines “Acceptable Voltages” as between the range of 0.95 to 1.05 per unit. “Acceptable Voltages” are used by the TP as the steady state voltage criteria. This criteria is based on the assumption that all switching has taken place, all generators and transformer Load Tap Changer’s (“LTC”) have regulated voltages to set values, and capacitors or reactors are switched.
- Transient voltage criteria require that the first-swing voltage at all buses shall not exceed 0.70 per unit.
 - The VCG defines “Emergency Voltages” as in the range 0.9 to 0.95 and 1.05 to 1.10 per unit. “Emergency Voltages” are used by the TP as the post fault voltage criteria. This criteria is based on the assumption that only automatically adjusting equipment has operated, such as generator excitation systems, automatic LTC’s, automatically switched reactors and capacitors.

Transmission Equipment Rating and Loading

Transmission facility ratings are determined by BHCE’s Facility Ratings Methodologies.

▪ ***Facility Connection Requirements***

Each Transmission Owner is required per NERC Reliability Standard FAC-001-0 to have documented facility connection requirements. These documents dictate the specific requirements for connecting new facilities to the BHCE transmission system.

▪ ***Remedial Action Scheme (RAS) and Overload Mitigation Scheme (OMS) Application***

The TP may consider a RAS or an OMS application to protect the CUS against certain types of events, but each application will be evaluated on a case-by-case basis with no assurance that a RAS or an OMS application will be acceptable.

- An OMS may be used to mitigate a thermal overload that is less than the thermal rating of a system element by tripping or by generator run-back. This may be an appropriate application for an overload that results from a single (or multiple) contingency outage event. The OMS may be manual (with a response time not greater than 30 minutes) or automated (with a faster response time). Typically,

response time for an OMS application is measured in tenths of seconds to minutes. Generally, an OMS can be thought of as a scheme that can be backed up by relay operation or operator intervention if necessary. An OMS will not be considered as acceptable mitigation for system element overload if its failure to operate properly could lead to widespread outages on the Bulk Electric System.

- A RAS may be used for certain single and multiple contingency outage events that result in unacceptable electric system reliability performance that is not related to minor thermal overloading and that requires a more immediate response (e.g., unacceptable transient stability performance). A RAS must be an automated response to the outage. Typically, response time for a RAS application is measured in cycles or at most a few seconds. While the ranges of expected response times may overlap, there is a distinctly different character to a RAS. It may be expected to meet a higher reliability standard, depending on the application. There is no expectation that a transmission system operator could intervene if the RAS were to fail to operate. Any RAS application must meet WECC system planning criteria. The TP will submit any RAS application that may be proposed to the WECC RASRS for their approval if the RAS failure could lead to widespread outages on the Bulk Electric System of the Western Interconnection. If a RAS does not receive the approval of the RASRS, the TP will not use it.

- ***Voltage Ride Through***

The TP will follow FERC and WECC voltage ride through criteria as appropriate. Under certain circumstances, the TP may require the generation to trip offline to maintain system reliability instead of riding through the event.

NERC Reliability Standard Requirements and WECC Reliability Criteria

The NERC Reliability Standards and the WECC Reliability Criteria are used to evaluate the system performance under steady state and transient stability and the recovery performance of the BHCE transmission system.

Black Hills Energy Available Transfer Capability Implementation Document (ATCID)

 BLACK HILLS CORPORATION COMPANY POLICY		
Affected Business Unit(s): Black Hills Power, Inc. Cheyenne Light Fuel Power Company Black Hills Colorado Electric, LLC	Originating Department(s): FERC Tariff & Contracts	
	Effective Date: 12/05/2023	
Procedure No.: NERC-001.1 MOD-001 ATCID	Revision Date: 12/04/2023	Rev 2.2
MOD-001 ATC ID		

1. Background

MOD-001-1a is utilized to ensure that calculations are performed by Transmission Service Providers to maintain awareness of available transmission system capability and future flows on their own systems as well as those of their neighbors.

2. Purpose

This Available Transfer Capability Implementation Document (ATCID) provides documentation of required information as specified in the NERC Standard MOD Standards and the NAESB OASIS Standards regarding the calculation methodology and information sharing of Available Transfer Capability specific to this Transmission Provider.

3. Definitions

3.1 Terms used in this document align with the definitions identified in the NERC Glossary of Terms and the NERC MOD Standards.

3.2 Specific terms to this Transmission Provider are as listed:

3.2.1 Available Transfer Capability (ATC) – A measure of the transfer capability remaining in the physical transmission network for further commercial activity over and above already committed uses.

3.2.2 Capacity Benefit Margin (CBM) – The amount of firm transmission transfer capability preserved by the transmission provider for Load-Serving Entities (LSE), whose loads are located on that Transmission Service Provider’s system, to enable access by the LSEs to generations from interconnected systems to meet generation reliability requirements. The transmission transfer capability preserved as CBM is intended to be used by the LSE only in times of emergency generation deficiencies.

3.2.3 Counterflow – A variable component of the Transmission Provider’s selected ATC calculation methodology that impacts ATC in a direction counter to prevailing TTC rating.

3.2.4 Existing Transmission Commitments (ETC) – Committed uses of a Transmission Service Provider’s Transmission system considered when determining ATC.

$$ETC_F = NL_F + NITS_F + GF_F + PTP_F + ROR_F + OS_F \text{ (MOD-029, R5)}$$

$$ETC_{NF} = NITS_{NF} + GF_{NF} + PTP_{NF} + OS_{NF} \text{ (MOD-029, R6)}$$

- 3.2.5** $GF_{F,NF}$ – is the firm capacity set aside for grandfathered Transmission Service and contracts for energy and/or Transmission Service, where executed prior to the effective date of a Transmission Service Provider’s Open Access Transmission Tariff or “safe harbor tariff.”
- 3.2.6** $NL_{F,NF}$ – is the firm capacity set aside to serve peak Native Load forecast commitments for the time period being calculated, to include losses, and Native Load growth, not otherwise included in Transmission Reliability Margin or Capacity Benefit Margin.
- 3.2.7** $NITS_{F,NF}$ – is the non-firm capacity set aside for Network Integration Transmission Service serving Load (i.e., secondary service), to include losses, and load growth not otherwise included in Transmission Reliability Margin or Capacity Benefit Margin.
- 3.2.8** $OS_{F,NF}$ – is the non-firm capacity reserved for any other service(s), contract(s), or agreement(s) not specified above using non-firm transmission service as specified in the ATCID.
- 3.2.9** $PTP_{F,NF}$ – is non-firm capacity reserved for confirmed Point-to-Point Transmission Service.
- 3.2.10** ROR_F – is the firm capacity reserved for Roll-over rights for contracts granting Transmission Customers the right of first refusal to take or continue to take Transmission Service when the Transmission Customer’s Transmission Service contract expires or is eligible for renewal.
- 3.2.11** **Transmission Reliability Margin (TRM)** – The amount of transmission transfer capability necessary to provide reasonable assurance that the interconnected transmission network will be secure. TRM accounts for the inherent uncertainty in system conditions and the need for operating flexibility to ensure reliable system operation as system conditions change.
- 3.2.12** **Total Transfer Capability (TTC)** – The amount of electric power that can be moved or transferred reliably from one area to another area of the interconnected transmission systems by way of all transmission lines (or paths) between those areas under specified system conditions.

4. Available Transfer Capability (ATC) Methodology (MOD-001, R1)

Black Hills Corporation (BHC) has selected the MOD-029 (Rated System Path Methodology) for determining Total Transfer Capability and Available Transfer Capability for all posted paths and in all ATC time horizons.

5. ATC Calculation Frequency of Recalculation

5.1 Calculation and Recalculation of Hourly Values (MOD-001, R2.1, R8.1)

BHC calculates and posts to its OASIS hourly ATC values once per hour and recalculates for each ATC path at a minimum for the next 168 hours.

5.2 Calculation and Recalculation of Daily Values (MOD-001, R2.2, R8.2)

BHC calculates daily ATC values once per day for each ATC path at a minimum for the next 31 calendar days. Transmission outage information is incorporated into the hourly ATC values.

5.3 Calculation and Recalculation of Monthly Values (MOD-001, R2.3, R8.3)

BHC calculates monthly ATC for each ATC path at a minimum for the next twelve (12) months. ATC values are recalculated with the following frequency:

- Hourly, at least once per hour
- Daily, at least once per day

6. Required Available Transfer Capability Implementation Information

6.1 Implementation of MOD-029 (MOD-001, R3.1 / MOD-029, R7, R8)

BHC implements the firm and non-firm calculations as reflected in MOD-029. The input parameters to the ATC calculations may vary depending on the timing horizon (Planning, Operating, or Scheduling) in which the ATC is being calculated.

Planning Horizon:

$$ATC_F = TTC - ETC_F - CBM - TRM + Postbacks_F + counterflows_F$$

$$ATC_{NF} = TTC - ETC_F - ETC_{NF} - CBM - TRM + Postbacks + counterflows$$

Operating Horizon:

$$ATC_F = TTC - ETC_F - CBM - TRM + Postbacks_F + counterflows_F$$

$$ATC_{NF} = TTC - ETC_F - ETC_{NF} - CBM - TRM + Postbacks + counterflows$$

Scheduling Horizon:

$$ATC_F = TTC - ETC_F - CBM - TRM + Postbacks_F$$

$$ATC_{NF} = TTC - ETC_F - ETC_{NF} - CBM - TRM + Postbacks$$

6.2 Counter Flows (MOD-001, R3.2, R3.2.1, R3.2.2 / MOD-029, R7, R8)

6.2.1 BHC has no counterflows that are allowed to create firm ATC in the opposite direction. BHC's rationale is that it does not want to offer firm transfer capability due to counterflow that may not be scheduled as this could lead to Curtailments of Firm Transmission Service in the Real-time horizon. (R3.2.1)

6.2.2 BHC has counterflows that are allowed to create non-firm ATC in the opposite direction. (R3.2.1)

6.2.3 BHC accounts for confirmed reservations, expected interchange, and internal counterflows in the ATC calculations in the following manner relative to the use of counterflows. The following formulas are used in calculating firm and non-firm ATC:

$$ATC_F = TTC - ETC_F - CBM - TRM + Postbacks_F \text{ (R3.2.2)}$$

$$ATC_{NF} = TTC - ETC_F - ETC_{NF} - CBM - TRM + Postbacks_{F,NF} + Counterflows_{F,NF} \text{ (R3.2.2)}$$

6.3 ATC Data Received from Others (MOD-001, R3.3)

BHC receives data from the following Transmission Operators for use in calculation of ATC:

- Western Area Power Administration – Rocky Mountain Region (WAPA-RMR)

- PacifiCorp (PAC)
- Public Service Company of Colorado (PSCo)
- Tri-State Generation and Transmission Association

The data typically includes, but is not limited to: loads, transmission topology, and resources.

6.4 TTC Data Provided to Others (MOD-001, R3.4)

The Transmission Provider provides data for use in calculating transfer capability to the entities listed in Section 6.3 above as requested. This data typically includes, but is not limited to: loads, system topology and resources.

6.5 TTC Allocation Process (MOD-001, R3.5)

BHC does not allocate transfer or Flowgate capability among multiple lines or sub-paths within a larger ATC Path or Flowgate.

BHC does not allocate transfer or Flowgate capabilities among multiple owners or users of an ATC Path or Flowgate.

BHC does not allocate transfer or Flowgate capabilities between Transmission Service Providers to address issues such as forward looking congestion management and seams coordination.

6.6 Consideration of Generation and Transmission Outages (MOD-001, R3.6)

Transmission outages and any impacting generator outages are entered into the outage management system and sent to the transmission scheduling system as soon as notifications are provided by the BHC Outage Coordinator. Generator outages do not impact TTC values for any BHC posted ATC paths. In the event of a transmission outage, the adjusted TTC values will be utilized in the calculation of ATC for all transmission services and time increments for the duration of the outage on each impacted path. Based on the outage information received, the magnitude and duration of impacts on the TTC on each bi-directional impacted path is determined prior to entry in the transmission scheduling system. Once entered, the transmission scheduling system will utilize the TTC values entered for the duration of the outage and at such time that the outage is no longer in effect, the transmission scheduling system will revert back to using the TTC values normally set for that particular path.

6.6.1 Daily & Monthly Calculation Impact (MOD-001, R3.6.1, R3.6.2)

If an outage will impact only a portion of a transmission service time period the TTC, and subsequently the ATC, will be reduced for the entire transmission service time period to prevent over-scheduling of the impacted path. An outage record may be changed to extend the outage, terminate the outage, or update information in the outage posting. As soon as an action is taken on the outage record, the record is immediately updated to reflect the new TTC value and associated path ATC values. Outage information entered into the outage management system is posted on the secure OATI OASIS website.

6.6.2 Outages External to BHC's System (MOD-001, R3.6.3)

Within the planning models, WECC models are utilized to formulate transfer capability values. Within the WECC models external lines and outages scenarios are evaluated and reflected for the impact on the system.

7. ATC ID Implementation Contact List (MOD-001 R4)

See Attachment A

8. TTC Study Assumptions (MOD-001 R6)

See Mod-029 §2.1

9. Revision History

Revision #	Revision Date	Description	Revised By	Reviewed By
0.0	11/03/2014	Initial Document Release	Larry Williamson	
0.1	05/02/2014	Keeping document up-to-date overview	Eric East	
1.0	11/03/2014	Combining of BHCE, CLFP, and BHCE into one document	Eric East	
1.1	08/03/2017	Updated Contact List	Eric Schiermeister	
1.2	01/09/2019	Annual review. No revisions.	Eric Schiermeister	Eric East
1.3	01/06/2020	Annual review. Updated contacts.	Eric Schiermeister	Eric East
1.4	12/30/2020	Annual review. Updated contacts.	Eric Schiermeister	Eric East
2.0	02/22/2021	New Format	Eric East	Eric East
2.1	02/15/2022	Annual review. Updated contacts.	Brandy Renville	Eric East
2.2	12/04/2023	Annual review. No revisions.	Brandy Renville	Eric East

(List every instance of the document being changed or reissued).

Attachment A

<i>Entity</i>	<i>Contact Information</i>	<i>Neighbor</i>	<i>Transmission Operator</i>	<i>Transmission Service Provider</i>	<i>Reliability Coordinator</i>	<i>Planning Coordinator</i>
Black Hills Power Black Hills Colorado Electric Cheyenne Light Fuel & Power	Lindsay Briggs, Supervisor, Transmission Planning 605.721.2240 Lindsay.Briggs@blackhillscorp.com		X	X		
Colorado Springs Utilities	Warren Rust, Operations Superintendent 719.668.4128 rust@csu.org Jeff Hanson, Principle Engineer 719.668.8125 jhanson@csu.org CSU Transmission Operations and Engineering C_TranOpsEng@csu.org	X	X	X		X
PacifiCorp	Veronica Whitesmith, Manager of Transmission Services veronica.whitesmith@pacificorp.com	X	X	X		X
Southwest Power Pool	OpsAFCEng@spp.org				X	
Platte River Power Authority	Matthew Thompson, System Operation Compliance Specialist 970.219.7617 thompsonm@prpa.org Derek Book, System Operations Engineer 970.229.5391 bookd@prpa.org	X	X	X		X
Public Service Company of Colorado	Bob Staton, Control Center Manager 303.273.4797 Robert.staton@xcelenergy.com Brett Gruesner, Network Reliability Lead 303.273.4782 Brett.J.Gruenesner@xcelenergy.com PSCo Transmission Compliance PSCoTransCompliance@xcelenergy.com	X	X	X		X
Tri-State Generation & Transmission Association, Inc.	Shannon Bernard, OASIS/OATT Administrator 303.254.3676 sbernard@tristategt.org Sergio Banuelos	X	X	X		

	Reliability Compliance Specialist 303.254.3231 serban@tristategt.org					
Western Area Power Administration	Brent Sessions, VP Risk and Reliability Compliance 720.962.7324 sessions@wapa.gov Kristen McClure, Transmission Services Program Manager 602.605.2840 mcclure@wapa.gov John Steward, Transmission Business Unit Manager 602.605.2774 steward@wapa.gov Reliability Compliance reliabilitycompliance@wapa.gov	X	X	X		X

Black Hills Energy Transmission Reliability Margin Implementation Document (TRMID)

 BLACK HILLS CORPORATION COMPANY POLICY		
Affected Business Unit(s): Black Hills Power, Inc. (BHBE) Cheyenne Light Fuel Power Company (CLPT) Black Hills Colorado Electric, LLC (BHCT)	Originating Department(s): FERC Tariff & Contracts	
	Effective Date: 2/22/2021	
Procedure No.: OASIS 3.3	Revision Date: 2/22/2021	Rev 1.0
MOD-008-1 TRM ID		

10. Background

MOD-008-1 is utilized to promote the consistent and reliable calculation, verification, preservation, and use of Transmission Reliability Margin (TRM) to support analysis and system operations.

11. Purpose

This Transmission Reliability Margin Implementation Document provides for the documentation of non-use of Transmission Reliability Margin.

12. Definitions

12.7 Terms used in this document align with the definitions identified in the NERC Glossary of Terms and the NERC MOD Standards.

12.8 Specific terms to this Transmission Provider are as listed:

12.8.3 Available Transfer Capability (ATC) – A measure of the transfer capability remaining in the physical transmission network for further commercial activity over and above already committed uses.

12.8.4 Capacity Benefit Margin (CBM) – The amount of firm transmission transfer capability preserved by the transmission provider for Load-Serving Entities (LSE), whose loads are located on that Transmission Service Provider’s system, to enable access by the LSEs to generations from interconnected systems to meet generation reliability requirements. The transmission transfer capability preserved as CBM is intended to be used by the LSE only in times of emergency generation deficiencies.

12.8.5 Transmission Reliability Margin (TRM) – The amount of transmission transfer capability necessary to provide reasonable assurance that the interconnected transmission network will be secure. TRM accounts for the inherent uncertainty in system conditions and the need for operating flexibility to ensure reliable system operation as system conditions change.

13. Requirements

13.1 The following requirements from NERC Standard MOD-008-1, Available Transmission System Capability are applicable to this document:

13.1.1 Identification of (on each of its respective ATC paths or Flowgates) each of the following components of uncertainty if used in establishing TRM, and a description of how that component is used to establish a TRM value:

- Aggregate Load Forecast
- Load distribution uncertainty
- Forecast uncertainty in Transmission system topology (including, but not limited to, forced or unplanned outages and maintenance outages).
- Allowances for parallel path (loop flow) impacts
- Variations in generation dispatch (including, but not limited to, forced or unplanned outages, maintenance outages and location of future generation).
- Short-term System Operator response (Operating Reserve actions).
- Reserve sharing requirements.
- Inertial response and frequency bias.

13.1.2 The description of the method used to allocate TRM across ATC Paths or Flowgates. **(R1.2)**

13.1.3 The identification of the TRM calculation used for the following time periods: **(R1.3)**

- Same day and real-time. **(R1.3.1)**
- Day-ahead and pre-schedule. **(R1.3.2)**
- Beyond day-ahead and pre-schedule, up to thirteen months ahead. **(R1.3.3)**

13.1.4 Each Transmission Operator shall only use the components of uncertainty from R1.1 to establish TRM and shall not include any of the components of Capacity Benefit Margin (CBM). Transmission capacity set aside for reserve sharing agreements can be included in TRM. **(R2)**

14. Implementation

14.2 Of the components of uncertainty noted in Section 3.1.1 above, the Transmission Provider uses only reserve sharing requirements in establishing TRM. **(R1.1)**

14.3 The Transmission Provider does not allocate TRM on any of the ATC Paths within the NorthWest Power Pool Reserve Group (NWPP). Black Hills Energy's Balancing Authorities WACM and PSCO do carry TRM but do not require the sub-entity members to. No transmission reservation is necessary to deliver emergency energy.

14.4 The TRM calculation is the same across all time periods noted in Section 4.1.3 above per the allocation methodology identified in Section 4.2. **(R1.3.1, R1.3.2, R1.3.3, R4)**

Planning Horizon:

$$ATC_F = TTC - ETC_F - CBM - TRM + Postbacks_F + counterflows_F$$

$$ATC_{NF} = TTC - ETC_F - ETC_{NF} - CBM - TRM + Postbacks + counterflows$$

Operating Horizon:

$$ATC_F = TTC - ETC_F - CBM - TRM + Postbacks_F + counterflows_F$$

$$ATC_{NF} = TTC - ETC_F - ETC_{NF} - CBM - TRM + Postbacks + counterflows$$

Scheduling Horizon:

$$ATC_F = TTC - ETC_F - CBM - TRM + Postbacks_F$$

$$ATC_{NF} = TTC - ETC_F - ETC_{NF} - CBM - TRM + Postbacks$$

14.5 Black Hills Corporation does not use CBM in its calculation of ATC. (R2)

14.6 Black Hills Corporation will review its allocation methodology of TRM at least annually (every 12 months), or as conditions warrant a review. (R4)

14.7 The Transmission Provider will disseminate TRM allocation information in accordance with NERC MOD Standard 008-01.

15. Revision & Version (REV-VER) Designations

15.8 A change to the Revision indicates a significant change to the document.

15.9 A change to the Version indicates an insignificant change to the document, not affecting content.

16. Revision History

Revision #	Revision Date	Description	Revised By	Reviewed By
0.0	04/01/2011	Initial Document Release	Larry Williamson	
0.1	11/12/2013	Document Revision	Eric East	Eric East
0.2	12/31/2013	Change to TRM methodology based on RMRG Bylaws	Eric East	Kenna Hagan
0.3	10/29/2014	Review	Eric East	Eric East
1.0	01/05/2015	Language Changes	Eric Schiermeister	Eric East
2.0	02/22/2021	New Format	Eric East	Eric East
2.0	07/14/2021	Review	Eric East	Eric East
(List every instance of the document being changed or reissued).				

Black Hills Energy Capacity Benefit Margin Implementation Document (CBMID)

 BLACK HILLS CORPORATION COMPANY POLICY	
Affected Business Unit(s): Black Hills Power, Inc. (BHBE) Cheyenne Light Fuel Power Company (CLPT) Black Hills Colorado Electric, LLC (BHCT)	Originating Department(s): FERC Tariff & Contracts Effective Date: 2/22/2021
Procedure No.: OASIS 003.2	Revision Date: 12/21/2023
MOD-004-1 CBMID	

17. Purpose

MOD-004-1 is utilized to promote the consistent and reliable calculation, verification, preservation, and use of Capacity Benefit Margin (CBM) to support analysis and system operations.

18. Definitions

18.10 Terms used in this document align with the definitions identified in the NERC Glossary of Terms and the NERC MOD Standards.

18.11 Specific terms specific to this Transmission Provider are as listed:

18.11.5 Available Transfer Capability (ATC) – A measure of the transfer capability remaining in the physical transmission network for further commercial activity over and above already committed uses.

18.11.6 Capacity Benefit Margin (CBM) – The amount of firm transmission transfer capability preserved by the transmission provider for Load-Serving Entities (LSE), whose loads are located on that Transmission Service Provider’s system, to enable access by the LSEs to generations from interconnected systems to meet generation reliability requirements. The transmission transfer capability preserved as CBM is intended to be used by the LSE only in times of emergency generation deficiencies.

19. Requirements

19.12 NERC Standard MOD-004-1

19.12.1 R1.1. The process through which a Load-Serving Entity within a Balancing Authority Area associated with the Transmission Service Provider, or the Resource Planner associated with that Balancing Authority Area, may ensure that its need for Transmission capacity to be set aside as CBM will be reviewed and accommodated by the Transmission Service Provider to the extent Transmission capacity is available.

19.12.2 R1.2. The procedure and assumptions for establishing CBM for each Available Transfer Capability (ATC) Path or Flowgate.

19.12.3 R1.3. The procedure for a Load-Serving Entity or Balancing Authority to use Transmission capacity set aside as CBM, including the manner in which the Transmission Service Provider will manage situations where the requested use of CBM exceeds the amount of CBM available.

19.12.4 R2. The Transmission Service Provider that maintains CBM shall make available its current CBMID to the Transmission Operators, Transmission Service Providers, Reliability Coordinators, Transmission Planners, Resource Planners, and Planning Coordinators that are within or adjacent to the Transmission Service Provider's area, and to the Load Serving Entities and Balancing Authorities within the Transmission Service Provider's area, and notify those entities of any changes to the CBMID prior to the effective date of the change.

19.12.5 R3. Each Load-Serving Entity determining the need for Transmission capacity to be set aside as CBM for imports into a Balancing Authority Area shall determine that need by:

- **R3.1.** Using one or more of the following to determine the GCIR:
 - Loss of Load Expectation
 - Loss of Load Probability
 - Deterministic Risk Analysis Studies
 - Reserve margin or resource adequacy requirements established by other entities, such as municipalities, state commissions, regional transmission organizations, independent system operators, Regional Reliability Organizations, or regional entities
- **R3.2.** Identifying expected import path(s) or source region(s).

19.12.6 R4 Each Resource Planner determining the need for Transmission capacity to be set aside as CBM for imports into a Balancing Authority Area shall determine that need by:

- **R4.1** Using one or more of the following the determine the GCIR:
 - Loss of Load Expectation
 - Loss of Load Probability
 - Deterministic Risk Analysis Studies
 - Reserve margin or resource adequacy requirements established by other entities, such as municipalities, state commissions, regional transmission organizations, independent system operators, Regional Reliability Organizations, or regional entities
- **R4.2** Identifying expected import path(s) or source region(s).

19.12.7 R5 At least every 13 months, the Transmission Service Provider that maintains CBM shall establish a CBM value for each ATC Path or Flowgate to be used for ATC or Available Flowgate Capability (AFC) calculations during the 13 full calendar months (months 2-14) following the current month (the month in which the Transmission Service Provider is establishing the CBM values). This value shall:

- **R5.1** Reflect consideration of each of the following if available:
 - Any studies (as described in R3.1) performed by Load-Serving Entities for loads within the Transmission Service Provider's area
 - Any studies (as described in R4.1) performed by Resource Planners for loads within the Transmission Service Provider's area

- Any reserve margin or resource adequacy requirements for loads within the Transmission Service Provider's area established by other entities, such as municipalities, state commissions, regional transmission organizations, independent system operators, Regional Reliability Organizations, or regional entities
- **R5.2** Be allocated as follow:
 - **R5.2.1** Any studies (as described in R3.1) performed by Load-Serving Entities for loads within the Transmission Service Provider's area
 - **R5.2.2** Any studies (as described in R4.1) performed by Resource Planners for loads within the Transmission Service Provider's area
 - **R5.2.3** Any reserve margin or resource adequacy requirements for loads within the Transmission Service Provider's area established by other entities, such as municipalities, state commissions, regional transmission organizations, independent system operators, Regional Reliability Organizations, or regional entities

19.12.8 R6 At least every 13 months, the Transmission Planner shall establish a CBM value for each ATC Path or Flowgate to be used in planning during each of the full calendar years two through ten following the current year (the year in which the Transmission Planner is establishing the CBM values). This value shall:

- **R6.1** Reflect consideration of each of the following if available:
 - Any studies (as described in R3.1) performed by Load-Serving Entities for loads within the Transmission Planner's area
 - Any studies (as described in R4.1) performed by Resource Planners for loads within the Transmission Planner's area
 - Any reserve margin or resource adequacy requirements for loads within the Transmission Planner's area established by other entities, such as municipalities, state commissions, regional transmission organizations, independent system operators, Regional Reliability Organizations, or regional entities
- **R6.2** Be allocated as follows:
 - For ATC Paths, based on the expected import paths or source regions provided by Load-Serving Entities or Resource Planners
 - For Flowgates, based on the expected import paths or source regions provided by Load-Serving Entities or Resource Planners and the distribution factors associated with those paths or regions, as determined by the Transmission Planner.

19.12.9 R7. Less than 31 calendar days after the establishment of CBM, the Transmission Service Provider that maintains CBM shall notify all the Load-Serving Entities and Resource Planners that determined they had a need for CBM on the Transmission Service Provider's system of the amount of CBM set aside.

19.12.10 R8. Less than 31 calendar days after the establishment of CBM, the Transmission Planner shall notify all the Load-Serving Entities and Resource Planners that determined they had a need for CBM on the system being planned by the Transmission Planner of the amount of CBM set aside.

19.12.11 R9. The Transmission Service Provider that maintains CBM and the Transmission Planner shall each provide (subject to confidentiality and security requirements) copies of the applicable supporting data, including any models, used for determining CBM or allocating CBM over each ATC Path or Flowgate to the following:

- **R9.1** Each of its associated Transmission Operators within 30 calendar days of their making a request for the data.
- **R9.2** To any Transmission Service Provider, Reliability Coordinator, Transmission Planner, Resource Planner, or Planning Coordinator within 30 calendar days of their making a request for the data

19.12.12 R10. The Load-Serving Entity or Balancing Authority shall request to import energy over firm Transfer Capability set aside as CBM only when experiencing a declared NERC Energy Emergency Alert (EEA) 2 or higher.

19.12.13 R11. When reviewing an Arranged Interchange using CBM, all Balancing Authorities and Transmission Service Providers shall waive, within the bounds of reliable operation, any Real-time timing and ramping requirements.

19.12.14 R12. The Transmission Service Provider that maintains CBM shall approve, within the bounds of reliable operation, any Arranged Interchange using CBM that is submitted by an “energy deficient entity” under an EEA 2 if:

- The CBM is available
- The EEA 2 is declared within the Balancing Authority Area of the “energy deficient entity,” and
- The Load of the “energy deficient entity” is located within the Transmission Service Provider’s area.

19.13 Code of Federal Regulations

19.13.1 CFR 37.6 (b)(iii)(A) - The Transmission Provider must reevaluate its CBM needs at least every year.

19.13.2 CFR 37.6 (b)(iii)(B) - The Transmission Provider must post its practices for reevaluating its CBM needs.

20. Implementation

20.14 NERC Standard MOD-004-1

20.14.1 R1.1. Process for Reviewing and Accommodating CBM

An LSE shall use the following steps to request the set aside of CBM capacity:

1. Determine the amount of CBM to be requested of the applicable Transmission Provider using the methodology described in MOD-004, R3.

2. Document the methodology and amount being requested in a formal letter, and on which path.
3. Submit that letter to transmissionservice@blackhillscorp.com or via standard mail to:

Black Hills Energy
ATTN: Reliability Center
7001 Mt Rushmore Rod
Rapid City, SD 57702
4. The Transmission Provider will determine availability for CBM and respond to submitting party within thirty (30) calendar days.

A Resource Planner shall use the following steps to request the set aside of CBM capacity:

1. Determine the amount of CBM to be requested of the applicable Transmission Provider using the methodology described in MOD-004, R3.
2. Document the methodology and amount being requested in a formal letter, and on which path.
3. Submit that letter to transmissionservice@blackhillscorp.com or via standard mail to:

Black Hills Energy
ATTN: Reliability Center
7001 Mt Rushmore Rod
Rapid City, SD 57702
4. The Transmission Provider will determine availability for CBM and respond to the submitting party within thirty (30) calendar days.

20.14.2 R1.2. Procedure and Assumptions for Establishing CBM

Upon receipt of a request form an LSE or Resource Planner, the Transmission Provider shall process requests for CBM comparably, and will apply the following steps:

1. Determine if firm ATC is available on the path being requested for the two-year period following the beginning date of the request.
2. Recommend alternative paths for CBM if requested path is unavailable.
3. Ensure that the capacity being requested has been developed using the methodology in MOD-004, R3 or R4.
4. Review availability of CBM on a two-year basis, beginning concurrently with the requested CBM service date.

20.14.3 R1.3 Procedure for LSE or BA to use CBM

The Transmission Provider documents the use of CBM as outlined in this CBMID.

20.14.4 R2 CBMID Availability

The Transmission Provider will maintain a current copy of its CBMID on its OASIS site. Additionally, the Transmission Provider will supply an electronic copy to the applicable entities listed in requirement R2 on or before the effective date of any change of the CBMID. A notification will be posted on OASIS.

20.14.5 R5 Maintenance of an Established CBM Value

The Transmission Provider does not maintain a CBM value, and therefore does not establish a new CBM value at least once every 13 months, but the Transmission Provider does review annually the need for CBM.

20.14.6 R6 Establishment of a new CBM value for the planning period

The Transmission Provider has received no request for CBM to date, and will not establish a CBM value until it has received such a request from an LSE or Resource Planner under the process outlined above. Once such request has been made, this CBMID will be revised and a new CBM value will be established for the required period.

21. Revision History

Revision #	Revision Date	Description	Revised By
0.0	04/01/2011	Initial Document Release	Larry Williamson
1.0	09/12/2013	Revision	Eric East
1.1	10/29/2014	Review	Eric East
1.2	01/05/2015	Language Changes	Eric Schiermeister
2.0	02/22/2021	New Format	Eric East
2.0	07/14/2021	Review	Eric East
2.0	06/29/2022	Review	Jacki Welbig-Stenson
3.0	12/21/2023	Annual Evaluation of CBM Need	Eric East

Black Hills Energy Economic Planning Study Request Form

Transmission Provider Economic Planning Study Request Form

Stakeholders may request Transmission Provider to perform a high-priority Economic Planning Study. All such requests must satisfy the criteria.

- 1 All requests for high priority Economic Planning Studies must be submitted to Transmission Provider in writing signed by the stakeholder making the request.
- 2 The written request must set forth, in detail and consistent with FERC policy, why a High-Priority Economic Study is justified. The justification should address all relevant facts that indicate that the study is "... for the purposes of planning for the alleviation of congestion through integration of new supply and demand resource into the regional transmission grid or expand the regional transmission grid in a manner that can benefit large numbers of customers, such as by evaluating transmission upgrades necessary to connect major new areas of generation resource (such as areas that support substantial wind generation). Specific requests for service would continue to be studied pursuant to existing pro forma OATT processes.”¹⁰
- 3 This letter also must include, at a minimum the following information.
 - 3.1 Contact Information including the name of sponsor, business address, mailing address, email address and phone number.
 - 3.2 A statement that the request is not a request for single transmission service request or generation interconnection request.
 - 3.3 A defined point of receipt and point of delivery are defined.
 - 3.4 A defined monthly or hourly MW amount.
 - 3.5 A defined monthly energy in KWh.
 - 3.6 If the requestor’s own generation is affected by the request, the following information must be provided: economic dispatch costs, hourly generation patterns, relevant maintenance information; expected generation forced outage rate; and all other factors affecting generation output.
 - 3.7 If the requestor’s own load is affected by the request, then the expected change in hourly load profile must be provided.
 - 3.8 If the request involves or affects third party generation or load, all public information for this third party generation or load (as described in 3.2-3.7) in possession of the requestor must be provided.
- 4 A statement that the requestor will provide, to the greatest extent practical, additional information and agrees to cooperate with Transmission Provider as necessary to complete the economic study.
- 5 Sponsors of the Economic Study Request are invited to participate in Transmission Provider’s open TCPC meeting where prioritization will be discussed.

¹⁰ Paragraph 549, FERC Order 890, OATT Reform.
BHCT_Economic_Planning_Study_Request_Form – Revised: 3-3-11

Black Hills Energy Facility Rating Methodology

DOCUMENT TITLE: BHC Facility Rating Methodology	EFFECTIVE DATE: 31-Dec-2012	DOCUMENT NO. TP-P-002
DOCUMENT OWNER: Lindsay Briggs, Manager of Transmission Planning	REVISED DATE: 13-Mar-2023	REV. VER: 3.0
		Page 155 of 261
		CONFIDENTIALITY CATEGORY: Public

Table of Contents

1	Purpose.....	158
1.1	Statement on Facility Rating limits (FAC-008-5 R2.3 and R3.3)	158
1.2	Method to Determine Most Limiting Facility.....	158
2	Definitions.....	158
2.1	Terms defined in the “Glossary of Terms Used in NERC Reliability Standards”.....	158
3	Scope.....	159
4	Generation Facility Rating Methodology.....	159
4.1	General.....	159
4.2	Generators.....	159
4.3	GSU Transformers.....	159
4.4	Generation Facility Electric Equipment.....	159
5	Transmission Facility Rating Methodology.....	160
5.1	Transformers.....	160
5.2	Bare Overhead Flexible Conductors.....	160
5.3	Rigid Bus Conductors.....	161
5.4	Circuit Breakers	162
5.5	Instrument Transformers.....	162
5.6	Switches.....	163
5.7	Protective Equipment.....	163
5.8	Line Traps	163
5.9	Series Compensation Devices.....	163
5.10	Shunt Capacitors	163
5.11	Shunt Reactors	163
6	Roles and Responsibilities	163
6.1	Transmission Planning.....	164

DOCUMENT TITLE: BHC Facility Rating Methodology	EFFECTIVE DATE: 31-Dec-2012	DOCUMENT NO. TP-P-002
DOCUMENT OWNER: Lindsay Briggs, Manager of Transmission Planning	REVISED DATE: 13-Mar-2023	REV. VER: 3.0
		Page 156 of 261
		CONFIDENTIALITY CATEGORY: Public

6.2	Transmission & Distribution Engineering	164
6.3	Substation & Protection Engineering.....	164
6.4	Electrical Maintenance.....	164
6.5	Reliability Center / Operational Support	165
6.6	Power Delivery	165
7	Facility Rating Process	165
8	Points of Contact	165
9	Revision History	165
	Appendix A.....	168
	Appendix B.....	172

Subject Matter Expert (SME) Review			
Department	Name	Title	Signature & Date
Transmission Planning	Lindsay Briggs	Manager	
T&D Engineering	Scott Fredrich	Manager	
Substation Engineering	Ryan Berlin	Manager	
Protection Engineering	Brian Kittelson	Manager	
Maintenance Services	Ron Wilgers	Sr. Manager	
Reliability Center	Denton McGregor	Sr. Manager	
Operational Services	Daniel Alsup	Manager	
Power Delivery	Carly Miller	Manager	

1 Purpose

This document contains the philosophies and methodology used for determining and communicating Facility Ratings for solely and jointly owned transmission and generation Facilities of Black Hills Corporation's (BHC) subsidiaries: Black Hills/Colorado Electric (BHCE), Black Hills Power (BHP), Black Hills Wyoming (BHW), Black Hills Colorado IPP (BHCI) and Cheyenne Light, Fuel and Power (CLFP). The document also defines the basis for the calculation of Normal and Emergency Ratings of BHC Facilities at 100 kV and above to satisfy the requirements of NERC Reliability Standard FAC-008-5. For the remainder of this document the term BHC shall be read to include BHCE, BHP, BHW, BHCI and CLFP except as otherwise noted.

1.1 Statement on Facility Rating limits (FAC-008-5 R2.3 and R3.3)

The Facility Rating for transmission and generation facilities shall respect the most limiting applicable Equipment Rating of the individual equipment that comprises that Facility. For jointly owned transmission and generation facilities, BHC will coordinate its equipment ratings with the other facility owner's equipment ratings to determine the most limiting applicable Equipment Rating of the individual equipment that comprises that Facility.

1.2 Method to Determine Most Limiting Facility

BHC has developed a rating methodology for each major component of equipment that comprises a Facility. All series equipment that together make up a line section, transmission substation transformer circuit, or shunt reactive device are reviewed to determine which item of equipment has the most limiting rating, which will be used as the most limiting component in determining the normal and emergency ratings for the transmission facility.

All series equipment that together make up the generating facility from the generator to, and possibly including, the generator step-up transformer are reviewed to determine which item of equipment has the most limiting rating, will be used as the most limiting component in determining the normal and emergency ratings for the generating facility. Generator Owner equipment connected between the point of interconnection up to, and possibly including, the generator step-up transformer will have Facility Ratings determined per the Transmission Facility Rating Methodology in Section 5 below.

2 Definitions

2.1 Terms defined in the "Glossary of Terms Used in NERC Reliability Standards"

2.1.1 This document defines the following terms typically per the revision of the "[Glossary of Terms Used in NERC Reliability Standards](#)" dated December 2, 2022:

2.1.2 **Element:** Any electrical device with terminals that may be connected to other electrical devices such as a generator, transformer, circuit breaker, bus section, or transmission line. An element may be comprised of one or more components.

2.1.3 **Equipment Rating:** The maximum and minimum voltage, current, frequency, real and reactive power flows on individual equipment under steady state, short-circuit and transient conditions, as permitted or assigned by the equipment owner.

2.1.4 **Facility:** A set of electrical equipment that operates as a single BES Element (e.g., a line, a generator, a shunt compensator, transformer, etc.). Appendix B contains more details on what equipment is considered for each facility.

2.1.5 **Facility Rating:** The maximum or minimum voltage, current, frequency, or real or reactive power flow through a facility that does not violate the applicable Equipment Rating of any equipment comprising the Facility.

2.1.6 **Emergency Rating:** The rating as defined by the equipment owner that specifies the level of electrical loading or output, usually expressed in Amps, MVA or other appropriate units, that a system, facility, or element can support, produce, or withstand for a finite period. The

rating assumes acceptable loss of equipment life or other physical or safety limitations for the equipment involved.

2.1.7 Normal Rating: The rating as defined by the equipment owner that specifies the level of electrical loading, usually expressed in Amps, MVA or other appropriate units that a system, facility, or element can support or withstand through the daily demand cycles without loss of equipment life.

2.1.8 Reasonability Limit: The value representing the maximum measurement capability of an element, determined by the maximum reading of terminal equipment instrumentation and widest range of SCADA/EMS measurement capabilities.

2.1.9 Summer: The time period associated with seasonal ratings extending from April 1 thru November 30.

2.1.10 Winter: The time period associated with seasonal ratings extending from December 1 thru March 31.

3 Scope

3.1.1 This procedure is to ensure the Facility Ratings, used in the reliable planning and operations of the BHC Facilities are determined based on an established methodology.

3.1.2 This document describes BHC's ratings methodology and compliance with NERC reliability standard FAC-008-5. The appendices to this document assign ratings responsibilities, outlines the Facility Ratings process and records associated with establishing, updating, issuing, and disseminating accurate and appropriate ampacity ratings for BHC Facilities

3.1.3 This document is applicable to all personnel engaged in planning, engineering, maintenance, construction and operation of BHCs Facilities.

4 Generation Facility Rating Methodology

4.1 General

All BHC solely or jointly owned generator Facilities are described as consisting of the generator and all applicable equipment from the generator to the point of interconnection with the Transmission Owner. The generation facilities generally consist of the generator, the generator step-up transformer (GSU), and the associated equipment between the generator and the GSU.

4.2 Generators

BHC rates generators based on the manufacturer's nameplate. The generators are not operated above the nameplate rating. Therefore, Emergency Ratings are considered the same as the Normal Ratings. Operating limitations may be included if applicable.

4.3 GSU Transformers

The GSU transformers will be rated according to the methods described in Section 5.1.

4.4 Generation Facility Electric Equipment

The electric equipment connecting the generator and the GSU transformer will be rated per documented manufacturer's design criteria, equipment nameplate ratings, engineering analyses, and industry standards. All assumptions utilized in determining generator Facility Ratings shall be clearly identified within the supporting documentation. Further details on the rating methodology for generation facility equipment are included in Section 5.

Each generation Facility Rating must take into account any known limitations based on operating conditions, etc. according to good utility practice.

5 Transmission Facility Rating Methodology

The transmission facilities owned by BHC's transmission-owner ("TO") subsidiaries as well as those owned by the generator-owner ("GO") subsidiaries will be similarly rated according to this methodology as described in Sections 5.1 through 5.11

5.1 Transformers

All transformers with low-side windings connected at 69 kV nominal or above have been rated in accordance with the manufacturer's specifications as well as IEEE Standard C57.91-(*latest version*).

5.1.1 The Normal Rating for power transformers is 100% of the manufacturer's highest continuous nameplate (AN, AF, ON, OF, or OD) rating. When available, the normal rating will use the 65 °C temp rise nameplate rating. The 55 °C temp rise rating will only be used if a 65 °C temp rise rating is not listed.

5.1.2 The Emergency Rating for power transformers is based on the manufacturers stated nameplate Emergency Rating, however if the manufacturer does not specify an Emergency Rating then BHC will assume 125% of the Normal Rating for a maximum of 30 minutes.

BHC may allow for a Normal and/or Emergency Rating beyond the stated value which will be determined on a per Facility basis and through an engineering analysis of that Facility consistent with the IEEE/ANSI standards listed above or other appropriately established criteria. Power transformers may also be subject to ambient conditions that may result in the adjustment of the manufacturers rating due to real-time conditions such as temperature. Operating limitations may also be placed on the power transformers such as de-rating due to impaired equipment which follows good utility practice.

5.2 Bare Overhead Flexible Conductors

The rating of a transmission conductor is the amount of current, measured in amperes (amps), which can be safely carried over the line. BHC's transmission line ratings are based on IEEE Standard 738-2012 for calculating the current-temperature relationship of bare overhead conductors and are calculated using commercially available computer software unless otherwise specified. BHC calculates Normal and 2-Hour Emergency ratings on transmission conductors based on the maximum conductor temperatures for the conductor types included in **Table 5-1**. Normal and Emergency conductor ratings for conductor types not included in **Table 5-1** are determined on a per Facility basis through an Engineering analysis. Input variables required for the Normal and Emergency ratings calculations include physical conductor properties obtained from the appropriate conductor reference. BHC may allow for a Normal and/or Emergency Rating beyond the stated value which will be determined on a per Facility basis and through an Engineering analysis of that Facility consistent with the IEEE/ANSI Standards listed above or other appropriately established criteria.

Variables needed to establish conductor ratings which **ARE NOT** location dependent are included in **Table 5-2**. Other conductor variables needed to establish conductor ratings which **ARE** location dependent are included in **Table 5-3**. All other input variables not identified in **Table 5-2** and **Table 5-3** are based upon the design of the specific transmission facility.

Table 5-1: Maximum Conductor Temperatures

Conductor Type	Normal Ratings Conductor Temperature (°C)	2-Hour Emergency Ratings Conductor Temperature (°C)
ACCC	180	200
ACSR	95	100
AAC	95	100

Table 5-2: Environment Variable Assumptions

Parameter	Value
Ambient air temperature (Summer) (°C/°F)	40 / 104
Ambient air temperature (Winter) (°C/°F)	10 / 50
Transmission Line Wind Speed (mps/fps)	1.22 / 4.0
Substation Conductor Wind Speed (mps/fps)	0.6 / 2.0
Wind Direction	Perpendicular to conductor axis (90°)
Line Orientation	East-West (90° or 270°)
Summer Reference Date	June 10
Winter Reference Date	December 10
Time of Day	12:00 pm
Atmosphere	Clear
Absorptivity	0.5
Emissivity	0.5

Table 5-3: Location Variable Assumptions

Parameter	BHCE	BHP	CLFP
Latitude (°N)	38.00	44.00	41.00
Elevation (ft)	4700	3100	6100

5.2.1 Flexible Substation Conductors

Substation conductors, such as strain bus and equipment jumpers within the substation will utilize the conductor assumptions identified in **Table 5-2** and **Table 5-3**. Additionally, substation conductors will utilize the substation conductor wind speed found in **Table 5-2**. Substation conductor ratings are calculated using commercially available computer software unless otherwise specified.

5.2.2 Transmission Line Conductors

Transmission line conductors will utilize the environment and location assumptions identified in **Table 5-2** and **Table 5-3**, and the maximum conductor temperature in **Table 5-1** or as determined by specific Engineering Analysis based upon the transmission line design and/or minimum safety clearances. Unless otherwise specified in the equipment rating documentation, transmission line jumpers between a transmission line and substation equipment will utilize the transmission line assumptions identified in **Table 5-1**, **Table 5-2**, and **Table 5-3**. Commercially available computer software is used in the calculation of line jumper ratings unless otherwise specified.

5.3 Rigid Bus Conductors

The rigid bus conductor ratings are determined per IEEE Standard 605-2008. Normal and 2-Hour Emergency Ratings for rigid bus conductors used in outdoor substations are based on the ampacity tables within IEEE Standard 605-2008 Annex B for the appropriate bus type with the assumptions noted in **Table 5-4**. Operating limitations may also be placed on the rigid bus conductors such as a de-rate due to impaired equipment.

Table 5-4: Rigid Bus Variable Assumptions

Parameter	Normal Ratings Value	2-Hour Emergency Ratings Value
Ambient Temperature	40°C	40°C
Latitude	40°N	40°N
Bus Direction	East-West	East-West
Wind Speed (fps/mps)	2.0 / 0.6	2.0 / 0.6
Wind Direction	Perpendicular to conductor axis	Perpendicular to conductor axis
Solar Absorptivity	0.5	0.5
Emissivity (with sun)	0.5	0.5
Temp Rise (above 40°C ambient)	40°C	50°C

5.4 Circuit Breakers

High-voltage circuit breakers are specified by operating voltage, continuous current, interrupting current and operating time in accordance with IEEE Standards C37 series. These ratings are indicated on the individual circuit breaker nameplate. BHC rates transmission circuit breakers according to the manufacturer’s specifications.

The normal rating for BHC transmission circuit breakers are rated as shown on the manufacturer’s nameplate. Nameplate interrupting ratings are adjusted for reclosing of oil circuit breakers per IEEE Standard C37.04. BHC does not have ratings above normal for transmission circuit breakers therefore no emergency ratings are provided as they would be equal to the normal ratings.

5.5 Instrument Transformers

Free standing current transformers, metering units or voltage transformers, are specified in accordance with IEEE Standard C57.13.

BHC rates transmission instrument transformers according to the manufacturer’s specifications. The Normal Ratings for BHC transmission instrument transformers are rated as shown on the manufacturer’s nameplate. BHC accounts for the tapped ratio and the thermal rating factor when rating current transformers. BHC allows for ratings above normal for transmission instrument transformers as allowed per the manufacturer.

5.5.1 Reasonability Limits of Instrument Transformers

To account for real-time adjusted ambient air temperatures and ensure the reliability of BHC’s transmission system equipment, reasonability limits are set by the maximum reading that can be measured by an instrument transformer and read into the SCADA/EMS. Transmission lines may be capable of delivering a higher rating of current than the reasonability limit, which may lead to the use of software modeling and simulations to ensure system operating limits are not exceeded. The maximum reading of the instrument transformers is included and noted as a limiting element within BHC’s rating analysis to

ensure that BHC is using appropriate real-time values for the full range of element capacity; however, instrument transformer limitations are not included in the calculation of Normal and Emergency ratings.

5.6 Switches

Transmission switches are specified in accordance with IEEE Standard C37.37.

BHC rates transmission switches according to the manufacturer's specifications. The Normal Ratings for BHC switches are rated as shown on the manufacturer's nameplate. Emergency ratings shall be equal to normal ratings.

5.7 Protective Equipment

PRC-023-4 states that each TO and GO shall use the standard criteria to prevent its phase protective relay settings from limiting transmission system loadability while maintaining reliable protection of the BES for all fault conditions. The facility rating may be limited by protective relay settings for low risk scenarios where facility overloads are unlikely. For these situations, the PRC-023-4 criteria will be used to determine a reasonable facility rating based on the existing protection settings.

5.8 Line Traps

Line traps are specified in accordance with ANSI Standard C93.3.

BHC will utilize the manufacturer's continuous nameplate rating for both Normal and Emergency Ratings for all seasons except for air-core inductor type line traps. Air-core inductor type line traps will be allowed to have a 2-hour Emergency Rating equal to 110% of the Normal Rating within the limits allowed by ANSI Standard C93.3. This Emergency Rating will not be utilized in planning assessments, but will be available in the operating time frame.

5.9 Series Compensation Devices

BHC rates transmission series compensation devices according to the manufacturer's specifications. The Normal Rating for transmission series compensation devices are rated as shown on the manufacturer's nameplate. Emergency ratings shall be equal to normal ratings.

5.10 Shunt Capacitors

Transmission shunt capacitors are specified in accordance with IEEE Standard C57.21.

BHC rates transmission shunt capacitors according to the manufacturer's specifications. The Normal Ratings for BHC shunt capacitors are rated as shown on the manufacturer's nameplate. Emergency ratings shall be equal to normal ratings.

5.11 Shunt Reactors

Transmission shunt reactors are specified in accordance with IEEE Standard 18, IEEE Standard 1036 and IEEE Standard C37.99.

BHC rates transmission shunt reactors according to the manufacturer's specifications. The Normal Ratings for BHC shunt reactors are rated as shown on the manufacturer's nameplate. Emergency ratings shall be equal to normal ratings.

6 Roles and Responsibilities

The specific roles and responsibilities of the individual groups within BHC as they pertain to BHC Facility Ratings include but are not limited to the items described below. Each BHC group listed below is responsible for their portion of the data provided and work performed as listed.

6.1 Transmission Planning

- 6.1.1 Maintain system planning models and associated change files (PSS/E format).
- 6.1.2 Communicate changes in system planning models to Operations Support.
- 6.1.3 Maintain the BHC Facility Ratings Methodology (TP-P-002).
- 6.1.4 Identify existing and future transmission system capacity needs.
- 6.1.5 Request desired normal and emergency ratings on planned facilities, and changes to existing facilities to Substation & Protection Engineering, and Transmission & Distribution Engineering.
- 6.1.6 Determine Facility Ratings based on most-limiting element comprising a facility.
- 6.1.7 Communicate established ratings to Substation & Protection Engineering, Transmission & Distribution Engineering, Operations Support, Reliability Center Operations, Electrical Maintenance, external utilities, and the Reliability Coordinator.
- 6.1.8 Maintain the Facility Ratings Update process.
- 6.1.9 Assume NERC Standard FAC-008-5 compliance reporting responsibilities.
- 6.1.10 Coordinate requests for information related to the BHC Facility Ratings Methodology (TP-P-002) with the appropriate BHC group and provide a response to the requesting entity within the required time frame.
- 6.1.11 Maintain element rating database (PTP spreadsheets)

6.2 Transmission & Distribution Engineering

- 6.2.1 Develop and maintain documentation of the assumptions, methods, and design criteria used in the determination of ratings for transmission facility equipment in accordance with FAC-008-5.
- 6.2.2 Determine ratings of system equipment in accordance with the BHC Facility Rating Methodology (TP-P-002).
- 6.2.3 Design new transmission line projects to meet desired capacity specified by Transmission Planning.
- 6.2.4 Design modifications to existing transmission lines to meet desired capacity specified by Transmission Planning.
- 6.2.5 Communicate with Transmission Planning any disparities between the requested capacity and actual achievable capacity of a new transmission line.
- 6.2.6 Address requests for conductor rating exceptions or deviations from standard practice.

6.3 Substation & Protection Engineering

- 6.3.1 Develop and maintain documentation of the assumptions, methods, and design criteria used in the determination of ratings for substation facility equipment in accordance with FAC-008-5.
- 6.3.2 Determine ratings of system equipment in accordance with the BHC Facility Rating Methodology (TP-P-002).
- 6.3.3 Design new projects to meet desired capacity specified by Transmission Planning.
- 6.3.4 Communicate with Transmission Planning any disparities between the requested capacity and actual achievable capacity of a new substation project.
- 6.3.5 Develop and maintain ratings one-line drawings for the documentation of new and existing terminal equipment ratings.
- 6.3.6 Coordinate with Electrical Maintenance on determining relay/metering limitations and CT ratios.
- 6.3.7 Coordinate and implement protection system setting changes associated with a change in facility ratings.
- 6.3.8 Address requests for equipment rating exceptions or deviations from standard practice.

6.4 Electrical Maintenance

- 6.4.1 Coordinate scheduled equipment changes with Reliability Center Operations.
- 6.4.2 Install equipment per design.

- 6.4.3 Increase relay/CT settings as requested to meet desired equipment ratings.
- 6.4.4 Replace or modify terminal equipment to meet desired equipment ratings.
- 6.4.5 Add or modify transmission structures to meet desired ratings.
- 6.4.6 Perform updates on the maintenance data repository as applicable.

6.5 Reliability Center / Operational Support

- 6.5.1 Observe and utilize proper facility ratings.
- 6.5.2 Update loading alarms and SCADA displays based on established facility ratings.
- 6.5.3 Notify Transmission Planning of real-time loading issues to be corrected.
- 6.5.4 Provide Transmission Planning with final approval for rating change requests.
- 6.5.5 Update BHC and external real-time models as necessary.

6.6 Power Delivery

- 6.6.1 Develop and maintain documentation of the assumptions, methods, and design criteria used in the determination of ratings for generators and generation facility equipment in accordance with FAC-008-5.
- 6.6.2 Maintain Generation Element Rating database of equipment ratings.
- 6.6.3 Provide generation facility equipment ratings to Transmission Planning, Reliability Center / Operational Support, and Substation & Protection Engineering.
- 6.6.4 Coordinate requested rating changes to generation facilities with Reliability Center / Operational Support, Transmission Planning, Electrical Maintenance, Transmission & Distribution Engineering, and Substation & Protection Engineering.

7 Facility Rating Process

The process for updating the BHC Transmission Facility Ratings is described in Appendix B.

8 Points of Contact

The appropriate contacts for each of the BHC groups identified in **Section 6** are shown in Error! Reference source not found..

9 Revision History

Rev.	Revision Date	Description	Revised By
1.0	5/14/07	BHP Facility Rating Methodology: New Document	EME
1.1	6/30/08	BHP Facility Rating Methodology: Updated generator and transmission line sections.	EME
1.0	7/14/09	BHCE Facility Rating Methodology: Converted to BHCE document from Aquila and changed conductor rating assumptions	EME
1.1	7/22/09	BHCE Facility Rating Methodology: Added “Relay Protective Devices” to “Terminal Equipment” section heading.	EME
1.2	6/29/12	BHCE Facility Rating Methodology: Added 30-min limit to Emergency Transformer Ratings of 125%. Added timeframes for overhead conductor seasonal ratings.	WRW
2.0	12/31/12	Combined BHP and BHCE Facility Rating Methodology documents into a single BHC document addressing the requirements of FAC-008-3.	WRW
2.1	1/9/13	Added Roles and Responsibilities section, Facility Rating Process in Appendix A, and Contacts section. Grammatical changes.	WRW, JK
2.2	7/30/13	Modified Flexible Substation Conductor description and included verbiage on equipment rated per manufacturer’s specifications on nameplates.	WRW, JK
2.3	11/27/13	Changed winter ambient temperature assumption to 10 °C. Combined duplicate sections for transmission facilities owned by the TO and GO.	WRW
2.4	12/29/14	Updated Section 5.1.	WRW
2.5	6/8/15	Added SME Review table, updated NERC Glossary reference, updated Section 5 assumptions and layout. Updated Section 4 content. Reworded Section 6.4.6.	WRW
2.6	6/1/18	Updated BHC contacts and subject matter experts. Added Summer and Winter reference dates to Table 5-1. Added comment in Section 5.2.1 that substation conductors assume 40°C ambient air temp year round.	WRW
2.7	11/18/2020	Updated generator ratings description. Updated section 5.2.1. to help clarify wind speed assumptions for different jumpers. Also, added sentence in 5.1.1 clarifying assumptions for transformer temp rise. Also, added Appendix A with facility details.	TR

3.0	2/9/2023	Addition of conductor temperature use in normal and emergency ratings in section 5.2 Bare Overhead Flexible Conductors. Addition of new table in section 5.2 and updated references to other tables. Addition of emergency ratings to section 5.3 Rigid Bus Conductors. Addition of section 5.5.1 Reasonability Limits of Instrumentation Transformers. Minor text updates from previous audit discussions.	MR
-----	----------	--	----

Appendix A

Facility Details

Summary: Transmission facilities include the transmission line conductor and the relevant terminal equipment as specified for each bus arrangement in the figures below. The relevant terminal equipment is highlighted in yellow for each example.

Figure 1A below demonstrates which terminal equipment will be considered for a transmission line facility that terminates at a breaker and half substation. Everything in the highlighted bubble would be considered for the facility rating of Line 1.

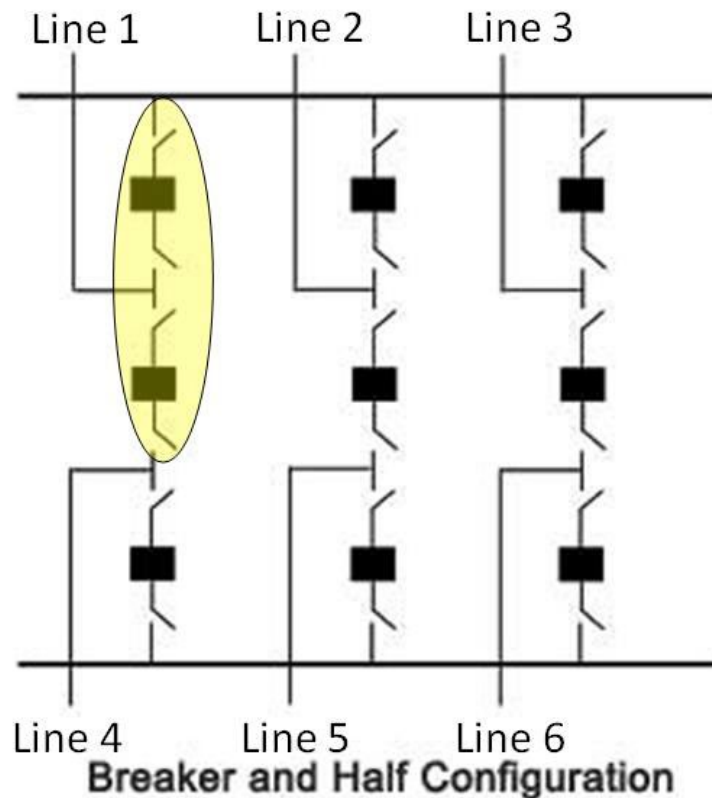

Figure 1A: Breaker and Half Terminal Equipment Considerations

Figure 2A below demonstrates which terminal equipment will be considered for a transmission line facility that terminates at a double bus double breaker substation. Everything in the highlighted bubble would be considered for the facility rating of Line 1.

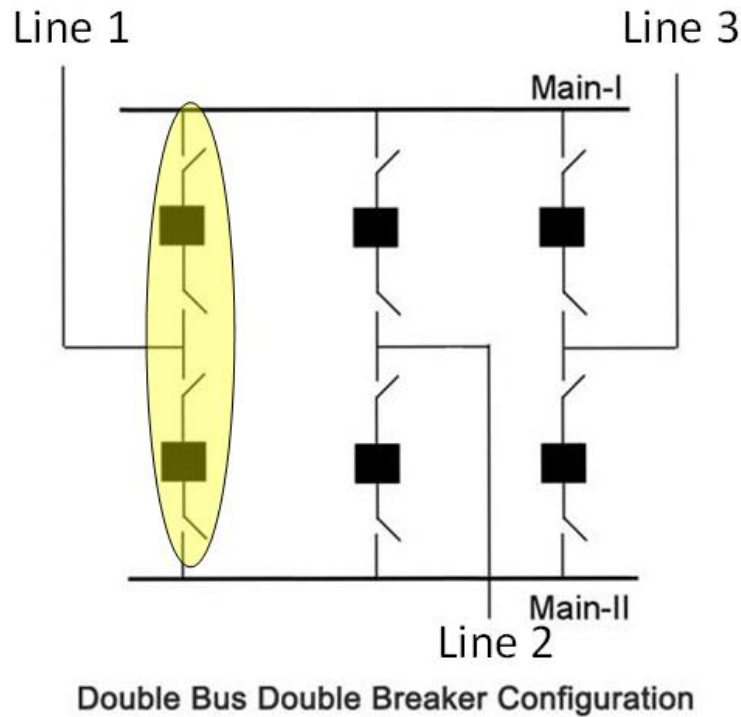

Figure 2A: Double Bus Double Breaker Terminal Equipment Considerations

Figure 3A below demonstrates which terminal equipment will be considered for a transmission line facility that terminates at a double bus single breaker substation. Everything in the highlighted bubble would be considered for the facility rating of Line 1.

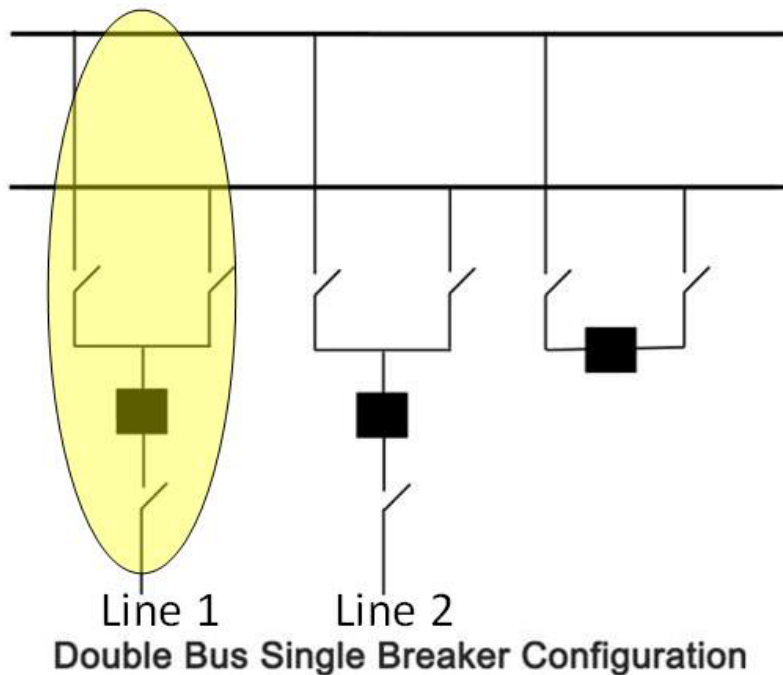

Figure 3A: Double Bus Single Breaker Terminal Equipment Considerations

Figure 4A below demonstrates which terminal equipment will be considered for a transmission line facility that terminates at a main and transfer substation. Everything in the highlighted bubble would be considered for the facility rating of Line 1.

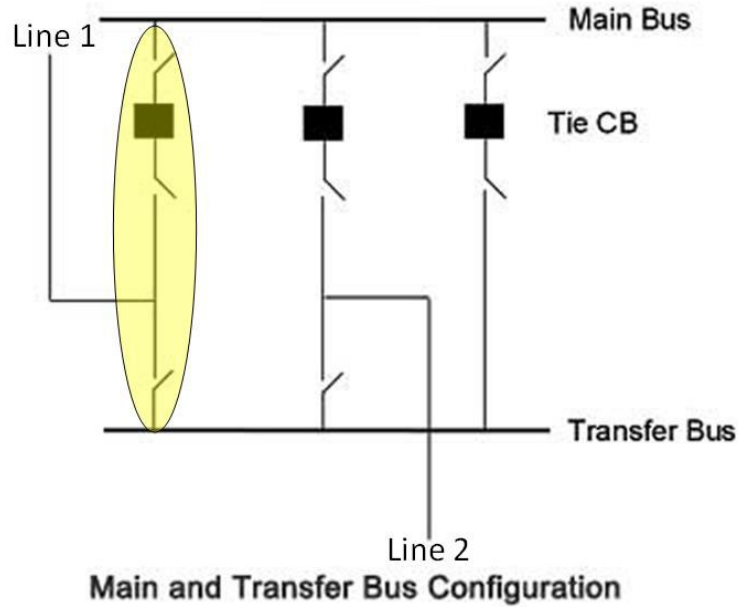
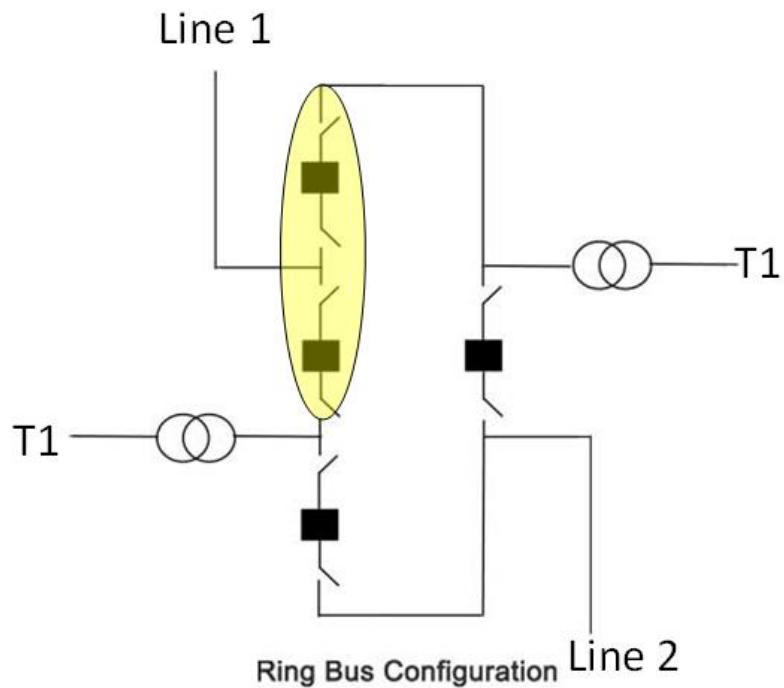

Figure 4A: Main and Transfer Bus Terminal Equipment Considerations

Figure 5A below demonstrates which terminal equipment will be considered for a transmission line facility that terminates at a ring bus substation. Everything in the highlighted bubble would be considered



for the facility rating of Line 1.

Figure 5A: Ring Bus Terminal Equipment Considerations

Figure 6A below demonstrates which terminal equipment will be considered for a transmission line facility that terminates at a single bus substation. Everything in the highlighted bubble would be considered for the facility rating of Line 2.

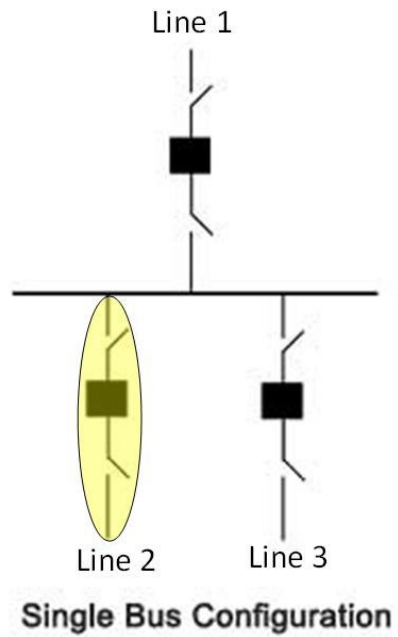

Figure 6A: Single Bus Terminal Equipment Consideration

Appendix B

Facility Rating Process

Black Hills Energy 2023 ERP Load Forecast Attachment LS-1, Section 4

Load Forecast

The starting point for ERP modeling and analysis is an annual peak and energy load forecast. This forecast, based on realistic assumptions about local population changes and local economic factors, determines the future demand the utility's resources will be required to meet.

The Plan employs an econometric forecasting methodology to forecast peak demand and energy. The Company gathered and refined a variety of different types of datasets, including historical load, economic, and weather data. This data was used to develop models for the monthly peak demand forecast and energy forecasts.

The final system-level monthly peak demand forecast was computed by adding large customer loads, including anticipated future load growth, the effects of DSM plans, and a net behind-the-meter ("BTM") solar forecast to the base load forecast produced from the regression analysis. The final system-level major customer class energy forecasts were computed by adding large customer loads, including their anticipated future load growth, losses, the effects of DSM plans, and a net BTM solar forecast to the base energy forecasts calculated through the regression analysis.

The Plan developed base, low, high, and increased electrification load forecasts, and includes system-level demand and major customer class energy forecasts using historical data.

4.1 Econometric Model Overview

Econometric modeling was used as the foundation for system level demand and major customer class energy forecasts. The econometric models were developed using the statistical software package Stata®. Black Hills used this software to develop statistical models that estimate the effect of various factors (e.g., weather) on customer sales, the number of customers served, and system peak demand. The explanatory factors used in these equations consist of weather, demographic variables, and economic variables.

The advantages of econometric forecasting models include:

- The ability to estimate effects of specific drivers on sales and demand, controlling for the effect of all other included variables. For example, the models estimate the effect of economic conditions on sales controlling for variations in weather conditions.
- The ability to refine and adapt the models to reflect changing circumstances over time.
- The use of third-party weather, economic, and demographic data in the forecast removes potential concerns about biased inputs.
- Providing measures of the statistical precision of the estimates, such as the statistical significance of particular driver variables or the overall explanatory power of the forecast model.

Econometric forecasting models reveal relationships between sales (or demand or the number of customers served) and economic or demographic variables to forecast future developments. The process begins by estimating the historical relationship between sales (or demand or the number of customers served) and the relevant drivers, which may include weather, economic conditions, demographic trends, or seasonal patterns. The resulting estimates of the relationship between each driver and the associated outcome (e.g., sales) are then applied to forecasts of the drivers to develop the forecast sales, demand, or number of customers served. The statistical models are reviewed and refined to ensure that the estimated relationships are reasonable (i.e., correctly signed and of reasonable magnitude).

4.2 Load, Economic, and Weather Data

As noted above, the Company uses historical load data (including information on large customers), economic data, and weather data as principal inputs into its load modeling. These data inputs are discussed in more detail below.

4.2.1 Historical Load Data

The Plan utilizes historical system-level hourly load data to develop the peak demand forecast. The Company identified one individual large customer whose load was removed from the historical load data before modeling. The Company excluded this customer's load from the historical data because it is a significant percentage of the Company's total load and is not expected to increase. Therefore, the Company did not want the growth rates calculated through the regression analysis applied to this large load. Black Hills subtracted this large customer's hourly peak data from the system historical data, creating a new "base" historical dataset. This "base" historical dataset was used in the regression analysis. The excluded data for the one large customer was added back into the demand forecast after the model runs were complete. Similarly, historical net BTM solar load was removed prior to modeling and was added back into the demand forecast after the model runs were complete.

The major customer class energy forecasts were developed using historic sales and customer count. Sales data by rate identification were gathered, reviewed, and aggregated into major customer classes based on the type of service (for example, residential, commercial, and industrial) as appropriate. Similar to the hourly load data, a base historical sales dataset was established by removing specific large customers and historical net BTM solar data. In addition, historical lighting service data and Company-usage data were removed before conducting the sales forecast regression analysis to ensure the customer class sales growth rates were not skewed by the historical growth patterns for these sectors. The excluded data for certain large customers, BTM solar load, lighting, and Company use were added to the aggregated sales forecast after the major class forecast regressions were complete.

The historical load and sales data used in the peak demand and sales models is included in Schedule B-1 and Schedule B-2, Appendix B, respectively.

4.2.2 Economic Data

Economic and demographic historical and forecast data were obtained from Woods & Poole Economics, Inc. (“W&P”) for Pueblo and Fremont Counties for the years 1969 through 2050. Though this dataset includes a variety of economic variables, Black Hills determined that the relevant variables for the Company’s load forecasts were persons per household, number of households, real household total personal income, total employment, gross regional product (“GRP”), and total personal income per-capita. Each of these variables was tested in the regression analysis.

The historical and forecasted economic data used in the peak demand and sales models are included in Schedule B-3, Appendix B.

4.2.3 Weather Data

Historical weather data was collected from the NOAA National Climatic Data Center’s (“NCDC”) Pueblo Airport weather station. The historical hourly temperature data was used to calculate heating degree days (“HDD”) and cooling degree days (“CDD”) using a 60 degree Fahrenheit threshold. The heating degree hours (“HDH”) and cooling degree hours (“CDH”) were calculated using 50 degree and 70 degree Fahrenheit thresholds, respectively. The HDD, CDD, HDH, and CDH data were used for both historical and normal weather forecasting purposes. The monthly CDD daily average was based upon the monthly average of total CDD; similarly, the monthly HDD daily average was based upon the monthly average of total HDD. The historical weather data used in the peak demand and sales models is included in Schedule B-4 and Schedule B-5, Appendix B respectively.

4.2.4 Normal Weather Conditions

The weather variables in the energy and demand forecasts are set to reflect “normal” conditions, which is interpreted as the average weather conditions over 20 years. In the energy model, the average of the sum of the cooling degree days over the available time period was used to calculate normal weather for each month. In the peak demand model, each month is determined to be either a predominantly cooling- or heating-peak month, and then only the relevant peak-hours for each month and year are averaged. Those averages are averaged again for each month and used as normalized peak weather conditions.

4.3 Forecast Methodology

Multiple combinations of the variables described above were tested in the development of the energy and demand forecasts. The models were refined to ensure that the estimates were logically reasonable (e.g., sales increase with CDDs) and statistically significant (or approaching statistical significance). Normal weather conditions are used to forecast energy and demand.

4.3.1 Peak Demand Forecast Methodology

The Company's system demand forecast is a system-level forecast inclusive of residential, commercial, industrial, and lighting sectors. Each month's peak hours from 2006 to 2020 were used to model the monthly peak demand forecast. The peak demand model was estimated using Ordinary Least Squares ("OLS"). The resulting estimates were used in combination with normal weather and forecasted economic conditions to forecast peak demands.

Summaries of the final equations, historical and forecasted values of variables used, and resulting forecasts for the demand model are provided in Schedules B-6 through B-9, Appendix B.

4.3.2 Energy Forecast Methodology

To complete the energy forecast, the Black Hills system was disaggregated into four major customer classes: residential, commercial small general service, commercial large general service, and industrial large power service. The residential customer class is an aggregation of all of Black Hills' residential rate identifications ("rate IDs"). The commercial classes include Black Hills' small and large general service rate IDs, and the Company's large power service rate IDs constitute the industrial class.

Summaries of the final equations, historical and forecasted values of variables used, and resulting forecasts for the energy models are provided in Schedules B-8 through B-25, Appendix B

4.3.3 Solar Distributed Generation

Net BTM solar amounts represent the forecasted customer's total usage less the customer's generated solar. To complete the net BTM solar demand forecast, a piece-wise growth rate was calculated using 2014-2020 historical hourly net BTM data, the Company's system load shape, and anticipated growth of future ITC adoption rates. This growth rate was applied to the previously excluded solar demand data to forecast forward.

To complete the net BTM solar energy forecast, previously excluded solar load was used to develop customer count and class-level UPC forecasts. The residential, small general service, and large general service customer models were estimated using a traditional OLS approach,

similar to the base energy forecast. The class-level UPC models were estimated using historical growth rate trends from 2006 through 2020. The customer count and UPC forecasts were multiplied together to produce the annual net-meter solar energy forecasts. These forecasts are then allocated across the 12 monthly periods in line with the expected solar irradiation levels across the geographic service territory. The Large Power Service net-meter solar energy forecast was produced by holding 2020 actual energy levels constant.

A detailed summary of the net BTM solar forecast, including the resulting demand and energy forecasts, are described in Appendix C.

4.3.4 Large Customer Growth Assumptions

The Company periodically reviews the growth plans of its largest customers in its service territory. These expected load increases can be uncertain and depend to a great extent on economic conditions. Table 4-1 shows anticipated large customer load additions and reductions (with confidence factor applied) for the RAP period 2022 through 2030. This information was compiled based on information gathered by the Company’s economic development personnel and adjusted by a confidence factor depending on the level of certainty expressed by the customer that the growth will actually occur. These annual changes in large customer loads are reflected in the peak demand and energy load forecasts.

**Table 4-1
 Large Customer Load Additions and Reductions 2022 - 2030**

Customer	Load Factor	2022 (MW)	2023 (MW)	2024 (MW)	2025 (MW)	2026 (MW)	2027 (MW)	2028 (MW)	2029 (MW)	2030 (MW)
Large Customer A	87%	1.0	0.0	-5.3	0.0	0.0	0.0	0.0	0.0	0.0
Large Customer B	32%	0.0	0.0	1.5	0.0	0.0	0.0	0.0	0.0	0.0
Large Customer C	50%	1.5	0.5	0.3	0.3	0.0	0.0	0.0	0.0	0.0
Large Customer D	50%	2.3	0.5	0.0	0.0	0.0	0.0	0.0	0.0	0.0
Large Customer E	45%	2.3	0.0	0.0	0.0	0.0	0.0	0.0	0.0	0.0

4.4 Base Peak Demand and Annual Energy Forecasts

The final base system-level monthly peak demand forecast was computed by adding the one large customer and anticipated future load growth of other large customers into the load forecast calculated by the regression analysis. Effects of DSM and the net BTM solar demand forecast were also added into the load forecast.

The final system-level major customer class energy forecasts were computed by adding large customer loads, including their anticipated future load growth, lighting service, Company-use, effects of DSM, transmission and distribution losses, and the net BTM solar energy forecast to the energy forecasts calculated through the regression analysis.

Combined transmission and distribution losses were also added into the annual energy forecast for each major customer class. Losses were estimated by calculating a weighted loss percentage for each aggregated major class. The class level transmission and distribution losses are shown in Table 4-2. Separate system loss estimates cannot be made for transmission and distribution because the forecast was not developed at the transmission and distribution voltage level. The peak demand and energy forecast values for the base load forecast are shown in Table 4-3.

**Table 4-2
 Combined Transmission and Distribution Losses**

Major Sales Class	Line Loss Class	Average Estimated Losses	Aggregated Customer Class Weighted Losses by Class	Non-aggregated Customer Class Sales Losses
Residential	Residential	5.506%		5.506%
Commercial	Large General Service - Primary	3.765%	5.352%	
	Large General Service - Secondary	5.506%		
	Small General Service	5.506%		
Industrial	Large Power Service - Primary	3.765%	3.820%	
	Large Power Service - Secondary	5.506%		
	Large Power Service - Transmission	2.210%		
Large Customer 1	Large Customer 1	3.765%		3.765%
Large Customer 2	Large Customer 2	3.765%		3.765%
Large Customer 3	Large Customer 3	2.210%		2.210%
Lighting		5.506%		5.506%
Company Use		5.506%		5.506%
Auxiliary	Total System		3.100%	
	Station Use			

**Table 4-3
 Base Load Forecast**

Year	Peak Demand* (MW)	Annual Energy* (MWh)	Losses (MWh)
2022	435.5	2,111,958	151,869
2023	441.7	2,109,386	152,056
2024	442.6	2,063,331	150,945
2025	448.5	2,075,814	151,605
2026	449.7	2,085,018	152,180
2027	450.8	2,094,518	152,778
2028	451.9	2,103,554	153,338
2029	453.0	2,112,511	153,890
2030	454.0	2,122,155	154,497
2031	455.0	2,131,721	155,097
2032	456.0	2,140,816	155,659
2033	456.9	2,150,224	156,245
2034	457.9	2,159,963	156,857
2035	458.8	2,169,263	157,434
2036	459.7	2,178,527	158,007
2037	460.5	2,188,144	158,607
2038	461.4	2,197,711	159,203
2039	462.2	2,206,829	159,763
2040	463.0	2,215,912	160,321
2041	463.7	2,225,370	160,909
2042	464.5	2,234,422	161,466
2043	465.2	2,243,467	162,022
2044	465.9	2,252,894	162,610
2045	466.6	2,261,897	163,165
2046	467.3	2,270,482	163,687
2047	468.0	2,279,057	164,209
2048	468.6	2,287,636	164,732
2049	469.3	2,296,224	165,258
2050	469.9	2,304,816	165,785

*Peak Demand and Annual Energy Forecast values includes impacts of DSM Plans and losses.

4.5 Low and High Forecasts

The base load forecast is assumed to represent the expected midpoint of possible future outcomes, meaning that a future year’s actual load may deviate from the midpoint projections. To evaluate the impact of these potential deviations, low, and high load forecasts were developed.

The Company prepared low and high load forecasts in addition to its base load forecast as required by Rule 3606(b). For the high and low load forecasts, the Company developed an 80 percent confidence interval band around the base demand and sales forecasts, using the economic estimator Gross Regional Product (“GRP”).

The peak demand model provided an estimate of the effect of changes in GRP on changes in peak demand, along with a standard error associated with the estimate. These two uncertainties (in GRP over time and in the estimated effect of GRP on peak demand) are combined to produce the confidence interval around the demand and sales forecasts. The specific steps used to develop the confidence interval are described in Appendix B.

4.6 Increased Electrification Forecast

The Increased Electrification forecast was developed by E3 and added to the base load forecast for analysis in the Increased Electrification scenario. Table 4-4 below shows the increased electrification scenario and the detailed breakdown of different load components, including vehicle electrification and building electrification. The electrification loads were taken from projections developed for the state of Colorado in Colorado’s Greenhouse Gas Pollution Reduction Roadmap and were downscaled based on the Company’s share of statewide load in 2019. Building and transportation electrification are expected to drive significant load growth in Colorado Electric’s system in the long term in this scenario. The system average annual growth rate is expected to be 2.1%. Total system load will reach 3,895 GWh by 2050, almost double of the current system load. Additional details for this forecast can be found in E3’s Technical Report (Appendix F).

**Table 4-4
 Increased Electrification Forecast**

Units: GWh	2022	2025	2030	2035	2040	2045	2050
Residential Space Heating	5.5	27.4	90.7	168.0	258.2	335.8	378.3
Commercial Space Heating	2.2	10.4	33.6	63.6	93.6	112.3	119.9
Residential Water Heating	1.1	6.4	29.7	59.7	81.6	95.3	104.3
Commercial Water Heating	0.4	2.1	7.2	14.9	22.5	27.9	31.3
LDV Charging	8.9	40.9	137.9	269.3	402.4	506.4	575.9
MHDV Charging	3.6	16.7	55.2	129.3	232.8	317.8	380.5
Total Building Electrification Load	9.2	46.2	161.2	306.2	455.9	571.2	633.8
Total Vehicle Electrification Load	12.5	57.6	193.0	398.6	635.1	824.2	956.4

The values for the base, low and high load forecasts, including the effects of DSM are shown in Table 4-5.

**Table 4-5
 Low, Base, and High Load Forecasts**

Year	Peak Demand (MW)			Energy (GWh)		
	Low	Base	High	Low	Base	High
2022	433.2	435.5	437.7	2,105	2,112	2,119
2023	437.3	441.7	446.2	2,096	2,109	2,122
2024	435.9	442.6	449.3	2,044	2,063	2,083
2025	439.7	448.5	457.5	2,049	2,076	2,102
2026	438.7	449.7	460.9	2,052	2,085	2,119
2027	437.7	450.8	464.2	2,054	2,095	2,136
2028	436.8	451.9	467.6	2,056	2,104	2,153
2029	435.7	453.0	470.9	2,058	2,113	2,169
2030	434.7	454.0	474.1	2,060	2,122	2,186
2031	433.7	455.0	477.4	2,062	2,132	2,204
2032	432.7	456.0	480.6	2,064	2,141	2,220
2033	431.7	456.9	483.8	2,067	2,150	2,238
2034	430.6	457.9	487.0	2,069	2,160	2,256
2035	429.6	458.8	490.1	2,071	2,169	2,273
2036	428.5	459.7	493.3	2,073	2,179	2,290
2037	427.5	460.5	496.4	2,076	2,188	2,308
2038	426.4	461.4	499.5	2,078	2,198	2,326
2039	425.3	462.2	502.5	2,080	2,207	2,343
2040	424.3	463.0	505.5	2,083	2,216	2,360
2041	423.2	463.7	508.6	2,085	2,225	2,378
2042	422.1	464.5	511.6	2,087	2,234	2,395
2043	421.0	465.2	514.5	2,090	2,243	2,412
2044	419.9	465.9	517.5	2,092	2,253	2,430
2045	418.8	466.6	520.5	2,094	2,262	2,447
2046	417.7	467.3	523.4	2,097	2,270	2,464
2047	416.6	468.0	526.3	2,099	2,279	2,480
2048	415.4	468.6	529.3	2,101	2,288	2,496
2049	414.3	469.3	532.2	2,104	2,296	2,513
2050	413.1	469.9	535.1	2,106	2,305	2,529

Table 4-6 shows the total system summer and winter peak demand forecast for each year of the Planning Period.

Table 4-6
Seasonal Peak Demand Load Forecast Comparison – Base, Low, and High
(including impacts of DSM Plans)

Year	Peak Summer Demand (MW)			Peak Winter Demand (MW)		
	Low	Base	High	Low	Base	High
2022	433.2	435.5	437.7	332.1	332.8	333.5
2023	437.3	441.7	446.2	334.4	335.8	337.1
2024	435.9	442.6	449.3	331.5	333.5	335.5
2025	439.7	448.5	457.5	335.6	338.2	340.9
2026	438.7	449.7	460.9	334.9	338.2	341.5
2027	437.7	450.8	464.2	334.2	338.1	342.1
2028	436.8	451.9	467.6	333.5	338.0	342.7
2029	435.7	453.0	470.9	332.8	338.0	343.2
2030	434.7	454.0	474.1	332.1	337.9	343.8
2031	433.7	455.0	477.4	331.4	337.7	344.3
2032	432.7	456.0	480.6	330.6	337.6	344.8
2033	431.7	456.9	483.8	329.9	337.5	345.3
2034	430.6	457.9	487.0	329.2	337.4	345.8
2035	429.6	458.8	490.1	328.5	337.2	346.2
2036	428.5	459.7	493.3	327.8	337.1	346.7
2037	427.5	460.5	496.4	327.0	336.9	347.1
2038	426.4	461.4	499.5	326.3	336.7	347.5
2039	425.3	462.2	502.5	325.6	336.6	347.9
2040	424.3	463.0	505.5	324.9	336.4	348.4
2041	423.2	463.7	508.6	324.1	336.2	348.7
2042	422.1	464.5	511.6	323.4	336.0	349.1
2043	421.0	465.2	514.5	322.7	335.8	349.5
2044	419.9	465.9	517.5	321.9	335.6	349.8
2045	418.8	466.6	520.5	321.2	335.3	350.2
2046	417.7	467.3	523.4	320.4	335.1	350.5
2047	416.6	468.0	526.3	319.7	334.9	350.9
2048	415.4	468.6	529.3	318.9	334.6	351.2
2049	414.3	469.3	532.2	318.2	334.4	351.5
2050	413.1	469.9	535.1	317.4	334.2	351.9

4.7 Historical Peak Demand and Annual Energy and Comparison to the 2016 ERP

The Company has historically experienced its annual peaks in the summer. Peak demand and annual energy for the period 2017-2021 are provided on Table 4-7. Since 2017, the summer peak has experienced an average annual growth rate of 0.62 percent, the winter peak has experienced an average annual declining growth rate of -0.24 percent, and the historical annual energy experienced an average annual declining growth rate of -0.04 percent.

**Table 4-7
 Historical Peak Demand and Annual Energy**

Year	Peak Demand				Annual Energy*		Summer Load Factor (%)	Winter Load Factor (%)
	Summer (MW)	Summer % Change	Winter (MW)	Winter % Change	GWh	% Change		
2017	398		299		2,055		58.95%	78.47%
2018	413	3.77%	291	-2.68%	2,125	3.37%	58.73%	83.35%
2019	422	2.18%	292	0.34%	2,104	-0.97%	56.92%	82.26%
2020	401	-4.98%	297	1.71%	2,052	-2.46%	58.42%	78.88%
2021	407	1.50%	296	-0.34%	2,051	-0.08%	57.52%	79.08%
Average Annual Growth (%)		0.62%		-0.24%		-0.04		

* Annual energy includes transmission and distribution losses.

A comparison of the peak demand and energy forecasts from the 2016 ERP and this 2022 ERP is shown in Table 4-8. In the 2016 ERP, the annual energy growth was projected at 0.82 percent over the 2016-2040 period, as compared to the 0.31 percent growth rate projection in the current plan over the 2022-2050 time period. The annual peak demand growth over the 2016-2040 period was forecasted at 0.44 percent in the 2016 ERP, compared to the peak demand 2022 ERP growth rate projected to be 0.27 percent, as shown in Table 4-8.

**Table 4-8
 Peak Demand and Energy Forecast Comparison**

Year	Annual Energy (GWh)		Peak Demand DSM (MW)	
	2016 ERP	2022 ERP	2016 ERP	2022 ERP
2016	2,037		395	
2017	2,066		395	
2018	2,085		394	
2019	2,124		397	
2020	2,156		401	
2021	2,157		401	
2022	2,145	2,112	397	435
2023	2,152	2,109	398	442
2024	2,174	2,063	401	443
2025	2,195	2,076	404	449
2026	2,216	2,085	406	450
2027	2,237	2,095	409	451
2028	2,259	2,104	411	452
2029	2,280	2,113	414	453
2030	2,301	2,122	416	454
2031	2,320	2,132	419	455
2032	2,338	2,141	421	456
2033	2,356	2,150	423	457
2034	2,375	2,160	426	458
2035	2,393	2,169	428	459
2036	2,411	2,179	430	460
2037	2,428	2,188	432	461
2038	2,444	2,198	435	461
2039	2,460	2,207	437	462
2040	2,477	2,216	439	463
2041		2,225		464
2042		2,234		464
2043		2,243		465
2044		2,253		466
2045		2,262		467
2046		2,270		467
2047		2,279		468
2048		2,288		469
2049		2,296		469
2050		2,305		470
2016 - 2040	0.82%		0.44%	
2022 - 2050		0.31%		0.27%

4.8 Energy and Capacity Sales to Other Utilities and Intra-Utility Energy and Capacity Sales and Losses

Pursuant to Rule 3606(a)(III), the Company must provide a forecast of annual energy and capacity sales to other utilities, in addition to capacity sales to other utilities at the time of coincident summer and winter peak demand. The Company does not have any energy or capacity contracts with other utilities and therefore has no data to provide.

Pursuant to Rule 3606(a)(IV), the Company must provide a forecast of annual intra-utility energy and capacity use at the time of coincident summer and winter peak demand. The Company does not have any intra-utility energy or capacity contracts and therefore has no data to provide.

4.9 Load Profiles

Typical day load patterns for Colorado Electric's system load presented for peak day, average day, and representative average off-peak days for each calendar month are provided in Appendix D. These monthly load shapes were developed from hourly system demand data for the year 2020 and reflect average customer use for the system.

Black Hills Energy 2015 Senate Bill 07-100 Report



2015 SENATE BILL 07-100 REPORT

**DESIGNATION OF ENERGY RESOURCE ZONES
AND
TRANSMISSION EXPANSION PLAN**

**BLACK HILLS/COLORADO ELECTRIC UTILITY COMPANY, L.P.,
D/B/A BLACK HILLS ENERGY**

PREPARED
BY
BLACK HILLS CORPORATION
TRANSMISSION PLANNING DEPT.

October 30, 2015

Table of Contents

- 1. Introduction..... 193**
- 1.1. Colorado Senate Bill 07-100..... 193
- 1.2. Stakeholder Participation..... 193
- 2. Designation of Energy Resource Zones..... 193**
- 2.1. Zone Identification Assumptions..... 193
- 2.2. Colorado-wide ERZ Identification 194
- 2.2.1. ERZ-2 via BHCE Nyberg 115 kV Substation 194
- 2.2.2. ERZ-4 via BHCE West Cañon 230 kV Substation..... 194
- 2.2.3. ERZ-5 via BHCE Rattlesnake Butte – Reader 115 kV line..... 194
- 3. Study Methodology 196**
- 3.1. Assumptions..... 196
- 3.2. Reliability Criteria 196
- 3.2.1. Steady State Voltage Criteria..... 197
- 3.2.2. Steady State Thermal Criteria..... 197
- 3.3. Study Area 197
- 3.4. Study Case Development..... 197
- 3.4.1. 2020 Study Cases..... 197
- 3.4.2. Resource Scenarios..... 198
- 4. Results..... 198**
- 4.1. ERZ-2 via BHCE Nyberg 115 kV substation..... 198
- 4.2. ERZ-4 via BHCE West Cañon 230 kV line..... 198
- 4.3. ERZ-5 via BHCE Rattlesnake Butte – Reader 115 kV line..... 198
- 4.4. Results Summary 199
- 5. Transmission System Expansion 199**
- 5.1. Terminal Equipment Hyde Park-West Station 115 kV line..... 200
- 5.2. Terminal Equipment Upgrades on Reader-Pueblo 115 kV line..... 200
- 5.3. Nyberg-Airport Memorial 115 kV line rebuild..... 200
- 5.4. West Cañon 230:115 kV transformer addition 200
- 5.5. West Station-West Cañon 115 kV transmission line..... 201
- 6. Ordinary Course of Business 201**
- 7. Conclusions..... 201**

Appendix A.....A-1
Appendix B.....B-1

List of Tables

Table 1: Black Hills Transmission System Interconnection Points.....197

List of Figures

Figure 1: Black Hills Colorado Energy and PSCo Energy Resource Zones195

1. Introduction

1.1. Colorado Senate Bill 07-100

On March 27, 2007, Colorado Senate Bill 07-100 (“SB-100”), codified at Colo. Rev. Stat. § 40-2-126(2), became effective. The purpose of the bill is to ensure that Colorado utilities “continually evaluate the adequacy of electric transmission facilities throughout the state” and “promptly and efficiently improve such infrastructure as required to meet the state’s existing and future energy needs.”

The bill specifically requires each Colorado electric utility that is subject to rate regulation by the Colorado Public Utilities Commission (“Commission”) to perform the following on or before October 31 of each odd-numbered year:

- (a) Designate Energy Resource Zones;
- (b) Develop plans for the construction or expansion of transmission facilities necessary to deliver electric power consistent with the timing of the development of beneficial energy resources located in or near such zones.
- (c) Consider how transmission can be provided to encourage local ownership of renewable facilities, whether through renewable energy cooperatives as provided in Colo. Rev. Stat. § 7-56-210, or otherwise; and
- (d) Submit proposed plans, designations, and applications for Certificates of Public Convenience and Necessity to the Commission for simultaneous review.

The requirement for a Certificate of Public Convenience and Necessity (“CPCN”) for a particular transmission project is governed by Colo. Rev. Stat. §§ 40-2-126 and 40-5-101 and by the process in Commission Rule 3206, 4 *Code of Colorado Regulations* 723-3.

1.2. Stakeholder Participation

Black Hills/Colorado Electric Utility Company, L.P., d/b/a Black Hills Energy (“Black Hills”) encouraged all interested parties to participate in the 2015 SB-100 study process. An open stakeholder SB-100 Kick-off Meeting was held in conjunction with the Q1 Black Hills Colorado Transmission (“BHCT”) Transmission Coordination and Planning Committee (“TCPC”) on March 20, 2015 to inform stakeholders of the proposed study plan and to provide an opportunity for suggestions and feedback on the study process. The Kick-off Meeting was attended via web conference by neighboring utilities, resource developers and Commission Staff. Follow-up web conferences were held on June 17, 2015 and October 8, 2015 to provide the stakeholders with updates to the study progress and provide further opportunities for input to the process. Meeting notices and presentations were distributed via email and posted on the Black Hills OASIS page at <http://www.oatioasis.com/bhct/index.html>.

2. Designation of Energy Resource Zones

2.1. Zone Identification Assumptions

An Energy Resource Zone (“ERZ”), as defined in Colo. Rev. Stat. § 40-2-126(1), is “a geographic area in which transmission constraints hinder the delivery of electricity to Colorado consumers, the development of new electric generation facilities to serve Colorado consumers, or both.” SB-100 requires utilities to identify ERZs and to “develop plans for the construction and expansion of transmission facilities necessary to deliver electric power from resources in or near such zones.” Colo. Rev. Stat. § 40-2-126(2).

2.2. Colorado-wide ERZ Identification

On November 24, 2008, Public Service Company of Colorado (“PSCo”) filed with the Commission an information report which identified its five ERZs within Colorado. Black Hills has adopted the PSCo-defined ERZs within Colorado. These are shown in **Figure 1**. Four of the PSCo-defined ERZs are located in close geographical proximity to the Black Hills system, specifically Zones 2, 3, 4 and 5. Of these, Black Hills has studied Zones 2, 4 and 5 in this report based interconnection requests and identified projects.

2.2.1. ERZ-2 via BHCE Nyberg 115 kV Substation

The Black Hills Nyberg 115 kV substation was selected to represent the interconnection of resources from ERZ-2 based upon recent activity in the Black Hills generator interconnection queue. Recently withdrawn requests with points of interconnection close to the Nyberg 115 kV substation include BHCT-G12 (60 MW), BHCT-G15 (35 MW), and BHCT-G16 (20 MW).

2.2.2. ERZ-4 via BHCE West Cañon 230 kV Substation

The CCPG San Luis Valley Joint Study Task force is currently evaluating the San Luis Valley transmission system and identifying potential upgrade alternatives primarily to improve reliability and limited generation export capacity. Where energy is delivered to the West Cañon 230 kV bus the import capability of the BHCE system is limited by the single 100 MVA 230:115 kV transformer. The BHCE 2015 Rule 3206 Report included the West Station – West Cañon 115 kV Conceptual Project. Although the primary purpose of this project is to improve the reliability in the Cañon City area, an additional benefit would be to increase the import capability of the BHCE system. Potential joint participation in this project was considered in the scope of San Luis Valley Study.

2.2.3. ERZ-5 via BHCE Rattlesnake Butte – Reader 115 kV line

The Busch Ranch I wind project, consisting of 29 MW of wind generation at a site located in Huerfano County approximately 30 miles south of Pueblo, CO began commercial service in October 2012. A single circuit 115 kV line connects the project site at the Rattlesnake Butte substation to the Black Hills transmission system at the Reader substation. Additional wind projects interconnecting at Rattlesnake Butte represent active generator interconnection requests in the Black Hills generator interconnection queue. The in-service dates for interconnection requests BHCT-11 (29 MW) and BHCT-18 (60 MW) are January 1, 2018 and October 1, 2016 respectively. Interconnection request BHCT-10 (29 MW) is currently in suspension until November 16, 2015 and without a decision to proceed may be removed from the queue.

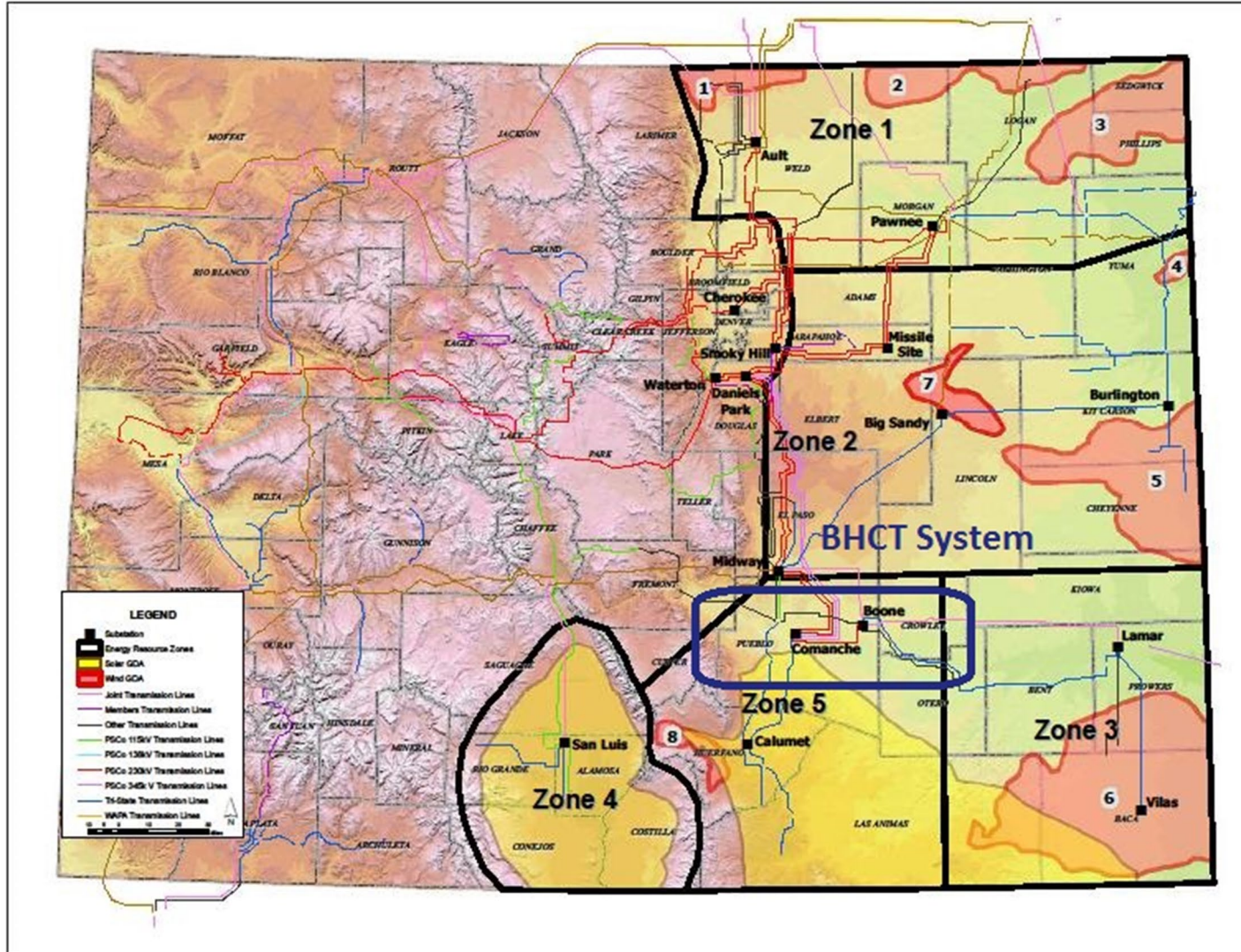

Figure 1: Black Hills Colorado Energy and PSCo Energy Resource Zones

3. Study Methodology

The SB-100 analysis was performed as a subset of the 2015 TCPC annual transmission assessment. The transmission system was evaluated under 2020 peak summer load levels to identify any significant adverse impact to the reliability and operating characteristics of the Western Electricity Coordinating Council (“WECC”) bulk transmission system and, more specifically, to the Black Hills and surrounding transmission systems. Steady state voltage and thermal analyses examined system performance without additional projects in order to establish a baseline for comparison. Performance was re-evaluated with resource injections modeled and compared to the baseline performance to determine the impact of the injections on area transmission reliability.

3.1. Assumptions

The analysis was performed with the following assumptions:

- All existing and planned facilities and the effects of control devices and protection systems were accurately represented in the system model.
- Projected firm transfers were represented per load and resource updates.
- Existing and planned reactive power resources were modeled to ensure adequate system performance.
- A list of the evaluated single contingency (N-1) outages is included in Appendix A. Multiple or extreme contingencies were not simulated in this study.
- The terminal equipment limitation on the Reader-Rattlesnake Buttes 115 kV line was assumed to be removed for this study because it is a prerequisite for any resources that would be developed and connected to the line.

The power flow analysis was performed with pre-contingency solution parameters that allowed adjustment of load tap-changing (“LTC”) transformers, static VAR devices including switched shunt capacitors and reactors, and DC taps. Post-contingency solution parameters allowed adjustment of DC taps and automatically switched shunt devices, as well as adjustment of manually switched shunt devices outside the study area. Area interchange control was disabled and generator VAR limits were applied automatically for all solutions. The solution method implemented was a fixed-slope decoupled Newton solution.

3.2. Reliability Criteria

The criteria described in this section are consistent with the new NERC TPL Reliability Standard (TPL-001-4), the WECC System Performance Regional Criterion (TPL-001-WECC-CRT-2.1) and Colorado Coordinated Planning Group’s Voltage Coordination Guide.

With respect to the new NERC TPL Reliability Standard (TPL-001-4) the system intact condition is now categorized as P0 rather than Category A (N-0) and a single contingency as P1 rather than Category B (N-1). Category C (N-2) multiple contingencies, equivalent to P2 – P7 contingencies under TPL-001-4 were simulated in this study.

3.2.1. Steady State Voltage Criteria

Under system intact conditions, steady state bus voltages must remain between 0.95 and 1.05 per unit. Following a Category B or C contingency, bus voltages must remain between 0.90 and 1.10 per unit. Pre-existing voltage violations outside the localized study area were ignored during the evaluation.

3.2.2. Steady State Thermal Criteria

All line and transformer loading must be less than 95% of their established continuous rating for system normal conditions (NERC/WECC Category A). All line and transformer loadings must be less than 95% of their established continuous or emergency rating under outage conditions (NERC/WECC Category B and C).

3.3. Study Area

The Black Hills transmission system follows the Arkansas River Valley from the Royal Gorge west of Cañon City to La Junta. The major load centers on the system are at Cañon City to the west, Rocky Ford to the east, and Pueblo in the center. A one line diagram of the Black Hills transmission system is included in Appendix B. Points of interconnection to the neighboring utilities are shown in **Table 1**.

Table 1: Black Hills Transmission System Interconnection Points

Interconnection Name	Interconnecting Utility ¹¹
Midway (PSCo)	PSCo
Midway (WAPA)	WAPA, CSU, Tri-State
Boone	PSCo, Tri-State
Reader	PSCo
Cañon West	WAPA, PSCo
West Station	Tri-State

3.4. Study Case Development

3.4.1. 2020 Study Cases

The 2020 heavy summer time frame was chosen for the near-term analysis for several reasons. The summer demand levels have historically been the most critical of the seasonal load patterns in the study area and the reduction in facility ratings due to the increased ambient temperatures during the summer months. The Colorado Coordinated Planning Group (CCPG) 2015 Compliance Study case (ccpg_2020hs_r4.sav) was used as the starting point for the 2020HS analysis. The case originated as a WECC 2020hs2ap approved base case.

Significant changes to the existing 2015 Black Hills transmission system to create the 2020 model included all projects listed in the most recent Colorado Rule 3206 filing (*See* Decision No. C15-0590 in Proceeding No.15M-0043E), as well as the addition of generation resources at Baculite Mesa proposed in the most

¹¹ “CSU” means Colorado Springs Utilities; “WAPA” means Western Area Power Administration and “Tri-State” means Tri-State Generation and Transmission Association, Inc.

recent Energy Resource Plan (*See* Docket No.13A-0445E). In all cases the Black Hills' loads were served by planned or existing Black Hills' generation.

3.4.2. Resource Scenarios

Resource injection alternatives to each benchmark case were evaluated to identify impacts to the existing transmission system. Incremental generation injections from ERZ-2 at Nyberg 115 kV substation, ERZ-4 West Cañon 115 kV substation and ERZ-5 at Rattlesnake Butte 115 kV substation were dispatched against Black Hills generation (Pueblo Airport Generating Station). The evaluation included the Busch Ranch (12 MW) wind projects represented by the generator interconnection queue requests (BHCT-G8, BHCT-G10 & BHCT-G11), which were modeled online in the benchmark cases. The baseline results assumed the flow on the Lamar DC Tie set at 0 MW East-West.

4. Results

4.1. ERZ-2 via BHCE Nyberg 115 kV substation

The 2020HS study results indicated the BHCE transmission system could accommodate a maximum injection of 250 MW from ERZ-2 via the BHCE Nyberg 115 kV substation without significant impacts to the system.

The Nyberg-Airport Memorial 115 kV line loading was 98% of its thermal limit for an injection of 250 MW following the N-1 loss of the Nyberg-Baculite Mesa 115 kV line. The Nyberg-Airport Memorial facility rating is limited by the line conductor to 119 MVA. Replacing the limiting substation and line conductor (5 miles of 336 ACSR 30/7 Oriole) would increase the facility rating of the line to 221 MVA, mitigating the observed near-overload.

4.2. ERZ-4 via BHCE West Cañon 230 kV line

The 2020HS study results indicated the BHCE transmission system could accommodate a maximum of 200 MW injection from ERZ-4 via the BHCE West Cañon 230-115 kV substation without significant impacts to the system.

The West Cañon 230-115 kV transformer loading was 100% of nameplate rating for an injection of 200 MW following the N-1 loss of the West Cañon-Midway (WAPA) 230 kV line. By replacing the West Cañon 230-115 kV transformer or adding a second transformer the maximum allowable injection from ERZ-4 increased to 330 MW. With the completion of the West Station-West Cañon 115 kV line the maximum allowable injection from ERZ-4 would increase to 400 MW assuming the transformer upgrade was completed.

4.3. ERZ-5 via BHCE Rattlesnake Butte – Reader 115 kV line

The 2018HS study results indicated the BHCE transmission system could accommodate a maximum of 219 MW injection from ERZ-5 via the Rattlesnake-Reader 115 kV line, due to the thermal limit of the transmission line. This includes any existing and requested wind generation resources at Rattlesnake Buttes.

The Pueblo Plant-Reader 115 kV line loading was 100% of its thermal limit for an injection of 219 MW following the N-1 loss of the Greenhorn-Reader 115 kV line. The Pueblo Plant-Reader facility rating is limited by terminal equipment (current transformers and wave traps) to 160 MVA. Replacing the limiting

equipment would increase the rating of the line to 182 MVA, mitigating the observed overloads. Also noted for the same contingency the Hyde Park-West Station 115 kV line loading was 96% of its thermal limit. The Hyde Park-West Station facility rating is limited by all the terminal equipment at West Station to 120 MVA. Constructing a new 115 kV line terminal at West Station would increase the rating of the line to 221 MVA.

The maximum allowable injection from ERZ-5 via the Reader-Rattlesnake Butte 115 kV line is 221 MW, due to a thermal limit of the transmission line (221 MVA). Although, some type of reactive power resource would be required at Reader 115 kV to compensate for reactive power absorbed by the single transmission line at this transfer limit.

4.4. Results Summary

The evaluated scenarios identified the maximum allowable resource injection from ERZ-2, ERZ-4 and ERZ-5, as well as the transmission system elements that limited such injections. Upgrades to the limiting transmission system elements often resulted in an increased injection capability. It is prudent to evaluate any identified upgrades in the context of resource needs and system capabilities.

The maximum allowable resource injection from ERZ-2 via the BHCE Nyberg 115 kV substation is 250 MW. By upgrading the Nyberg-Airport Memorial 115 kV line facility rating to 221 MVA, the maximum allowable injection from ERZ-2 increased to 420 MW.

The maximum allowable resource injection from ERZ-4 via the BHCE West Cañon 230-115 kV substation is 200 MW. By replacing the West Cañon 230-115 kV transformer or adding a second transformer the maximum allowable injection from ERZ-4 increased to 330 MW. With the completion of the West Station-West Cañon 115 kV line the maximum allowable injection from ERZ-4 would increase to 400 MW assuming the transformer upgrade was completed.

The maximum allowable resource injection from ERZ-5 via the Reader-Rattlesnake Butte 115 kV line is 219 MW. By upgrading the Reader-Pueblo 115 kV line and Hyde Park-West Station 115 kV line segments the maximum allowable injection from ERZ-5 increased to 221 MW, reflecting the thermal limit of the Reader-Rattlesnake Butte 115 kV line. Although, some type of reactive power resource would be required at Reader 115 kV to compensate for reactive power absorbed by the single transmission line at this transfer limit.

Considering these facts, Black Hills has identified one new transmission project, as well as previously identified projects which fulfill the objective of the reliable delivery of beneficial energy resources to customer loads. These projects are described in more detail in Section 5.

5. Transmission System Expansion

The following transmission projects have been identified by Black Hills as fulfilling the objectives of the reliable delivery of beneficial energy resources to customer load.

5.1. Terminal Equipment Hyde Park-West Station 115 kV line

The Pueblo-Hyde Park-West Station 115 kV line rebuild project was completed in 2013 and included 4.5 miles of upgraded transmission line. The facility rating of the Hyde Park-West Station section is limited by the terminal equipment at West Station to 120 MVA. A new 115 kV terminal at West Station would increase the facility rating to 221 MVA. The total estimated cost of this project is \$6.1M and includes the replacement of all limiting equipment for all line terminals in the legacy part of the substation. Estimated completion of this project is in 2018. This project will be described in Black Hills' next Rule 3206 Report (April 30, 2016).

5.2. Terminal Equipment Upgrades on Reader-Pueblo 115 kV line

The Reader-Pueblo 115 kV line is limited by terminal equipment (current transformers and wave traps) to 160 MVA. By removing the wave trap and current transformers limitations, the facility rating would increase to 182 MVA. This project is not expected to have any significant impact on noise or magnetic field levels at or near the Reader or Pueblo substations. This project will be designed to limit noise from the transmission facility to 50 d(B)A or less at the point of twenty-five feet from the edge of the property line or right-of-way and limit the magnetic field to 150 mG or less at the edge of the property line or right-of-way. The total estimated cost of this project is \$50,000. This project has not been formally proposed and no in-service date has been assigned.

5.3. Nyberg-Airport Memorial 115 kV line rebuild

The Nyberg-Airport Memorial 115 kV line is currently rated for 119 MVA, which is based upon thermal limit of the transmission line conductor (5 miles of 336 ACSR 30/7 Oriole). Replacing the limiting line and substation jumpers with 795 ACSR 26/7 Drake would increase the facility rating of the line to 221 MVA. This project is not expected to have any significant impact on noise or magnetic field levels at or near the Nyberg or Airport Memorial substations. This project will be designed to limit noise from the transmission facility to 50 d(B)A or less at the point of twenty-five feet from the edge of the property line or right-of-way and limit the magnetic field to 150 mG or less at the edge of the property line or right-of-way. The total estimated cost of this project is \$1,750,000. This project has not been formally proposed and no in-service date has been assigned.

5.4. West Cañon 230:115 kV transformer addition

The name plate rating of the West Cañon 230-115 kV transformer is 100 MVA, the addition of a second transformer would increase the import capacity and reliability of the BHCE system. This project is not expected to have any significant impact on noise or magnetic field levels at or near the West Cañon substation. This project will be designed to limit noise from the transmission facility to 50 d(B)A or less at the point of twenty-five feet from the edge of the property line or right-of-way and limit the magnetic field to 150 mG or less at the edge of the property line or right-of-way. It was assumed that there would be joint participation in the expansion of the West Cañon 230 kV substation related to the additional resources comprising the studied resource injection. The estimated cost to upgrade facilities owned by Black Hills is \$7,000,000. The preliminary cost estimate to upgrade facilities not owned by Black Hills was approximately \$5,000,000. These upgrades are conceptual in nature. This project has not been formally proposed and no in-service date has been assigned.

5.5. West Station-West Cañon 115 kV transmission line

The West Station-West Cañon 115 kV line is a conceptual project that was identified to increase reliability as well as local load service to the western portion of Black Hills’ service territory. This project has the added benefit of increasing the system’s capacity to deliver energy resources from ERZ-4 to Black Hills load. A prerequisite to realize that incremental capacity is the increase of transformation capacity at West Cañon as mentioned in Section 5.4. This project scope remains under development no cost estimate or in-service date has been assigned.

6. Ordinary Course of Business

Black Hills believes that the projects detailed in Sections 5.1, 5.2, 5.3 and 5.5 are in the ordinary course of its business for several reasons. They are replacements for various components of Black Hills’ existing transmission and/or distribution facilities. They will enhance the local load serving function and will improve reliability of service to our Colorado customers. These projects are similar in purpose to previous Black Hills’ 115 kV projects the Commission has previously determined were in the “ordinary course of business.” These transmission projects will provide increased reliability and long-term load serving capability for Black Hills customers. These projects will be part of the Black Hills base transmission infrastructure that is critical to the interconnection and delivery of capacity and energy from Black Hills’ potential beneficial energy resources.

The West Cañon 230/115 kV transformer addition/upgrade may be in the ordinary course of business if the existing transformer is replaced with a larger unit. However, if a second unit is added to the substation, an application for CPCN authority may be necessary, if determined by the Commission through the Rule 3206 review process.

7. Conclusions

Black Hills utilized an open and transparent process in conducting its 2015 Colorado Senate Bill 07-100 study. Stakeholders were provided several opportunities for involvement and input into the study process and scope. Through this process, Black Hills believes it has fulfilled the requirements of Colorado Senate Bill 07-100, codified at Colo. Rev. Stat. § 40-2-126.

Designate Energy Resource Zones.

On November 24, 2008, Public Service Company of Colorado (“PSCo”) filed with the Commission an information report which identified its five ERZs within Colorado. Four of the ERZs identified by PSCo are located in close geographical proximity to the Black Hills system, specifically Zones 2, 3, 4 and 5. In the 2011 SB-100 study report Black Hills identified two ERZs (ERZ #1 & ERZ #2), both of which were located within the PSCo defined ERZ-5. In order to avoid confusion Black Hills has adopted the five PSCo defined ERZs within Colorado.

Develop plans for the construction or expansion of transmission facilities necessary to deliver electric power consistent with the timing of the development of beneficial energy resources located in or near such zones.

Black Hills identified the impacts of the various resource scenarios on the Black Hills transmission system and identified projects which ensure reliable delivery of beneficial energy resources from the designated ERZ-2, ERZ-4 and ERZ-5 to customer loads.

Consider how transmission can be provided to encourage local ownership of renewable facilities, whether through renewable energy cooperatives as provided in Colo. Rev. Stat. § 7-56-210, or otherwise.

The proposed transmission projects will facilitate renewable resource development in ERZ-2, ERZ-4 and ERZ-5 in excess of what can be accommodated by the existing Black Hills transmission system.

Submit proposed plans, designations, and applications for Certificates of Public Convenience and Necessity to the Commission for simultaneous review.

Black Hills believes that the transmission projects it has identified to facilitate the reliable delivery of beneficial energy resources to customer load are “in the ordinary course of its business” and do not require CPCNs, pursuant to Colo. Rev. Stat. §§ 40-2-126(3) and 40-5-101. The reasons as to why these projects are “in the ordinary course of its business” and should not require CPCNs are detailed in Section 5 of this Report.

Appendix A

Power Flow Analysis: Single Contingency (N-1) Outage List

**Black Hills/Colorado Electric Utility Company, LP
2022 Rule 3627 Report – Appendix N – Black Hills Supporting Documents**

Standard TPL-001-4 Transmission System Planning Performance Requirement (P1 Single Contingency)									
P1.1 GENERATOR		P1.2 TRANSMISSION CIRCUIT		P1.3 TRANSFORMER		P1.4 SHUNT DEVICE		P1.5 SINGLE POLE OF A DC LINE	
LABEL	DESCRIPTION	LABEL	DESCRIPTION	LABEL	DESCRIPTION	LABEL	DESCRIPTION	LABEL	DESCRIPTION
P1-1-1	PP MINE G1	P1-2-115-1	MIDWAY(WAPA)-DESERT COVE***	P1-3-115-1	AREQUA GULCH 115-69 T1	P1-4-115-1	AREQUA GULCH		NONE
P1-1-2	E CANON G1	P1-2-115-2	DESERT COVE-WEST STATION	P1-3-115-2	AREQUA GULCH 115-69 T2	P1-4-115-2	CANON CITY		
P1-1-3	PUB-DSLS G1	P1-2-115-3	MIDWAY(PSCO)-WEST STATION	P1-3-115-3	BACULITE MSA GEN3 U1 *	P1-4-115-3	PORTLAND		
P1-1-4	RF-DSLS G1	P1-2-115-4	MIDWAY(PSCO)-BACULITE MESA***	P1-3-115-4	BACULITE MSA GEN4 U1 *	P1-4-115-4	WEST CANON		
P1-1-5	APT-DSLS G1	P1-2-115-5	BACULITE MESA-WEST STATION-1	P1-3-115-5	BOONE 115-69 T1	P1-4-115-5	(TSGT) LAMAR CO		
P1-1-6	BAC-MSA GEN1 G1	P1-2-115-6	BACULITE MESA-WEST STATION-2	P1-3-115-6	CANON CITY 115-69 T1	P1-4-115-6	(TSGT) WILLOW CREEK		
P1-1-7	BAC-MSA GEN2 G1	P1-2-115-7	HYDE PARK-WEST STATION	P1-3-115-7	LAJUNTAW 115-69 T1	P1-4-115-7	(TSGT) LAJUNTA		
P1-1-8	BAC-MSA GEN3 G1 & ST1*	P1-2-115-8	HYDE PARK-PUEBLO	P1-3-115-8	LAJUNTAW 115-69 T2				
P1-1-9	BAC-MSA GEN3 G2 & ST1*	P1-2-115-9	PUEBLO-READER	P1-3-115-9	PORTLAND 115-69 T1				
P1-1-10	BAC-MSA GEN3 ST1	P1-2-115-10	PORTLAND-WEST STATION-1	P1-3-115-10	PORTLAND 115-69 T2				
P1-1-11	BAC-MSA GEN4 G1 & ST1*	P1-2-115-11	PORTLAND-WEST STATION-2	P1-3-115-11	READER 115-69 T1				
P1-1-12	BAC-MSA GEN4 G2 & ST1*	P1-2-115-12	WEST STATION-STEM BEACH***	P1-3-115-12	READER 115-69 T2				
P1-1-13	BAC-MSA GEN4 ST1	P1-2-115-13	BURNT MILL-WEST STATION	P1-3-115-13	WEST STATION 115-69 T1				
P1-1-14	BAC-MSA GEN5 G1	P1-2-115-14	BURNT MILL-GREENHORN	P1-3-115-14	WEST STATION 115-69 T2				
P1-1-15	BUSCH RANCH WPP-1	P1-2-115-15	GREENHORN-READER	P1-3-115-15	(TSGT) WILLOW CREEK T1				
P1-1-16	BUSCH RANCH WPP-2	P1-2-115-16	READER-AIRPORT MEMORIAL	P1-3-115-16	(TSGT) WILLOW CREEK T2				
P1-1-17	BUSCH RANCH WPP-3	P1-2-115-17	AIRPORT PARK-AIRPORT MEMORIAL	P1-3-115-17	(TSGT) LAJUNTA T2				
P1-1-18	COMANCHE C1	P1-2-115-18	AIRPORT PARK-BACULITE MESA	P1-3-115-18	(TSGT) VILAS T1				
P1-1-19	COMANCHE C2	P1-2-115-19	NYBERG-AIRPORT MEMORIAL						
P1-1-20	COMANCHE C3	P1-2-115-20	NYBERG-BACULITE MESA						
P1-1-21	COMANCHE PV	P1-2-115-21	NYBERG-BOONE***						
P1-1-22	LAMAR DC TIE	P1-2-115-22	NYBERG-BOONE						
P1-1-23	TWIN BUTTE W1	P1-2-115-23	BOONE-LAJUNTA(BHCE)						
P1-1-24	COLORADO GREEN E W1	P1-2-115-24	BOONE-LAJUNTA(TSGT)						
P1-1-25	COLORADO GREEN W W2	P1-2-115-25	COMANCHE-READER-1						
P1-1-26	FOUNTAIN VALLEY G1	P1-2-115-26	COMANCHE-READER-2						
P1-1-27	FOUNTAIN VALLEY G2	P1-2-115-27	PORTLAND-SKALA						
P1-1-28	FOUNTAIN VALLEY G3	P1-2-115-28	CANON CITY-SKALA						
P1-1-29	FOUNTAIN VALLEY G4	P1-2-115-29	CANON CITY-WEST CANON						
P1-1-30	FOUNTAIN VALLEY G5	P1-2-115-30	AREQUA GULCH-WEST CANON						
P1-1-31	FOUNTAIN VALLEY G6	P1-2-115-31	PONCHA-WEST CANON						
P1-1-32	JACKSON FULLER W1	P1-2-115-32	READER-RATTLESNAKE BUTTE						
P1-1-33	JACKSON FULLER W2	P1-2-115-33	(TSGT) LAJUNTAT-WILLOW CRK						
P1-1-34	SLVSOLAR S1	P1-2-115-34	(TSGT) LAMAR CO-WILLOW CRK						
P1-1-35	SLV-SOLAR S1	P1-2-115-35	(TSGT) LAMAR CO-VILAS						
P1-1-36	SOLAR GE S2	P1-2-115-36	MIDWAY(WAPA)-GEESEN(TSGT)**						
P1-1-37	SOLAR GE S3	P1-2-115-37	MIDWAY(WAPA)-NIXON(CSU)						
P1-1-38	NIXON ROAD C1								
		P1-2-230-1	(PSCO) LAMAR CO-BOONE	P1-3-230-1	(WAPA) MIDWAYBR T1				
		P1-2-230-2	(PSCO) BOONE-MIDWAY	P1-3-230-2	(PSCO) MIDWAYPS T1				
		P1-2-230-3	(PSCO) BOONE-COMANCHE	P1-3-230-3	(BHCE) WEST CANON T1				
		P1-2-230-4	(PSCO) COMANCHE-MIDWAYPS 1	P1-3-230-4	(PSCO) PONCHA T1				
		P1-2-230-5	(PSCO) COMANCHE-MIDWAYPS 2	P1-3-230-5	(TSGT) WALSENBURG T2				
		P1-2-230-6	COMANCHE(PSCO)-WALSENBURG (TSGT)	P1-3-230-6	(TSGT) WALSENBURG T3				
		P1-2-230-7	(TSGT) WALSENBURG-GLADSTONE	P1-3-230-7	(PSCO) COMANCHE T1				
		P1-2-230-8	PONCHA(WAPA)-SAN LUIS VALLEY (PSCO)	P1-3-230-8	(PSCO) COMANCHE T2				
		P1-2-230-9	(WAPA) PONCHABR-CURECANT	P1-3-230-9	(TSGT) GLADSTONE T1				
		P1-2-230-10	(WAPA) PONCHABR-WEST CANON	P1-3-230-10	(TSGT) GLADSTONE T2				
		P1-2-230-11	PONCHA(WAPA)-PONCHA(PSCO)	P1-3-230-11	(PSCO) BOONE T1				
		P1-2-230-12	(WAPA) WEST CANON-MIDWAYBR	P1-3-230-12	(TSGT) LAMAR T1				
		P1-2-230-13	MIDWAY(WAPA)-NIXON(CSU)	P1-3-230-13	(TSGT) LAMAR T2				
		P1-2-230-14	(PSCO) MIDWAY-JACKSON FULLER						
		P1-2-230-15	(PSCO) JACKSON FULLER-DANIELS PARK						
		P1-2-345-1	(PSCO) MIDWAYPS-WATERTON	P1-3-345-1	(PSCO) COMANCHE T3				
		P1-2-345-2	(PSCO) COMANCHE-DANIELS PARK 1	P1-3-345-2	(PSCO) COMANCHE T4				
		P1-2-345-3	(PSCO) COMANCHE-DANIELS PARK 2	P1-3-345-3	(PSCO) DANIELS PARK T2				
				P1-3-345-4	(PSCO) DANIELS PARK T3				
				P1-3-345-5	(PSCO) DANIELS PARK T4				

Appendix B

Black Hills Transmission System One Line Diagram

2015 SB-100 Resource Injection Points

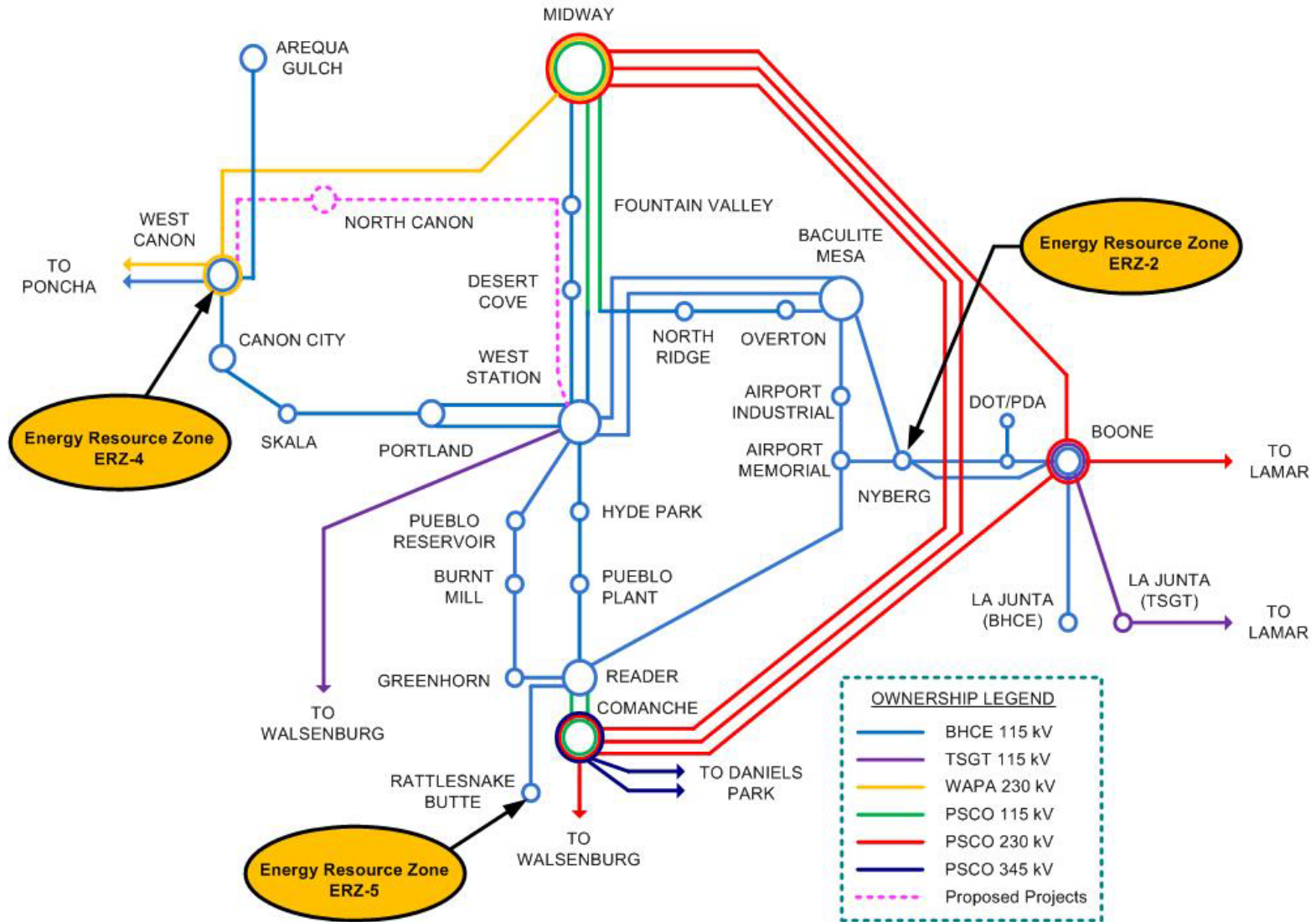

Black Hills Energy 2017 Senate Bill 07-100 Report



2017 SENATE BILL 07-100 REPORT

COMPLIANCE WITH ¶ 40-2-126 C.R.S.

**DESIGNATION OF ENERGY RESOURCE ZONES
AND
TRANSMISSION EXPANSION PLAN**

**BLACK HILLS/COLORADO ELECTRIC UTILITY COMPANY, L.P.,
D/B/A BLACK HILLS ENERGY**

PREPARED
BY
BLACK HILLS CORPORATION
TRANSMISSION PLANNING DEPT.

January 2, 2018

Table of Contents

1.	Introduction.....	210
1.1.	Colorado Senate Bill 07-100.....	210
1.2.	Stakeholder Participation.....	210
2.	Designation of Energy Resource Zones.....	210
2.1.	Zone Identification Assumptions.....	210
2.2.	Colorado-wide ERZ Identification	211
2.2.1.	ERZ-5 via Boone – Walsenburg 230 kV line	211
3.	Study Methodology.....	213
3.1.	Assumptions.....	213
3.2.	Reliability Criteria	213
3.2.1.	Steady State Voltage Criteria.....	213
3.2.2.	Steady State Thermal Criteria.....	213
3.3.	Study Area	214
3.4.	Study Case Development.....	214
3.4.1.	2027 Study Cases.....	214
3.4.2.	Resource Scenarios	214
4.	Results.....	214
4.1.	ERZ-5 via Boone – Walsenburg 230 kV line	214
4.2.	Results Summary	215
5.	Transmission System Expansion	215
5.1.	Terminal Equipment Upgrades on Reader-Pueblo 115 kV line.....	215
5.2.	Desert Cove-Fountain Valley-Midway 115 kV transmission line rebuild.....	215
5.3.	Boone-Rattlesnake Butte-Walsenburg 230 kV line.....	216
6.	Ordinary Course of Business	216
7.	Conclusions.....	216

List of Tables

Table 1:	Black Hills Transmission System Interconnection Points.....	197
----------	---	-----

List of Figures

Figure 1:	Black Hills Colorado Energy and PSCo Energy Resource Zones	195
-----------	--	-----

8. Introduction

8.1. Colorado Senate Bill 07-100

On March 27, 2007, Colorado Senate Bill 07-100 (“SB-100”), codified at Colo. Rev. Stat. § 40-2-126(2), became effective. The purpose of the bill is to ensure that Colorado utilities “continually evaluate the adequacy of electric transmission facilities throughout the state” and “promptly and efficiently improve such infrastructure as required to meet the state’s existing and future energy needs.”

The bill specifically requires each Colorado electric utility that is subject to rate regulation by the Colorado Public Utilities Commission (“Commission”) to perform the following on or before October 31 of each odd-numbered year:

- (e) Designate Energy Resource Zones;
- (f) Develop plans for the construction or expansion of transmission facilities necessary to deliver electric power consistent with the timing of the development of beneficial energy resources located in or near such zones.
- (g) Consider how transmission can be provided to encourage local ownership of renewable facilities, whether through renewable energy cooperatives as provided in Colo. Rev. Stat. § 7-56-210, or otherwise; and
- (h) Submit proposed plans, designations, and applications for Certificates of Public Convenience and Necessity to the Commission for simultaneous review.

The requirement for a Certificate of Public Convenience and Necessity (“CPCN”) for a particular transmission project is governed by Colo. Rev. Stat. §§ 40-2-126 and 40-5-101 and by the process in Commission Rule 3206, 4 *Code of Colorado Regulations* 723-3.

8.2. Stakeholder Participation

Black Hills/Colorado Electric Utility Company, L.P., d/b/a Black Hills Energy (“Black Hills”) encouraged all interested parties to participate in the 2017 SB-100 study process. An open stakeholder SB-100 Kick-off Meeting was held in conjunction with the Q1 Black Hills Colorado Transmission (“BHCT”) Transmission Coordination and Planning Committee (“TCPC”) on March 30, 2017 to inform stakeholders of the proposed study plan and to provide an opportunity for suggestions and feedback on the study process. The Kick-off Meeting had no external participants. Follow-up web conferences were held on June 27, 2017 and October 18, 2017 to provide the stakeholders with updates to the study progress and provide further opportunities for input to the process. Meeting notices and presentations were distributed via email and posted on the Black Hills OASIS page at <http://www.oatioasis.com/bhct/index.html>.

9. Designation of Energy Resource Zones

9.1. Zone Identification Assumptions

An Energy Resource Zone (“ERZ”), as defined in Colo. Rev. Stat. § 40-2-126(1), is “a geographic area in which transmission constraints hinder the delivery of electricity to Colorado consumers, the development of new electric generation facilities to serve Colorado consumers, or both.” SB-100 requires utilities to

identify ERZs and to “develop plans for the construction and expansion of transmission facilities necessary to deliver electric power from resources in or near such zones.” Colo. Rev. Stat. § 40-2-126(2).

9.2. Colorado-wide ERZ Identification

On November 24, 2008, Public Service Company of Colorado (“PSCo”) filed with the Commission an information report which identified its five ERZs within Colorado. Black Hills has adopted the PSCo-defined ERZs within Colorado. These are shown in **Figure 1**. Four of the PSCo-defined ERZs are located in close geographical proximity to the Black Hills system, specifically Zones 2, 3, 4 and 5. Of these, Black Hills has studied Zone 5 in this report based interconnection requests and identified projects.

9.2.1. ERZ-5 via Boone – Walsenburg 230 kV line

Tri-State Generation and Transmission Association, Inc. (“Tri-State” or “TSG&T”) previously identified a potential 230 kV line that would connect the existing Boone substation, owned by TSG&T and PSCo, to the Walsenburg substation, owed by TSG&T. The purpose of the project at the time was to improve the reliability in the Pueblo, Colorado area and to eliminate the need for the existing Walsenburg Remedial Action Scheme. Since the Busch Ranch and Peak View wind projects are located close to that potential transmission path, approximately 20 miles from Walsenburg, the opportunity would exist to interconnect additional wind resources in ERZ-5. In this analysis, the new 230 kV facilities would directly interconnect with the Black Hills Rattlesnake Butte 115 kV substation via a 230/115 kV transformer and new additional renewable energy sources connected to the 230 kV bus as part of the substation.

This scenario was considered as part of the 2013 SB-100 study. Due to several changes and upgrades to the transmission system since 2013, it was desired to reevaluate the scenario as part of the 2017 SB-100 analysis.

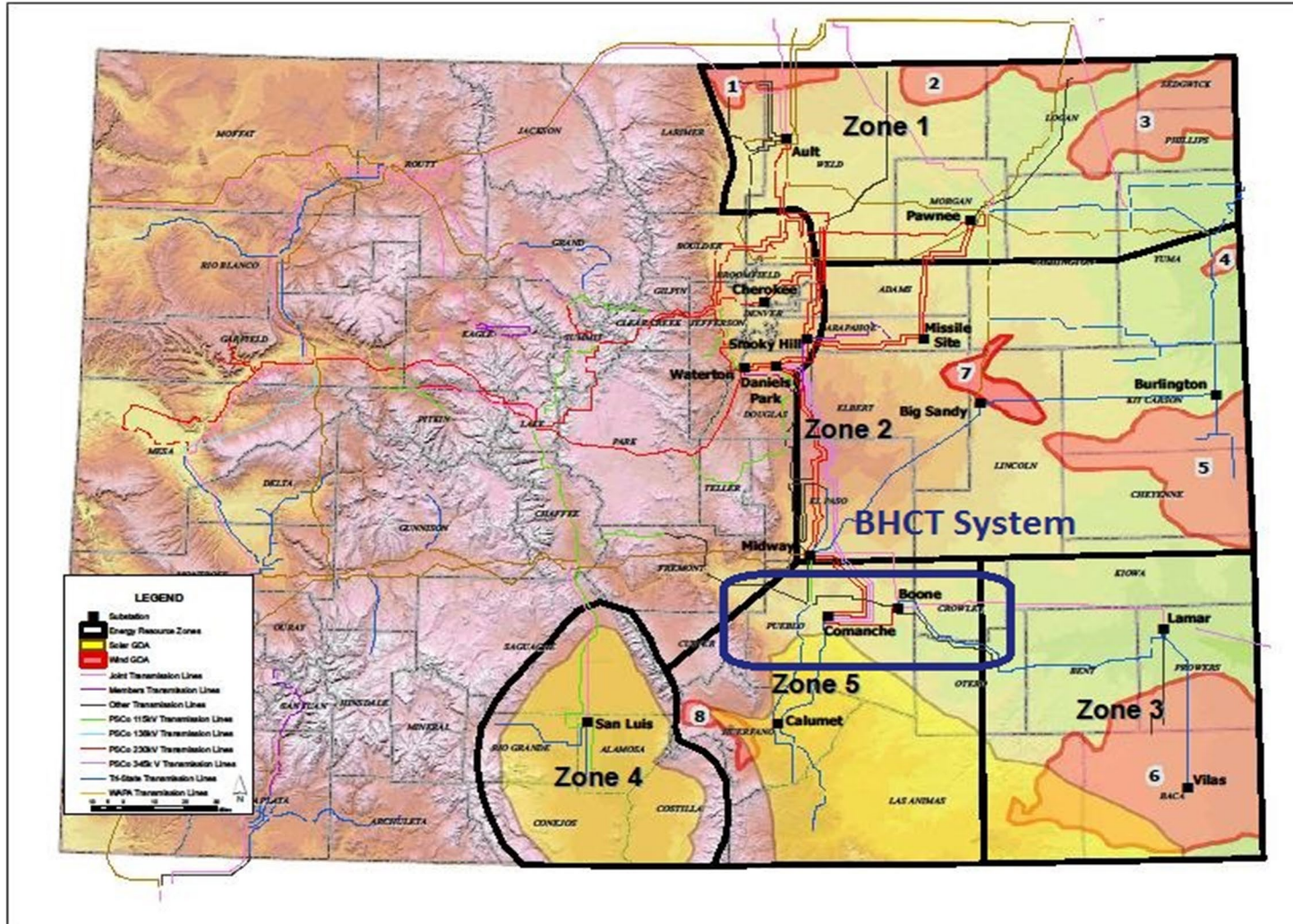

Figure 2: Black Hills Colorado Energy and PSCo Energy Resource Zones

10. Study Methodology

The SB-100 analysis was performed as a subset of the 2017 TCPC annual transmission assessment. The transmission system was evaluated under 2027 peak summer load levels to identify any significant adverse impact to the reliability and operating characteristics of the Western Electricity Coordinating Council (“WECC”) bulk transmission system and, more specifically, to the Black Hills and surrounding transmission systems. Steady state voltage and thermal analyses examined system performance without additional projects in order to establish a baseline for comparison. Performance was re-evaluated with resource injections modeled and compared to the baseline performance to determine the impact of the injections on area transmission reliability.

10.1. Assumptions

The analysis was performed with the following assumptions:

- All existing and planned facilities and the effects of control devices and protection systems were accurately represented in the system model.
- Projected firm transfers were represented per load and resource updates.
- Existing and planned reactive power resources were modeled to ensure adequate system performance.
- A list of the evaluated contingencies P1 and P7 are included in Appendix A. Extreme contingencies were not simulated in this study.
- The terminal equipment limitation on the Reader-Rattlesnake Buttes 115 kV line was assumed to be removed for this study because it is a prerequisite for any resources that would be developed and connected to the line.

The power flow analysis was performed with pre-contingency solution parameters that allowed adjustment of load tap-changing (“LTC”) transformers, static VAR devices including switched shunt capacitors and reactors, and DC taps. Post-contingency solution parameters allowed adjustment of DC taps and automatically switched shunt devices, as well as adjustment of manually switched shunt devices outside the study area. Area interchange control was disabled and generator VAR limits were applied immediately for all solutions. The solution method implemented was a fixed-slope decoupled Newton solution.

10.2. Reliability Criteria

The criteria described in this section are consistent with the new NERC TPL Reliability Standard (TPL-001-4), the WECC System Performance Regional Criterion (TPL-001-WECC-CRT-3) and Colorado Coordinated Planning Group’s Voltage Coordination Guide.

10.2.1. Steady State Voltage Criteria

Under system intact conditions P0, steady state bus voltages must remain between 0.95 and 1.05 per unit. Following Category P1 thru P7 contingencies, bus voltages must remain between 0.90 and 1.10 per unit. Pre-existing voltage violations outside the localized study area were ignored during the evaluation.

10.2.2. Steady State Thermal Criteria

All line and transformer loading must be less than 100% of their established continuous rating for system normal conditions (NERC/WECC Category P0). All line and transformer loadings must be less than 100%

of their established continuous or emergency rating under outage conditions (NERC/WECC Category P1-P7).

10.3. Study Area

The Black Hills transmission system follows the Arkansas River Valley from the Royal Gorge west of Cañon City to La Junta. The major load centers on the system are at Cañon City to the west, Rocky Ford to the east, and Pueblo in the center. A one line diagram of the Black Hills transmission system is included in Appendix B. Points of interconnection to the neighboring utilities are shown in **Table 1**.

Table 2: Black Hills Transmission System Interconnection Points

Interconnection Name	Interconnecting Utility ¹²
Midway (PSCo)	PSCo
Midway (WAPA)	WAPA, CSU, Tri-State
Boone	PSCo, Tri-State
Reader	PSCo
Cañon West	WAPA, PSCo
West Station	Tri-State

10.4. Study Case Development

10.4.1. 2027 Study Cases

The 2027 heavy summer time frame was chosen for the far-term analysis for several reasons. The summer demand levels have historically been the most critical of the seasonal load patterns in the study area and the reduction in facility ratings due to the increased ambient temperatures during the summer months. The Colorado Coordinated Planning Group (CCPG) 2017 Compliance Study 2027HS case was used as the starting point for the 2027HS analysis.

Significant changes to the existing 2017 Black Hills transmission system to create the 2027 model included all projects listed in the most recent Colorado Rule 3206 filing (*See* Proceeding No. 17M-005E). In all cases the Black Hills’ loads were served by planned or existing Black Hills’ generation.

10.4.2. Resource Scenarios

Resource injection alternatives to each benchmark case were evaluated to identify impacts to the existing transmission system. Incremental generation injections from ERZ-5 at the Rattlesnake Butte 115 kV bus and the new 230 kV bus were dispatched as an energy resource. The baseline results assumed the flow on the Lamar DC Tie was set at 200 MW East-West and West-East.

11. Results

11.1. ERZ-5 via Boone – Walsenburg 230 kV line

¹² “CSU” means Colorado Springs Utilities; “WAPA” means Western Area Power Administration and “Tri-State” means Tri-State Generation and Transmission Association, Inc.

The 2027HS study results indicated the BHCE transmission system could accommodate a maximum of 219 MW injection from ERZ-5 via the Rattlesnake-Reader 115 kV line, due to the thermal limit of the transmission line. This is a total amount rather than an incremental amount. That assumes the removal of terminal limitations on the Reader-Pueblo 115 kV line and the rebuilding of the Desert Cove-Fountain Valley-Midway 115 kV line. The 27HS case also indicated that a new Rattlesnake Butte 230 kV bus intersecting the hypothetical Boone-Walsenburg 230 kV line could accommodate an additional 525 MW of generation.

The West Canon-Poncha 115 kV line loaded up to 98% of its thermal rating with an injection of ~745 MW total from ERZ-5 following the loss of West Canon-Poncha 230 kV line. The Lamar DC tie was flowing 200 MW E-W in this case.

11.2. Results Summary

The evaluated scenarios identified the maximum allowable resource injection from ERZ-5, as well as the transmission system elements that limited such injections. Upgrades to the limiting transmission system elements often resulted in an increased injection capability. It is prudent to evaluate any identified upgrades in the context of resource needs and system capabilities.

The maximum allowable resource injection from ERZ-5 via the Reader-Rattlesnake Butte 115 kV line is 219 MW. By tapping a hypothetical 230 kV line between Boone and Walsenburg, the Rattlesnake Butte 230 kV and 115 kV buses could accommodate ~745 MW total. This reflects a significant increase from the findings of the 2013 analysis. That increase is primarily attributed to the transmission system upgrades that have been completed since 2013. Another likely contributing factor is differences in generation dispatch patterns in the general study area, which can have a significant impact on results.

Considering these findings, with Black Hills planned projects, as well as previously identified projects which fulfill the objective of the reliable delivery of beneficial energy resources to customer loads. These projects are described in more detail in Section 5.

12. Transmission System Expansion

The following transmission projects have been identified by Black Hills as fulfilling the objectives of the reliable delivery of beneficial energy resources to customer load.

12.1. Terminal Equipment Upgrades on Reader-Pueblo 115 kV line

The Reader-Pueblo 115 kV line is limited by terminal equipment (current transformers) to 160 MVA. By removing the current transformer limitations, the facility rating would increase to 182 MVA. This project is not expected to have any significant impact on noise or magnetic field levels at or near the Reader or Pueblo substations. This project will be designed to limit noise from the transmission facility to 50 d(B)A or less at the point of twenty-five feet from the edge of the property line or right-of-way and limit the magnetic field to 150 mG or less at the edge of the property line or right-of way. This project has not been formally proposed and no in-service date has been assigned.

12.2. Desert Cove-Fountain Valley-Midway 115 kV transmission line rebuild

The need to upgrade the capacity of this circuit has been identified in previous planning studies especially during periods of high South-North flows across the BHCE 115 kV system which result from generation in

ERZ-5 to serve load. The post-contingency loading on the Desert Cove - Fountain Valley - MidwayBR 115 kV line exceeds the 336 ACSR transmission line rating in all scenarios. Project Scope - rebuild the 14 mile Desert Cove - Fountain Valley - MidwayBR 115 kV line with at least 795 ACSR conductor and replace the limiting elements at Fountain Valley and MidwayBR.

12.3. Boone-Rattlesnake Butte-Walsenburg 230 kV line

This project is required to facilitate the total resource injection of 745 MW that was identified in this study. The new 69-mile, 230 kV line was previously identified as part of Tri-State’s 2014 transmission plan, but has since been removed from their planned project portfolio. This analysis was intended to capture the potential injection capability provided by the Boone-Walsenburg 230 kV line, recognizing the transmission system upgrades made by BHCE since this scenario was considered in the 2013 SB-100 study. Based on the limited need to require a significant amount of generation, as well as the considerable cost of this transmission line, the Boone-Walsenburg 230 kV line and its terminal components is not being proposed or pursued by Black Hills at this time.

13. Ordinary Course of Business

Black Hills believes that the projects detailed in Sections 5.1 and 5.2 are in the ordinary course of its business for several reasons. They are replacements for various components of Black Hills’ existing transmission and/or distribution facilities. They will enhance the local load serving function and will improve reliability of service to our Colorado customers. These projects are similar in purpose to previous Black Hills’ 115 kV projects the Commission has previously determined were in the “ordinary course of business.” These transmission projects will provide increased reliability and long-term load serving capability for Black Hills customers. These projects will be part of the Black Hills base transmission infrastructure that is critical to the interconnection and delivery of capacity and energy from Black Hills’ potential beneficial energy resources.

14. Conclusions

Black Hills utilized an open and transparent process in conducting its 2017 Colorado Senate Bill 07-100 study. Stakeholders were provided several opportunities for involvement and input into the study process and scope. Through this process, Black Hills believes it has fulfilled the requirements of Colorado Senate Bill 07-100, codified at Colo. Rev. Stat. § 40-2-126.

Designate Energy Resource Zones.

On November 24, 2008, Public Service Company of Colorado (“PSCo”) filed with the Commission an information report which identified its five ERZs within Colorado. Four of the ERZs identified by PSCo are located in close geographical proximity to the Black Hills system, specifically Zones 2, 3, 4 and 5. In the 2011 SB-100 study report Black Hills identified two ERZs (ERZ #1 & ERZ #2), both of which were located within the PSCo defined ERZ-5. In order to avoid confusion Black Hills has adopted the five PSCo defined ERZs within Colorado.

Develop plans for the construction or expansion of transmission facilities necessary to deliver electric power consistent with the timing of the development of beneficial energy resources located in or near such zones.

Black Hills identified the impacts of the various resource scenarios on the Black Hills transmission system and identified projects which ensure reliable delivery of beneficial energy resources from the designated ERZ-5 to customer loads.

Consider how transmission can be provided to encourage local ownership of renewable facilities, whether through renewable energy cooperatives as provided in Colo. Rev. Stat. § 7-56-210, or otherwise.

The identified new transmission projects will facilitate renewable resource development in ERZ-5 in excess of Black Hills' forecasted resource needs. The studied resource injections are in relatively close proximity to Black Hills customers and would be facilitated by a direct physical connection to the Black Hills electric system.

Submit proposed plans, designations, and applications for Certificates of Public Convenience and Necessity to the Commission for simultaneous review.

Black Hills believes that the 115 kV transmission projects it has identified to facilitate the reliable delivery of beneficial energy resources to customer load are “in the ordinary course of its business” and do not require CPCNs, pursuant to Colo. Rev. Stat. §§ 40-2-126(3) and 40-5-101. This excludes the hypothetical Boone-Walsenburg 230 kV line, which is not being proposed at this time. The resource injection amounts identified in this report are indicative of potential system performance under the evaluated scenarios but should not be construed to reflect firm system capability. In-depth analysis and coordination is required to establish a more comprehensive projection of potential system performance following implementation of the identified system upgrades.

Power Flow Analysis: Single Contingency (N-1) Outage List

Black Hills/Colorado Electric Utility Company, LP
2022 Rule 3627 Report – Appendix N – Black Hills Supporting Documents

Standard TPL-001-4 Transmission System Planning Performance Requirement (P1 Single Contingency)									
P1.1 GENERATOR		P1.2 TRANSMISSION CIRCUIT		P1.3 TRANSFORMER		P1.4 SHUNT DEVICE		P1.5 SINGLE POLE OF A DC LINE	
LABEL	DESCRIPTION	LABEL	DESCRIPTION	LABEL	DESCRIPTION	LABEL	DESCRIPTION	LABEL	DESCRIPTION
P1-1-1	PP MINE G1	P1-2-115-1	MIDWAY(WAPA)-DESERT COVE***	P1-3-115-1	AREQUA GULCH 115-69 T1	P1-4-115-1	AREQUA GULCH		NONE
P1-1-2	E CANON G1	P1-2-115-2	DESERT COVE-WEST STATION	P1-3-115-2	AREQUA GULCH 115-69 T2	P1-4-115-2	CANON CITY		
P1-1-3	PUB-DSLS G1	P1-2-115-3	MIDWAY(PSCO)-WEST STATION	P1-3-115-3	BACULITE MSA GEN3 U1 *	P1-4-115-3	PORTLAND		
P1-1-4	RF-DSLS G1	P1-2-115-4	MIDWAY(PSCO)-BACULITE MESA***	P1-3-115-4	BACULITE MSA GEN4 U1 *	P1-4-115-4	WEST CANON		
P1-1-5	APT-DSLS G1	P1-2-115-5	BACULITE MESA-WEST STATION-1	P1-3-115-5	BOONE 115-69 T1	P1-4-115-5	(TSGT) LAMAR CO		
P1-1-6	BAC-MSA GEN1 G1	P1-2-115-6	BACULITE MESA-WEST STATION-2	P1-3-115-6	CANON CITY 115-69 T1	P1-4-115-6	(TSGT) WILLOW CREEK		
P1-1-7	BAC-MSA GEN2 G1	P1-2-115-7	HYDE PARK-WEST STATION	P1-3-115-7	LAJUNTAW 115-69 T1	P1-4-115-7	(TSGT) LAJUNTA		
P1-1-8	BAC-MSA GEN3 G1 & ST1*	P1-2-115-8	HYDE PARK-PUEBLO	P1-3-115-8	LAJUNTAW 115-69 T2				
P1-1-9	BAC-MSA GEN3 G2 & ST1*	P1-2-115-9	PUEBLO-READER	P1-3-115-9	PORTLAND 115-69 T1				
P1-1-10	BAC-MSA GEN3 ST1	P1-2-115-10	PORTLAND-WEST STATION-1	P1-3-115-10	PORTLAND 115-69 T2				
P1-1-11	BAC-MSA GEN4 G1 & ST1*	P1-2-115-11	PORTLAND-WEST STATION-2	P1-3-115-11	READER 115-69 T1				
P1-1-12	BAC-MSA GEN4 G2 & ST1*	P1-2-115-12	WEST STATION-STEM BEACH***	P1-3-115-12	READER 115-69 T2				
P1-1-13	BAC-MSA GEN4 ST1	P1-2-115-13	BURNT MILL-WEST STATION	P1-3-115-13	WEST STATION 115-69 T1				
P1-1-14	BAC-MSA GEN5 G1	P1-2-115-14	BURNT MILL-GREENHORN	P1-3-115-14	WEST STATION 115-69 T2				
P1-1-15	BUSCH RANCH WPP-1	P1-2-115-15	GREENHORN-READER	P1-3-115-15	(TSGT) WILLOW CREEK T1				
P1-1-16	BUSCH RANCH WPP-2	P1-2-115-16	READER-AIRPORT MEMORIAL	P1-3-115-16	(TSGT) WILLOW CREEK T2				
P1-1-17	BUSCH RANCH WPP-3	P1-2-115-17	AIRPORT PARK-AIRPORT MEMORIAL	P1-3-115-17	(TSGT) LAJUNTA T2				
P1-1-18	COMANCHE C1	P1-2-115-18	AIRPORT PARK-BACULITE MESA	P1-3-115-18	(TSGT) VILAS T1				
P1-1-19	COMANCHE C2	P1-2-115-19	NYBERG-AIRPORT MEMORIAL						
P1-1-20	COMANCHE C3	P1-2-115-20	NYBERG-BACULITE MESA						
P1-1-21	COMANCHE PV	P1-2-115-21	NYBERG-BOONE***						
P1-1-22	LAMAR DC TIE	P1-2-115-22	NYBERG-BOONE						
P1-1-23	TWIN BUTTE W1	P1-2-115-23	BOONE-LAJUNTA(BHCE)						
P1-1-24	COLORADO GREEN E W1	P1-2-115-24	BOONE-LAJUNTA(TSGT)						
P1-1-25	COLORADO GREEN W W2	P1-2-115-25	COMANCHE-READER-1						
P1-1-26	FOUNTAIN VALLEY G1	P1-2-115-26	COMANCHE-READER-2						
P1-1-27	FOUNTAIN VALLEY G2	P1-2-115-27	PORTLAND-SKALA						
P1-1-28	FOUNTAIN VALLEY G3	P1-2-115-28	CANON CITY-SKALA						
P1-1-29	FOUNTAIN VALLEY G4	P1-2-115-29	CANON CITY-WEST CANON						
P1-1-30	FOUNTAIN VALLEY G5	P1-2-115-30	AREQUA GULCH-WEST CANON						
P1-1-31	FOUNTAIN VALLEY G6	P1-2-115-31	PONCHA-WEST CANON						
P1-1-32	JACKSON FULLER W1	P1-2-115-32	READER-RATTLESNAKE BUTTE						
P1-1-33	JACKSON FULLER W2	P1-2-115-33	(TSGT) LAJUNTAT-WILLOW CRK						
P1-1-34	SLVSOLAR S1	P1-2-115-34	(TSGT) LAMAR CO-WILLOW CRK						
P1-1-35	SLV-SOLAR S1	P1-2-115-35	(TSGT) LAMAR CO-VILAS						
P1-1-36	SOLAR GE S2	P1-2-115-36	MIDWAY(WAPA)-GEESEN(TSGT)**						
P1-1-37	SOLAR GE S3	P1-2-115-37	MIDWAY(WAPA)-NIXON(CSU)						
P1-1-38	NIXON ROAD C1								
		P1-2-230-1	(PSCO) LAMAR CO-BOONE	P1-3-230-1	(WAPA) MIDWAYBR T1				
		P1-2-230-2	(PSCO) BOONE-MIDWAY	P1-3-230-2	(PSCO) MIDWAYPS T1				
		P1-2-230-3	(PSCO) BOONE-COMANCHE	P1-3-230-3	(BHCE) WEST CANON T1				
		P1-2-230-4	(PSCO) COMANCHE-MIDWAYPS 1	P1-3-230-4	(PSCO) PONCHA T1				
		P1-2-230-5	(PSCO) COMANCHE-MIDWAYPS 2	P1-3-230-5	(TSGT) WALSENBURG T2				
		P1-2-230-6	COMANCHE(PSCO)-WALSENBURG (TSGT)	P1-3-230-6	(TSGT) WALSENBURG T3				
		P1-2-230-7	(TSGT) WALSENBURG-GLADSTONE	P1-3-230-7	(PSCO) COMANCHE T1				
		P1-2-230-8	PONCHA(WAPA)-SAN LUIS VALLEY (PSCO)	P1-3-230-8	(PSCO) COMANCHE T2				
		P1-2-230-9	(WAPA) PONCHABR-CURECANT	P1-3-230-9	(TSGT) GLADSTONE T1				
		P1-2-230-10	(WAPA) PONCHABR-WEST CANON	P1-3-230-10	(TSGT) GLADSTONE T2				
		P1-2-230-11	PONCHA(WAPA)-PONCHA(PSCO)	P1-3-230-11	(PSCO) BOONE T1				
		P1-2-230-12	(WAPA) WEST CANON-MIDWAYBR	P1-3-230-12	(TSGT) LAMAR T1				
		P1-2-230-13	MIDWAY(WAPA)-NIXON(CSU)	P1-3-230-13	(TSGT) LAMAR T2				
		P1-2-230-14	(PSCO) MIDWAY-JACKSON FULLER						
		P1-2-230-15	(PSCO) JACKSON FULLER-DANIELS PARK						
		P1-2-345-1	(PSCO) MIDWAYPS-WATERTON	P1-3-345-1	(PSCO) COMANCHE T3				
		P1-2-345-2	(PSCO) COMANCHE-DANIELS PARK 1	P1-3-345-2	(PSCO) COMANCHE T4				
		P1-2-345-3	(PSCO) COMANCHE-DANIELS PARK 2	P1-3-345-3	(PSCO) DANIELS PARK T2				
				P1-3-345-4	(PSCO) DANIELS PARK T3				
				P1-3-345-5	(PSCO) DANIELS PARK T4				

Black Hills Transmission System One Line Diagram

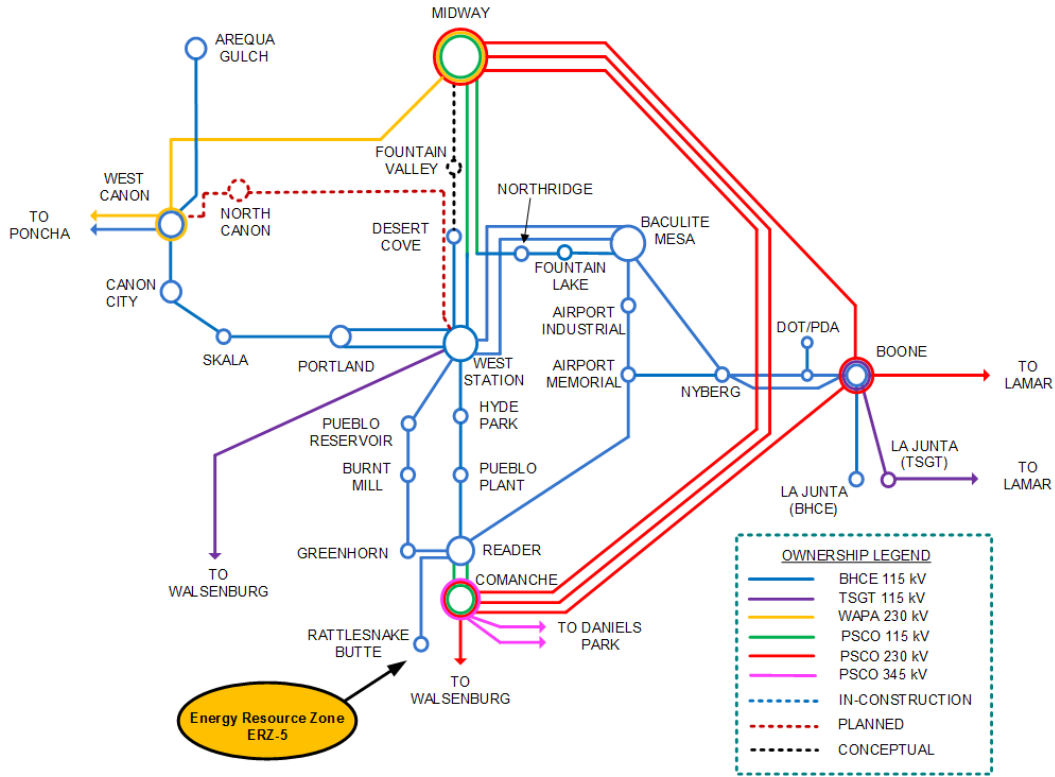

Black Hills Energy 2019 Senate Bill 07-100 Report



2019 SENATE BILL 07-100 REPORT:

**DESIGNATION OF ENERGY RESOURCE ZONES
AND
TRANSMISSION EXPANSION PLAN**

**BLACK HILLS/COLORADO ELECTRIC UTILITY COMPANY, L.P.,
D/B/A BLACK HILLS ENERGY**

PREPARED BY
BLACK HILLS CORPORATION
TRANSMISSION PLANNING

January 07, 2020

1. Introduction

14.1. 1.1. Colorado Senate Bill 07-100

On March 27, 2007, Colorado Senate Bill 07-100 (“SB-100”), codified at Colo. Rev. Stat. § 40-2-126(2), became effective. The purpose of the bill is to ensure that Colorado utilities “continually evaluate the adequacy of electric transmission facilities throughout the state” and “promptly and efficiently improve such infrastructure as required to meet the state’s existing and future energy needs.”

The bill specifically requires each Colorado electric utility that is subject to rate regulation by the Colorado Public Utilities Commission (“Commission”) to perform the following on or before October 31 of each odd-numbered year:

- (a) Designate Energy Resource Zones;

- (b) Develop plans for the construction or expansion of transmission facilities necessary to deliver electric power consistent with the timing of the development of beneficial energy resources located in or near such zones.

- (c) Consider how transmission can be provided to encourage local ownership of renewable facilities, whether through renewable energy cooperatives as provided in Colo. Rev. Stat. § 7-56-210, or otherwise; and

- (d) Submit proposed plans, designations, and applications for Certificates of Public Convenience and Necessity to the Commission for simultaneous review.

The requirement for a Certificate of Public Convenience and Necessity (“CPCN”) for a particular transmission project is governed by Colo. Rev. Stat. §§ 40-2-126 and 40-5-101 and by the process in Commission Rule 3206, 4 *Code of Colorado Regulations* 723-3.

14.2. 1.2. Stakeholder Participation

Black Hills/Colorado Electric Utility Company, L.P., d/b/a Black Hills Energy (“Black Hills”) encouraged all interested parties to participate in the 2019 SB-100 study process. An open stakeholder SB-100 Kick-off Meeting was held in conjunction with the Q1 Black Hills Colorado Transmission (“BHCT”) Transmission Coordination and Planning Committee (“TCPC”) on April 23, 2019 to inform stakeholders of the proposed study plan and to provide an opportunity for suggestions and feedback on the study process. The Kick-off Meeting had no external participants. A follow-up e-mail was sent on October 10, 2019, to invite stakeholders to respond with their input while updating them on the progress of the study work. Meeting notices and presentations were distributed via email and posted on the Black Hills OASIS page at <http://www.oatioasis.com/bhct/index.htm>.

2. Designation of Energy Resource Zones

14.3. 2.1. Zone Identification Assumptions

An Energy Resource Zone (“ERZ”), as defined in Colo. Rev. Stat. § 40-2-126(1), is “a geographic area in which transmission constraints hinder the delivery of electricity to Colorado consumers, the development of new electric generation facilities to serve Colorado consumers, or both.” SB-100

requires utilities to identify ERZs and to “develop plans for the construction and expansion of transmission facilities necessary to deliver electric power from resources in or near such zones.” Colo. Rev. Stat. § 40-2-126(2).

14.4. 2.2. Colorado-Wide ERZ Identification

On November 24, 2008, Public Service Company of Colorado (“PSCo”) filed with the Commission an information report which identified its five ERZs within Colorado. Black Hills has adopted the PSCo-defined ERZs within Colorado. These are shown in **Figure 1**. Four of the PSCo-defined ERZs are located in close geographical proximity to the Black Hills system, specifically Zones 2, 3, 4 and 5. Of these, Black Hills has studied Zone 5 in this report-based interconnection requests and identified projects.

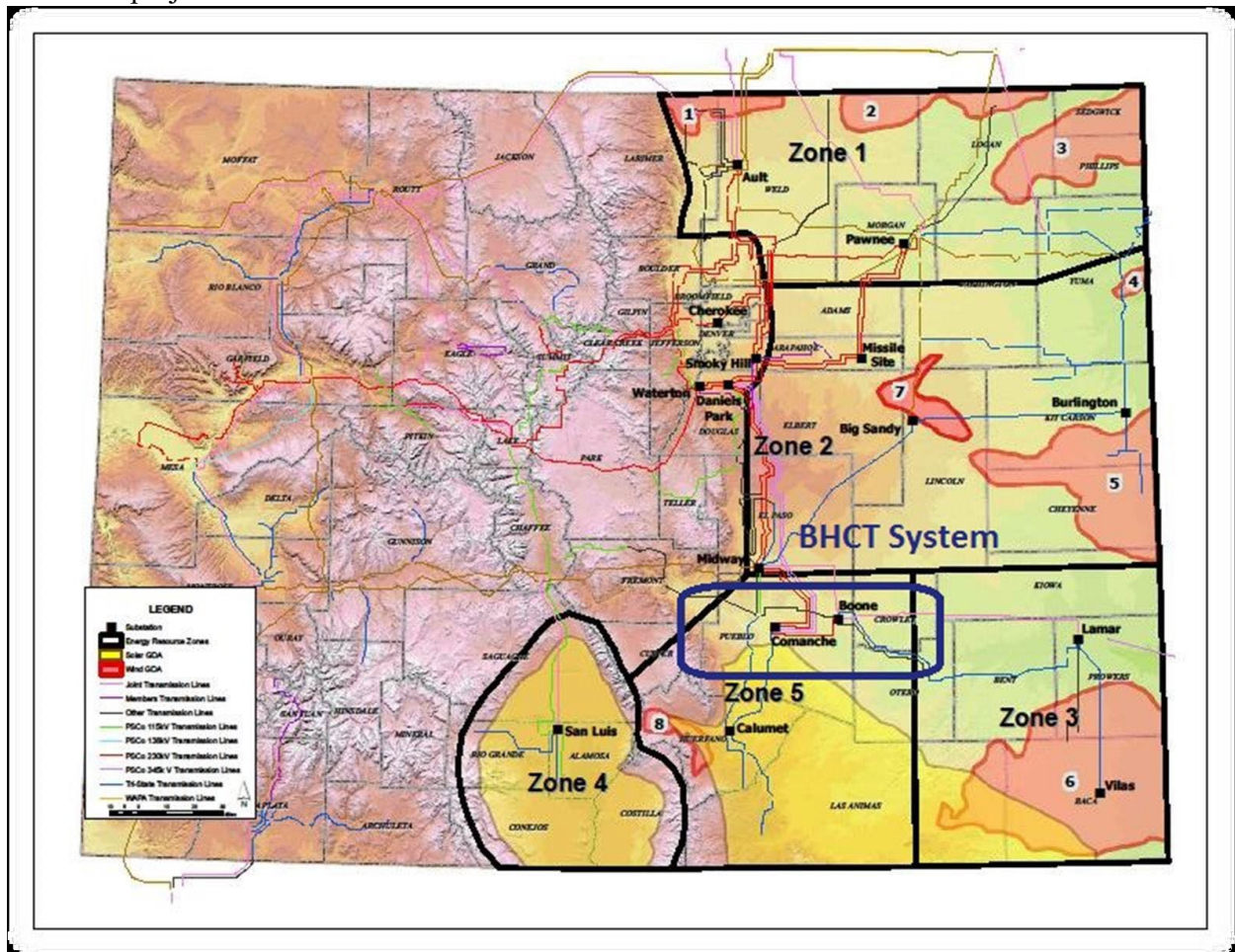

Figure 1: Black Hills Colorado Energy and PSCo Energy Resource Zones

3. Study Methodology

The information below details the study methodology by stating assumption made, reliability criteria, the study area and the study case development. The transmission system was evaluated under 2023 peak summer load levels to identify any significant adverse impact to the reliability and operating characteristics of the Western Electricity Coordinating Council (“WECC”) bulk transmission system and, more specifically, to the Black Hills and surrounding transmission systems. Steady state voltage and thermal analyses examined system performance without additional projects in order to establish a baseline for comparison. Performance was re-evaluated with resource injections modeled and

compared to the baseline performance to determine the impact of the injections on area transmission reliability.

14.5. 3.1. Assumptions

The analysis was performed with the following assumptions:

- All existing and planned facilities and the effects of control devices and protection systems were accurately represented in the system model.
- Projected firm transfers were represented per load and resource updates.
- Existing and planned reactive power resources were modeled to ensure adequate system performance.
- A list of the evaluated contingencies P1, P2 and P7 are included in Appendix A. Extreme contingencies were not simulated in this study.

The power flow analysis was performed with pre-contingency solution parameters that allowed adjustment of load tap-changing (“LTC”) transformers, static VAR devices including switched shunt capacitors and reactors, and DC taps. Post-contingency solution parameters allowed adjustment of DC taps and automatically switched shunt devices, as well as adjustment of manually switched shunt devices outside the study area. Area interchange control was disabled and generator VAR limits were applied immediately for all solutions. The solution method implemented was a fixed-slope decoupled Newton solution.

14.6. 3.2. Reliability Criteria

The criteria described in this section are consistent with the new NERC TPL Reliability Standard (TPL-001-4), the WECC System Performance Regional Criterion (TPL-001-WECC-CRT-3) and Colorado Coordinated Planning Group’s Voltage Coordination Guide.

14.6.1. 3.2.1. Steady State Voltage Criteria

Under system intact conditions P0, steady state bus voltages must remain between 0.95 and 1.05 per unit. Following Category P1 thru P7 contingencies, bus voltages must remain between 0.90 and 1.10 per unit. Pre-existing voltage violations outside the localized study area were ignored during the evaluation.

14.6.2. 3.2.2. Steady State Thermal Criteria

All line and transformer loading must be less than 100% of their established continuous rating for system normal conditions (NERC/WECC Category P0). All line and transformer loadings must be less than 100% of their established continuous or emergency rating under outage conditions (NERC/WECC Category P1-P7).

14.7. 3.3. Study Area

The Black Hills transmission system follows the Arkansas River Valley from the Royal Gorge west of Cañon City to La Junta. The major load centers on the system are at Cañon City to the west, Rocky Ford to the east, and Pueblo in the center. A one-line diagram of the Black Hills transmission system is included in Appendix B. Points of interconnection to the neighboring utilities are shown in Table 1.

Table 1: Black Hills Transmission System Interconnection Points

Interconnection Name	Interconnecting Utility
Midway (PSCo)	PSCo
Midway (WAPA)	WAPA, CSU, Tri-State
Boone	PSCo, Tri-State
Reader	PSCo

**Cañon West
West Station**

**WAPA, PSCO
Tri-State**

14.8. 3.4. Study Case Development

14.8.1. 3.4.1. 2023 Study Cases

The 2023 heavy summer time frame was chosen for this analysis for several reasons. The summer demand levels have historically been the most critical of the seasonal load patterns in the study area and the reduction in facility ratings due to the increased ambient temperatures during the summer months. The Colorado Coordinated Planning Group (CCPG) 2018 Compliance Study 2023HS case was used as the starting point for the 2023HS analysis.

Significant changes to the existing 2019 Black Hills transmission system to create the 2023 model included all projects listed in the most recent Colorado Rule 3206 filing (See Proceeding No. 19M-0005E). In all cases the Black Hills' loads were served by planned or existing Black Hills' generation.

14.8.2. 3.4.2. Resource Scenarios

Resource injection alternatives to each benchmark case were evaluated to identify impacts to the existing transmission system. Incremental generation injections from ERZ-5 at Baculite Mesa, Nyberg, South Fowler, and West Station were dispatched as energy resources. The increment values of injection were 50MW, 100MW, 150MW and 200MW at each pertinent location. To obtain more precise results, injection values of 75MW, 75MW and 175MW were analyzed for Nyberg, South Fowler and West Station respectively.

4. Results

14.9. 4.1. Baculite Mesa 115 kV Substation

The 2023HS study results indicated that the BHCE transmission system could accommodate a 200 MW injection at the Baculite Mesa 115 kV substation with no required upgrades, assuming all planned projects are in service.

14.10. 4.2. Nyberg 115 kV Substation

Additionally, the study results indicated that the BHCE transmission system could accommodate a 75 MW injection at the Nyberg 115 kV substation. Higher levels of injection into this substation caused overloads on XCEL's Boone 230/115 kV transformer during a P2 breaker failure contingency at Nyberg.

14.11. 4.3. South Fowler 115 kV Substation

The analysis also looked at injections at the planned South Fowler 115 kV substation. The results indicated that the BHCE transmission system could accommodate a 75 MW injection at this location. Higher levels of injection into this substation caused overloads on XCEL's Boone 230/115 kV transformer during a P2 breaker failure contingency at Nyberg. The breaker failure at Nyberg cuts off the only 115 kV paths to the western portion of BHCE's system. This forces the power through the Boone 230/115 kV transformer.

14.12. 4.4. West Station 115 kV Substation

The last injection point that was included in the analysis was the West Station 115 kV substation. The results indicated that the BHCE transmission system could accommodate a 175 MW injection at this location. Higher levels of injection caused overloads on the Fountain Valley – Midway 115 kV transmission line. These results included the planned rebuild rating for this line. Increasing this rating further would require substantial terminal equipment upgrades at the Midway substation.

5. Transmission System Expansion

The following transmission projects have been identified by Black Hills as fulfilling the objectives of the reliable delivery of beneficial energy resources to customer load. Below, 5.1 and 5.2 are planned projects, while 5.3 and 5.4 are not yet planned but are required to allow the injection to occur.

14.13. 5.1. Desert Cove – Fountain Valley – Midway 115 kV Transmission Line Rebuild

The need to upgrade the capacity of this circuit has been identified in previous planning studies. Especially during periods of high south to north flows across the BHCE 115 kV system which results from high generation in ERZ-5. As indicated in Section 4.4, this rebuild will be important to support potential generation injection at West Station. This project has a planned in service date of October 2020.

14.14. 5.2. Boone – South Fowler 115 kV line & South Fowler 115 kV Substation

The plan for this project is to rebuild the Boone – South Fowler Tap 69 kV line to 115 kV standards. A new 115 kV substation will be built at South Fowler Tap and the line will be energized at 115 kV. This project was identified to support the need for additional transformation in the Rocky Ford area and to provide a location for future voltage support equipment. As indicated in Section 4.3, the study results indicated that this location could support up to 50 MW of generation injection. This planned project will be required for the interconnection of any generation in this area. The planned in service date for this project is October 2021.

14.15. 5.3. Terminal Additions at Nyberg 115 kV and Baculite Mesa 115 kV

As indicated in Section 4, the Nyberg 115 kV substation and the Baculite Mesa 115 kV substation were studied as potential injection points, but there are currently no open terminals at either of these substations. Therefore, a terminal addition would be needed to accommodate any generation injection at these locations.

14.16. 5.4. Additional Transmission Feed into Rocky Ford Area

Black Hills has considered the reliability benefits of adding an additional transmission feed to the Rocky Ford area, but there is not enough load in the area to justify the cost of a new transmission line. As indicated in Sections 4.2 and 4.3, adding generation injection into Nyberg 115 kV or South Fowler 115 kV would likely require an additional transmission feed or additional transformation at Boone.

6. Ordinary Course of Business

Black Hills Corporation filed requests to identify if particular planned projects were deemed as ordinary course of business per the Public Utilities Commission. Released in 2019 under proceeding number 19M-0005E, the public utilities commission of the state of Colorado, under decision number C19-0638, determined that Boone – South Fowler line conversion rebuild and substation implementation did not require a CPCN and was therefore characterized as ordinary course of business. Previously, in 2018, under proceeding number 18M-0005E, the public utilities commission of the state of Colorado determined in C18-0843 that the Desert Cove – Fountain Valley – Midway line rebuild also did not require a CPCN and was therefore identified as ordinary course of business.

7. Conclusions

Black Hills utilized an open and transparent process in conducting its 2019 Colorado Senate Bill 07-100 study. Stakeholders were provided several opportunities for involvement and input into the study process and scope. Through this process, Black Hills believes it has fulfilled the requirements of Colorado Senate Bill 07-100, codified at Colo. Rev. Stat. § 40-2-126.

Designate Energy Resource Zones.

On November 24, 2008, Public Service Company of Colorado (“PSCo”) filed with the Commission an information report which identified its five ERZs within Colorado. Four of the ERZs identified by PSCo are located in close geographical proximity to the Black Hills system, specifically Zones 2, 3, 4 and 5. In the 2011 SB-100 study report Black Hills identified two ERZs (ERZ #1 & ERZ #2), both of which were located within the PSCo defined ERZ-5. In order to avoid confusion Black Hills has adopted the five PSCo defined ERZs within Colorado.

Develop plans for the construction or expansion of transmission facilities necessary to deliver electric power consistent with the timing of the development of beneficial energy resources located in or near such zones.

Black Hills identified the impacts of the various resource scenarios on the Black Hills transmission system and identified projects which ensure reliable delivery of beneficial energy resources from the designated ERZ-5 to customer loads.

Consider how transmission can be provided to encourage local ownership of renewable facilities, whether through renewable energy cooperatives as provided in Colo. Rev. Stat. § 7-56-210, or otherwise.

The identified new transmission projects will facilitate renewable resource development in ERZ-5 in excess of Black Hills’ forecasted resource needs. The studied resource injections are in relatively close proximity to Black Hills customers and would be facilitated by a direct physical connection to the Black Hills electric system.

Submit proposed plans, designations, and applications for Certificates of Public Convenience and Necessity to the Commission for simultaneous review.

**Black Hills/Colorado Electric Utility Company, LP
2022 Rule 3627 Report – Appendix N – Black Hills Supporting Documents**

**Appendix A:
Power Flow Analysis
Contingency (N-1, N-2) Outage List**

Standard TPL-001-4 Transmission System Planning Performance Requirement (P1 Single Contingency)							
P1.1 GENERATOR		P1.2 TRANSMISSION CIRCUIT		P1.3 TRANSFORMER		P1.4 SHUNT DEVICE	
LABEL	DESCRIPTION	LABEL	DESCRIPTION	LABEL	DESCRIPTION	LABEL	DESCRIPTION
P1-1-1	PUB-DSLS G1	P1-2-115-1	MIDWAY(WAPA)-DESERT COVE***	P1-3-115-1	AREQUA GULCH 115-69 T1	P1-4-115-1	AREQUA GULCH
P1-1-2	RF-DSLS G1	P1-2-115-2	DESERT COVE-WEST STATION	P1-3-115-2	AREQUA GULCH 115-69 T2	P1-4-115-2	CANON CITY
P1-1-3	APT-DSLS G1	P1-2-115-3	MIDWAY(PSCO)-WEST STATION	P1-3-115-3	BACULITE MSA GEN3 U1 *	P1-4-115-3	PORTLAND
P1-1-4	BAC-MSA GEN1 G1	P1-2-115-4	MIDWAY(PSCO)-OVERTON	P1-3-115-4	BACULITE MSA GEN4 U1 *	P1-4-115-4	WEST CANON
P1-1-5	BAC-MSA GEN2 G1	P1-2-115-5	FOUNTAIN LAKE-BACULITE MESA	P1-3-115-5	BOONE 115-69 T1	P1-4-115-5	(TSGT) LAMAR CO
P1-1-6	BAC-MSA GEN3 G1 & ST1*	P1-2-115-6	BACULITE MESA-WEST STATION-1	P1-3-115-6	CANON CITY 115-69 T1	P1-4-115-6	(TSGT) WILLOW CREEK
P1-1-7	BAC-MSA GEN3 G2 & ST1*	P1-2-115-7	BACULITE MESA-WEST STATION-2	P1-3-115-7	LAJUNTAW 115-69 T1	P1-4-115-7	(TSGT) LAJUNTA
P1-1-8	BAC-MSA GEN3 ST1	P1-2-115-8	HYDE PARK-WEST STATION				
P1-1-9	BAC-MSA GEN4 G1 & ST1*	P1-2-115-9	HYDE PARK-PUEBLO	P1-3-115-9	PORTLAND 115-69 T1		
P1-1-10	BAC-MSA GEN4 G2 & ST1*	P1-2-115-10	PUEBLO-READER	P1-3-115-10	PORTLAND 115-69 T2		
P1-1-11	BAC-MSA GEN4 ST1	P1-2-115-11	PORTLAND-WEST STATION-1	P1-3-115-11	READER 115-69 T1		
P1-1-12	BAC-MSA GEN5 G1	P1-2-115-12	PORTLAND-WEST STATION-2	P1-3-115-12	READER 115-69 T2		
P1-1-13	BUSCH RANCH WPP-1	P1-2-115-13	WEST STATION-STEM BEACH***	P1-3-115-13	WEST STATION 115-69 T1		
P1-1-14	BUSCH RANCH WPP-2	P1-2-115-14	BURNT MILL-PUEBLO RES.	P1-3-115-14	WEST STATION 115-69 T2		
P1-1-16	X645 S1 (PSCO SOLAR)	P1-2-115-15	PUEBLO RES.-WEST STATION	P1-3-115-15	(TSGT) WILLOW CREEK T1		
P1-1-17	COMANCHE C2	P1-2-115-16	BURNT MILL-GREENHORN	P1-3-115-16	(TSGT) WILLOW CREEK T2		
P1-1-18	COMANCHE C3	P1-2-115-17	GREENHORN-READER	P1-3-115-17	(TSGT) LAJUNTA T2		

Black Hills/Colorado Electric Utility Company, LP
2022 Rule 3627 Report – Appendix N – Black Hills Supporting Documents

P1-1-19	COMANCHE PV	P1-2-115-18	READER-AIRPORT MEMORIAL	P1-3-115-18	(TSGT) VILAS T1		
P1-1-20	LAMAR DC TIE	P1-2-115-19	AIRPORT PARK-AIRPORT MEMORIAL	P1-3-115-19	HOGBACK T1		
P1-1-21	TWIN BUTTE W1	P1-2-115-20	AIRPORT PARK-BACULITE MESA				
P1-1-22	COLORADO GREEN E W1	P1-2-115-21	NYBERG-AIRPORT MEMORIAL				
P1-1-23	COLORADO GREEN W W2	P1-2-115-22	NYBERG-BACULITE MESA				
P1-1-24	FOUNTAIN VALLEY G1	P1-2-115-23	NYBERG-BOONE***				
P1-1-25	FOUNTAIN VALLEY G2	P1-2-115-24	NYBERG-BOONE				
P1-1-26	FOUNTAIN VALLEY G3	P1-2-115-25	BOONE-LAJUNTA(BHCE)				
P1-1-27	FOUNTAIN VALLEY G4	P1-2-115-26	BOONE-LAJUNTA(TSGT)				
P1-1-28	FOUNTAIN VALLEY G5	P1-2-115-27	COMANCHE-READER-1				
P1-1-29	FOUNTAIN VALLEY G6	P1-2-115-28	COMANCHE-READER-2				
P1-1-30	JACKSON FULLER W1	P1-2-115-29	PORTLAND-SKALA				
P1-1-31	JACKSON FULLER W2						
P1-1-32	GR SANDH PV S1						
P1-1-33	SUNPOWER S1	P1-2-115-32	AREQUA GULCH-WEST CANON				
P1-1-34	SOLAR GE S1	P1-2-115-33	PONCHA-WEST CANON				
P1-1-35	COGENTIX PV S1	P1-2-115-34	READER-RATTLESNAKE BUTTE				
P1-1-36	NIXON ROAD 1	P1-2-115-35	(TSGT) LAJUNTAT-WILLOW CRK				
P1-1-37	PEAK VIEW WPP	P1-2-115-36	(TSGT) LAMAR CO-WILLOW CRK				
		P1-2-115-37	(TSGT) LAMAR CO-VILAS				
		P1-2-115-38	MIDWAY(WAPA)-GEESEN(TSGT)**				
		P1-2-115-39	MIDWAY(WAPA)-NIXON(CSU)				
		P1-2-115-40	WEST STATION-PUEBLO W				
		P1-2-115-41	PUEBLO W-N PENROSE				

Black Hills/Colorado Electric Utility Company, LP
2022 Rule 3627 Report – Appendix N – Black Hills Supporting Documents

	P1-2-115-42	N PENROSE-HOGBACK115			
	P1-2-115-43	W. CANON-HOGBACK115			
	P1-2-115-44	CANONCTY-HOGBACK115			
	P1-2-230-1	(PSCO) LAMAR CO-BOONE	P1-3-230-1	(WAPA) MIDWAYBR T1	
	P1-2-230-2	(PSCO) BOONE-MIDWAY	P1-3-230-2	(PSCO) MIDWAYPS T1	
	P1-2-230-3	(PSCO) BOONE-COMANCHE	P1-3-230-3	(BHCE) WEST CANON T1	
	P1-2-230-4	(PSCO) COMANCHE-MIDWAYPS 1	P1-3-230-4	(PSCO) PONCHA T1	
	P1-2-230-5	(PSCO) COMANCHE-MIDWAYPS 2	P1-3-230-5	(TSGT) WALSENBURG T2	
	P1-2-230-6	COMANCHE(PSCO)-WALSENBURG (TSGT)	P1-3-230-6	(TSGT) WALSENBURG T3	
	P1-2-230-7	(TSGT) WALSENBURG-GLADSTONE	P1-3-230-7	(PSCO) COMANCHE T1	
	P1-2-230-8	PONCHA(WAPA)-SAN LUIS VALLEY (PSCO)	P1-3-230-8	(PSCO) COMANCHE T2	
	P1-2-230-9	(WAPA) PONCHABR-CURECANT	P1-3-230-9	(TSGT) GLADSTONE T1	
	P1-2-230-10	(WAPA) PONCHABR-WEST CANON	P1-3-230-10	(TSGT) GLADSTONE T2	
	P1-2-230-11	PONCHA(WAPA)-PONCHA(PSCO)	P1-3-230-11	(PSCO) BOONE T1	
	P1-2-230-12	(WAPA) WEST CANON-MIDWAYBR	P1-3-230-12	(TSGT) LAMAR T1	
	P1-2-230-13	MIDWAY(WAPA)-NIXON(CSU)	P1-3-230-13	(TSGT) LAMAR T2	
	P1-2-230-14	(PSCO) MIDWAY-JACKSON FULLER			
	P1-2-230-15	(PSCO) JACKSON FULLER-DANIELS PARK			
	P1-2-230-16	(PSCO) COMANCHE - BADGER HILLS			
	P1-2-230-17	(PSCO) BADGER HILLS - MIDWAY			
	P1-2-345-1	(PSCO) MIDWAYPS-WATERTON	P1-3-345-1	(PSCO) COMANCHE T3	
	P1-2-345-2	(PSCO) COMANCHE-DANIELS PARK 1	P1-3-345-2	(PSCO) COMANCHE T4	

Black Hills/Colorado Electric Utility Company, LP
2022 Rule 3627 Report – Appendix N – Black Hills Supporting Documents

		P1-2-345-3	(PSCO) COMANCHE-DANIELS PARK 2	P1-3-345-3	(PSCO) DANIELS PARK T2		
				P1-3-345-4	(PSCO) DANIELS PARK T3		
				P1-3-345-5	(PSCO) DANIELS PARK T4		
				P1-3-345-6	(PSCO) MIDWAY T1		

Standard TPL-001-4 Transmission System Planning Performance Requirement (P2 Single Contingency)							
P2.1 LINE SECTION OPEN w/o FAULT		P2.2 BUS SECTION FAILURE		P2.3 BREAKER FAULT (NON BUS-TIE)		P2.4 BREAKER FAULT (BUS-TIE)	
LABEL	DESCRIPTION	LABEL	DESCRIPTION	LABEL	DESCRIPTION	LABEL	DESCRIPTION
P2-1-115-1	MIDWAYBR-FTN VALLEY	P2-2-115-1	AIRPORT INDUSTRIAL PARK	P2-3-115-1	WEST CANON (115-2)	P2-4-115-1	(WAPA&PSCO) MIDWAY (1162 CLOSED)
P2-1-115-2	FTN VALLEY-DESERT COVE	P2-2-115-2	AIRPORT MEMORIAL	P2-3-115-2	WEST CANON (115-3)		
P2-1-115-3	MIDWAYPS-NORTHRIDGE	P2-2-115-3	AREQUA GULCH	P2-3-115-3	WEST CANON (115-4)		
P2-1-115-4	NORTHRIDGE-FOUNTAIN LAKE	P2-2-115-4	BOONE	P2-3-115-4	WEST CANON (115-5)		
P2-1-115-5	NYBERG-DOT TAP	P2-2-115-5	BURNT MILL	P2-3-115-5	WEST CANON (115-6)		
P2-1-115-6	DOT TAP-BOONE	P2-2-115-6	PUEBLO RESERVOIR	P2-3-115-6	WEST CANON (115-7)		
P2-1-115-7	WEST STATION-PUEBLO TAP	P2-2-115-7	DESERT COVE	P2-3-115-7	WEST CANON (115-9)		
P2-1-115-8	PUEBLO TAP-STEM BEACH	P2-2-115-8	GREENHORN	P2-3-115-8	WEST CANON (115-10)		
		P2-2-115-9	HYDE PARK	P2-3-115-9	CANON CITY (115-1)		
		P2-2-115-10	LAJUNTAW	P2-3-115-10	CANON CITY (115-2)		
P2-1-115-11	PORTLAND-SKALA	P2-2-115-11	PUEBLO PLANT	P2-3-115-11	CANON CITY (115-3)		
P2-1-115-12	SKALA-CANON CITY	P2-2-115-12	SKALA	P2-3-115-12	CANON CITY (115-4)		

Black Hills/Colorado Electric Utility Company, LP
2022 Rule 3627 Report – Appendix N – Black Hills Supporting Documents

		P2-2-115-13	(WAPA) MIDWAYBR (1162 OPEN)	P2-3-115-13	CANON CITY (115-5)		
		P2-2-115-14	(PSCO) MIDWAYPS (1162 OPEN)	P2-3-115-14	CANON CITY (115-6)		
		P2-2-115-15	(TSGT) WALSENBURG (1362)	P2-3-115-15	WEST STATION (115-1)		
				P2-3-115-16	WEST STATION (115-3)		
				P2-3-115-17	WEST STATION (115-13)		
				P2-3-115-18	WEST STATION (115-14)		
		P2-2-230-1	(WAPA) MIDWAYBR	P2-3-115-19	WEST STATION (115-15)		
				P2-3-115-20	WEST STATION (115-16)		
				P2-3-115-21	WEST STATION (115-17)		
				P2-3-115-22	WEST STATION (115-18)		
				P2-3-115-23	WEST STATION (115-19)		
				P2-3-115-24	WEST STATION (115-20)		
				P2-3-115-25	WEST STATION (115-21)		
				P2-3-115-26	WEST STATION (115-22)		
				P2-3-115-27	WEST STATION (115-23)		
				P2-3-115-28	WEST STATION (115-24)		
				P2-3-115-29	WEST STATION (115-25)		
				P2-3-115-30	WEST STATION (115-26)		
				P2-3-115-31	WEST STATION (115-27)		
				P2-3-115-32	PORTLAND (115-C1)		
				P2-3-115-33	PORTLAND (115-2)		

Black Hills/Colorado Electric Utility Company, LP
2022 Rule 3627 Report – Appendix N – Black Hills Supporting Documents

				P2-3-115-34	PORTLAND (115-3)		
				P2-3-115-35	PORTLAND (115-4)		
				P2-3-115-36	PORTLAND (115-5)		
				P2-3-115-37	PORTLAND (115-6)		
				P2-3-115-38	PORTLAND (115-7)		
				P2-3-115-39	BACULITE MESA (115-1)		
				P2-3-115-40	BACULITE MESA (115-2)		
				P2-3-115-41	BACULITE MESA (115-3)		
				P2-3-115-42	BACULITE MESA (115-4)		
				P2-3-115-43	BACULITE MESA (115-5)		
				P2-3-115-44	BACULITE MESA (115-6)		
				P2-3-115-45	BACULITE MESA (115-7)		
				P2-3-115-46	BACULITE MESA (115-8)		
				P2-3-115-47	BACULITE MESA (115-9)		
				P2-3-115-48	BACULITE MESA (115-10)		
				P2-3-115-49	BACULITE MESA (115-11)		
				P2-3-115-50	BACULITE MESA (115-12)		
				P2-3-115-51	BACULITE MESA (115-13)		
				P2-3-115-52	BACULITE MESA (115-14)		
				P2-3-115-53	BACULITE MESA (115-15)		
				P2-3-115-54	NYBERG (115-1)		

Black Hills/Colorado Electric Utility Company, LP
2022 Rule 3627 Report – Appendix N – Black Hills Supporting Documents

				P2-3-115-55	NYBERG (115-2)		
				P2-3-115-56	NYBERG (115-3)		
				P2-3-115-57	NYBERG (115-4)		
				P2-3-115-58	READER (115-1)		
				P2-3-115-59	READER (115-2)		
				P2-3-115-60	READER (115-3)		
				P2-3-115-61	READER (115-4)		
				P2-3-115-62	READER (115-5)		
				P2-3-115-63	READER (115-6)		
				P2-3-115-64	READER (115-7)		
				P2-3-115-65	READER (115-8)		
				P2-3-115-66	READER (115-9)		
				P2-3-115-67	RATTLESNAKE BUTTE (115-1)		
				P2-3-115-68	RATTLESNAKE BUTTE (115-2)		
				P2-3-115-69	RATTLESNAKE BUTTE (115-3)		
				P2-3-115-70	RATTLESNAKE BUTTE (115-5)		
				P2-3-115-71	RATTLESNAKE BUTTE (115-6)		
				P2-3-230-1	(PSCO) MIDWAYPS (5120)		
				P2-3-230-2	(PSCO) MIDWAYPS (5126)		
				P2-3-230-3	(WAPA) WEST CANON (182)		

Black Hills/Colorado Electric Utility Company, LP
2022 Rule 3627 Report – Appendix N – Black Hills Supporting Documents

				P2-3-230-4	(WAPA) WEST CANON (282)		
				P2-3-230-5	(WAPA) WEST CANON (382)		
				P2-3-230-6	(WAPA) PONCHA (386)		
				P2-3-230-7	(WAPA) PONCHA (586)		
				P2-3-230-8	(WAPA) PONCHA (1186)		
				P2-3-230-9	(PSCO) BOONE (5335)		
				P2-3-230-10	(PSCO) BOONE (5336)		
				P2-3-230-11	(PSCO) BOONE (5337)		
				P2-3-230-12	(PSCO) BOONE (5415)		

**Black Hills/Colorado Electric Utility Company, LP
2022 Rule 3627 Report – Appendix N – Black Hills Supporting Documents**

Standard TPL-001-4 Transmission System Planning Performance Requirement (P7 Multiple Contingency - Common Structure)	
P7.1 TRANSMISSION CIRCUITS ON COMMON STRUCTURE	
LABEL	DESCRIPTION
P7-1-1	BACULITE MESA - WEST STATION #1 AND #2 115KV
P7-1-2	BOONE - DOT TAP - NYBERG & BOONE - NYBERG 115KV
P7-1-3	WEST STATION - MIDWAY (PSCO) & OVERTON - MIDWAY (PSCO) 115KV
P7-1-4	BOONE-LAJUNTA (TSGT & BHCE) 115KV
P7-1-5	(TSGT) LAMAR-VILAS & LAMAR-WILLOW CREEK 115 KV
P7-1-6	(TSGT) BOONE-LAMAR 230KV & BOONE-LAJUNTA 115KV
P7-1-7	(CSU) COTTONWOOD-STETSON & COTTONWOOD-FULLER 230kV
P7-1-8	(CSU) KELKER N-NIXON 230kV and KELKER S-FRTRANGE 230
P7-1-9	(CSU) FULLER-COTTONWOOD & FULLER-CLAREMNT 230KV
P7-1-10	(CSU) NIXON-CLAREMNT 1 & NIXON-CLAREMNT 2 230KV
P7-1-11	(PSCO) COMANCHE - MIDWAY CKTS #1 & #2 230KV
P7-1-12	(PSCO) DANIELPK - SANTAFE - ARAPAHOE & DANIELPK - MARCY - WATERTON 230 KV
P7-1-13	(PSCO) PAWNEE - BRICKCTR - QUINCY - SMOKY HILL & PAWNEE - DANIELPK 230KV
P7-1-14	(PSCO) MIDWAYPS - WATERTON 345KV & DANIELPK - FULLER 230KV
P7-1-15	(PSCO) MIDWAYPS - WATERTON 345KV & MIDWAYPS - FULLER 230KV
P7-1-16	(PSCO) DANIELPK - COMANCHE CKTS #1 & #2 345 KV
P7-1-17	(BHCE)Reader-Rattlesnake Butte 115KV & Reader-Greenhorn 115KV
P7-1-18	COMANCHE-MIDWAY 230 & COMANCHE - BADGER HILLS 230
P7-1-19	COMANCHE-MIDWAY 230 & BADGER HILLS 230 - MIDWAY 230
P7-1-20	WEST STATION - DESERT COVE & WEST STATION - PUEBLO WEST
P7-1-21	WEST CANO - AREQUA GULCH & WEST CANON - HOGBACK 115

**Appendix B:
Black Hills Transmission System One Line Diagram**

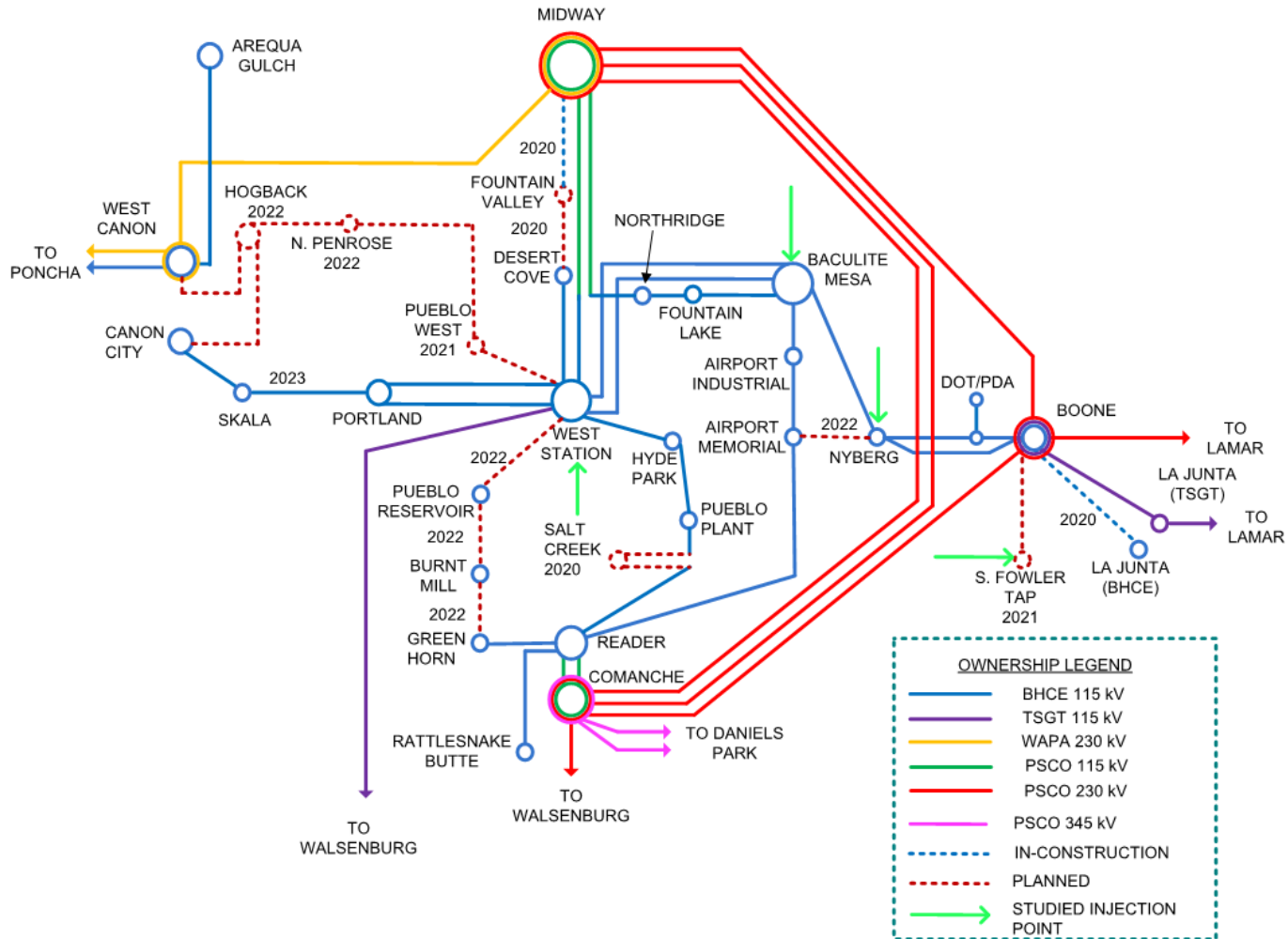

Black Hills Energy 2021 Senate Bill 07-100 Report



2021 SENATE BILL 07-100 REPORT:

**DESIGNATION OF ENERGY RESOURCE ZONES
AND
TRANSMISSION EXPANSION PLAN**

**BLACK HILLS/COLORADO ELECTRIC UTILITY COMPANY, L.P.,
D/B/A BLACK HILLS ENERGY**

PREPARED BY
BLACK HILLS CORPORATION
TRANSMISSION PLANNING

January 06, 2020

1. Introduction

14.17. 1.1. Colorado Senate Bill 07-100

On March 27, 2007, Colorado Senate Bill 07-100 (“SB-100”), codified at Colo. Rev. Stat. § 40-2-126(2), became effective. The purpose of the bill is to ensure that Colorado utilities “continually evaluate the adequacy of electric transmission facilities throughout the state” and “promptly and efficiently improve such infrastructure as required to meet the state’s existing and future energy needs.”

The bill specifically requires each Colorado electric utility that is subject to rate regulation by the Colorado Public Utilities Commission (“Commission”) to perform the following on or before October 31 of each odd-numbered year:

- (a) Designate Energy Resource Zones;
- (b) Develop plans for the construction or expansion of transmission facilities necessary to deliver electric power consistent with the timing of the development of beneficial energy resources located in or near such zones.
- (c) Consider how transmission can be provided to encourage local ownership of renewable facilities, whether through renewable energy cooperatives as provided in Colo. Rev. Stat. § 7-56-210, or otherwise; and
- (d) Submit proposed plans, designations, and applications for Certificates of Public Convenience and Necessity to the Commission for simultaneous review.

The requirement for a Certificate of Public Convenience and Necessity (“CPCN”) for a particular transmission project is governed by Colo. Rev. Stat. §§ 40-2-126 and 40-5-101 and by the process in Commission Rule 3206, 4 *Code of Colorado Regulations* 723-3.

14.18. 1.2. Stakeholder Participation

Black Hills/Colorado Electric Utility Company, L.P., d/b/a Black Hills Energy (“Black Hills”) encouraged all interested parties to participate in the 2021 SB-100 study process. An open stakeholder SB-100 Kick-off Meeting was held in conjunction with the Q1 Black Hills Colorado Transmission (“BHCT”) Transmission Coordination and Planning Committee (“TCPC”) on March 30, 2021 to inform stakeholders of the proposed study plan and to provide an opportunity for suggestions and feedback on the study process. Meeting notices and presentations were distributed via email and posted on the Black Hills OASIS page at <http://www.oatioasis.com/bhct/index.html>, as well as on a Colorado SB-100 webpage established on the Black Hills Corporation website at <https://www.blackhillsenergy.com/transmission-rates-and-planning/transmission-projects>.

2. Designation of Energy Resource Zones

14.19. 2.1. Zone Identification Assumptions

An Energy Resource Zone (“ERZ”), as defined in Colo. Rev. Stat. § 40-2-126(1), is “a geographic area in which transmission constraints hinder the delivery of electricity to Colorado consumers, the development of new electric generation facilities to serve Colorado consumers, or both.” SB-100 requires utilities to identify ERZs and to “develop plans for the construction and expansion of transmission facilities necessary to deliver electric power from resources in or near such zones.” Colo. Rev. Stat. § 40-2-126(2).

14.20. 2.2. Colorado-Wide ERZ Identification

On November 24, 2008, Public Service Company of Colorado (“PSCo”) filed with the Commission an information report which identified its five ERZs within Colorado. Black Hills has adopted the PSCo-defined ERZs within Colorado. These are shown in **Figure 1**. Four of the PSCo-defined ERZs are located in close geographical proximity to the Black Hills system, specifically Zones 2, 3, 4 and 5. Of these, Black Hills has studied Zone 5 in this report-based interconnection requests and identified projects.

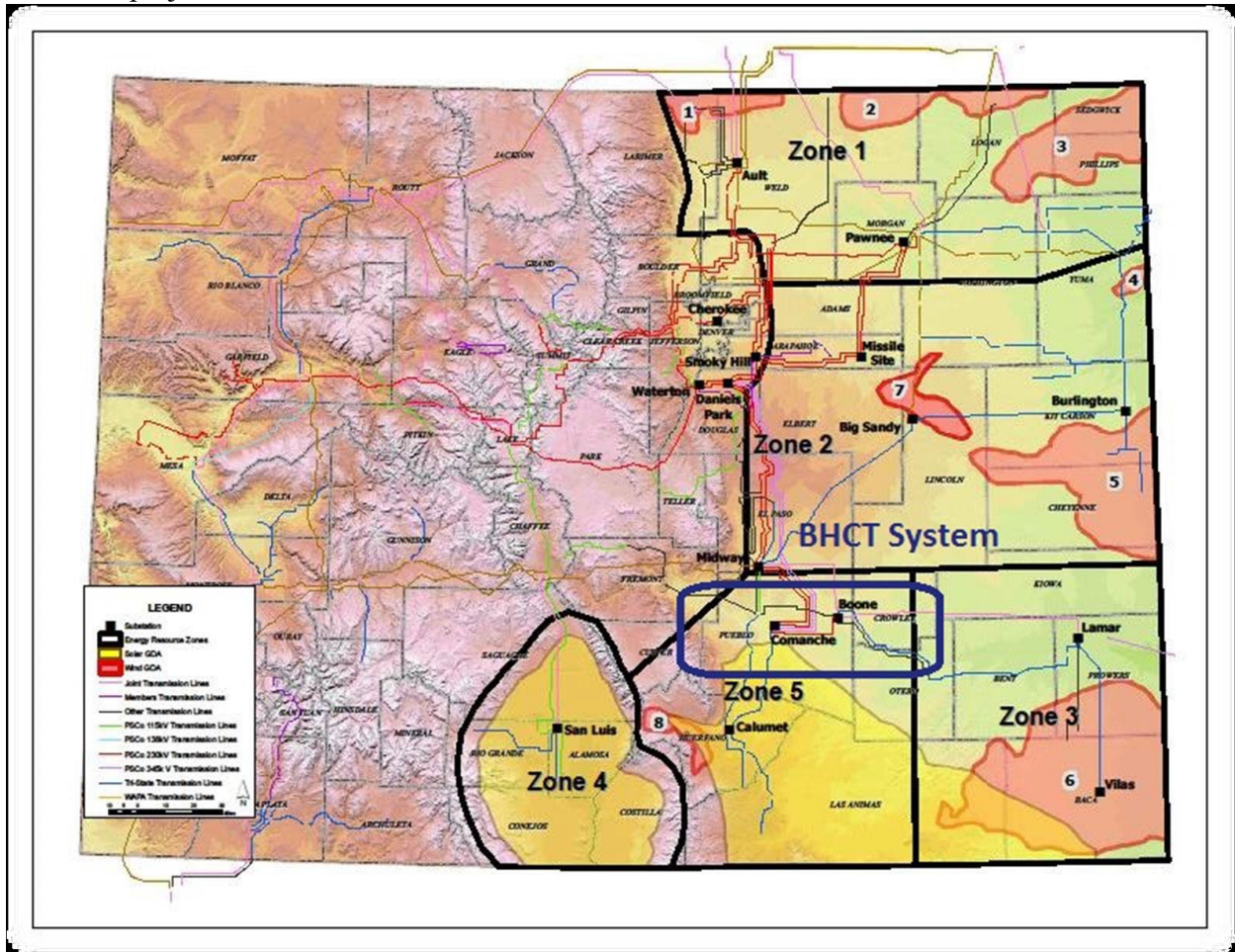

Figure 1: Black Hills Colorado Energy and PSCo Energy Resource Zones

3. Study Methodology

The SB-100 analysis was performed by running different contingencies using 50MW, 100MW, 150MW and 200MW at each pertinent location. The transmission system was evaluated under 2023 peak summer load levels to identify any significant adverse impact to the reliability and operating characteristics of the Western Electricity Coordinating Council (“WECC”) bulk transmission system and, more specifically, to the Black Hills and surrounding transmission systems. Steady state voltage and thermal analyses examined system performance without additional projects in order to establish a baseline for comparison. Performance was re-evaluated with resource injections modeled and compared to the baseline performance to determine the impact of the injections on area transmission reliability.

14.21. 3.1. Assumptions

The analysis was performed with the following assumptions:

- All existing and planned facilities and the effects of control devices and protection systems were accurately represented in the system model.
- Projected firm transfers were represented per load and resource updates.
- Existing and planned reactive power resources were modeled to ensure adequate system performance.
- A list of the evaluated contingencies P1, P2 and P7 are included in Appendix A. Extreme contingencies were not simulated in this study.

The power flow analysis was performed with pre-contingency solution parameters that allowed adjustment of load tap-changing (“LTC”) transformers, static VAR devices including switched shunt capacitors and reactors, and DC taps. Post-contingency solution parameters allowed adjustment of DC taps and automatically switched shunt devices, as well as adjustment of manually switched shunt devices outside the study area. Area interchange control was disabled and generator VAR limits were applied immediately for all solutions. The solution method implemented was a fixed-slope decoupled Newton solution.

14.22. 3.2. Reliability Criteria

The criteria described in this section are consistent with the new NERC TPL Reliability Standard (TPL-001-4), the WECC System Performance Regional Criterion (TPL-001-WECC-CRT-3) and Colorado Coordinated Planning Group’s Voltage Coordination Guide.

14.22.1. 3.2.1. Steady State Voltage Criteria

Under system intact conditions P0, steady state bus voltages must remain between 0.95 and 1.05 per unit. Following Category P1 thru P7 contingencies, bus voltages must remain between 0.90 and 1.10 per unit. Pre-existing voltage violations outside the localized study area were ignored during the evaluation.

14.22.2. 3.2.2. Steady State Thermal Criteria

All line and transformer loading must be less than 100% of their established continuous rating for system normal conditions (NERC/WECC Category P0). All line and transformer loadings must be less than 100% of their established continuous or emergency rating under outage conditions (NERC/WECC Category P1-P7).

14.23. 3.3. Study Area

The Black Hills transmission system follows the Arkansas River Valley from the Royal Gorge west of Cañon City to La Junta. The major load centers on the system are at Cañon City to the west, Rocky Ford to the east, and Pueblo in the center. A one-line diagram of the Black Hills transmission system is included in Appendix B. Points of interconnection to the neighboring utilities are shown in Table 1.

Table 1: Black Hills Transmission System Interconnection Points

Interconnection Name	Interconnecting Utility
Midway (PSCo)	PSCo
Midway (WAPA)	WAPA, CSU, Tri-State
Boone	PSCo, Tri-State
Reader	PSCo
Cañon West	WAPA, PSCO
West Station	Tri-State

14.24. 3.4. Study Case Development

14.24.1. 3.4.1. 2030 Study Cases

The 2030 heavy summer time frame was chosen for this analysis for several reasons. The summer demand levels have historically been the most critical of the seasonal load patterns in the study area and the reduction in facility ratings due to the increased ambient temperatures during the summer months. The Colorado Coordinated Planning Group (CCPG) 2020 Compliance Study 2030HS case was used as the starting point for the 2030HS analysis.

Significant changes to the existing 2021 Black Hills transmission system to create the 2030 model included all projects listed in the most recent Colorado Rule 3206 filing (See Proceeding No. 19M-0005E). In all cases the Black Hills' loads were served by planned or existing Black Hills' generation.

14.24.2. 3.4.2. Resource Scenarios

Resource injection alternatives to each benchmark case were evaluated to identify impacts to the existing transmission system. Incremental generation injections from ERZ-5 at Baculite Mesa, Boone, Hogback, Reader, and West Station were dispatched as energy resources.

4. Results

14.25. 4.1. Baculite Mesa 115 kV Substation

The 2030HS analysis indicated that the BHCE transmission system could accommodate a 150MW injection at the Baculite Mesa 115kV substation with no required upgrades, assuming all planned projects are in service. Any injection beyond that will cause overloads on the Baculite Mesa – Airport Memorial Park 115 kV line following the N-2 Contingency of the Baculite Mesa – West Station 115 kV #1 & #2 lines.

14.26.

14.27. 4.2. Nyberg 115 kV Substation

14.28. The 2030HS analysis indicated that the BHCE transmission system could accommodate a 160MW injection at the Boone 115kV substation. Higher levels of injection into this substation caused overloads on XCEL's Boone 230/115kV transformer during the N-2 contingency of the Boone – Nyberg 115 kV line & the Boone – Dot Tap – Nyberg 115 kV line.

14.29.

14.30. 4.3. South Fowler 115 kV Substation

14.31. The 2030HS analysis indicated that the BHCE transmission system could accommodate at 100MW injection at this location. Higher levels of injection into this substation caused overloads on the Hogback – Canon West 115 kV line. Injection limits into this area may vary greatly depending on local Canon City load, Turkey Creek PV output, and proposed transmission upgrades that may occur in the next 5-10 years. As injections increased beyond the 100 MW value there were overloads on the Canon West 230/115 kV transformer, Canon City – Hogback 115 kV line, Hogback 115/69 kV transformer, Canon City – Skala 115 kV line, and Portland – Skala 115 kV line.

14.32.

14.33. 4.4. Reader 115 kV Substation

The 2030HS analysis indicated that the Reader 115 kV substation could allow for 200 MW of injection. However, this analysis hinges on assumptions that generation retirements and additions in the Comanche area were captured and modelled correctly. Additionally, this injection limit can be impacted by the amount of generation that is entering the system from the Peakview and Rattlesnake wind farms south of

the Pueblo system. As generation in the area increases the risk of overloads in the area will increase following the loss of the Comanche – Daniels Park 345 kV double circuits. In this analysis the Tundra 345 kV generation was included and through flow through the Pueblo 115 kV system was at its peak during the Comanche – Daniels Park 345 kV & Daniels Park – Tundra 345 kV outage. This occurred as losing the 345 kV backbone from Comanche to Denver area load caused the generation to flow through the underlying 230 & 115 kV systems.

14.34. 4.4. West Station 115 kV Substation

The 2030HS analysis indicated that the BHCE transmission system could accommodate a 200 MW injection at this location. In previous study work high injections at the West Station substation caused issues on the Fountain Valley – Midway 115 kV line. A project to rebuild this line and address limiting substation equipment has increased the rating on the line when compared to previous years studies.

5. Transmission System Expansion

The following transmission projects have been identified by Black Hills as fulfilling the objectives of the reliable delivery of beneficial energy resources to customer load. Below, 5.1 and 5.2 are planned projects, while 5.3 and 5.4 are not yet planned but are required to allow the injection to occur.

14.35. 5.1. Desert Cove – Fountain Valley – Midway 115 kV Transmission Line Rebuild

The need to upgrade the capacity of this circuit has been identified in previous planning studies. Especially during periods of high south to north flows across the BHCE 115 kV system which results from high generation in ERZ-5. As indicated in Section 4.4, this rebuild will be important to support potential generation injection at West Station. This project has a planned in service date of October 2020.

14.36. 5.2. Boone – South Fowler 115 kV line & South Fowler 115 kV Substation

The plan for this project is to rebuild the Boone – South Fowler Tap 69 kV line to 115 kV standards. A new 115 kV substation will be built at South Fowler Tap and the line will be energized at 115 kV. This project was identified to support the need for additional transformation in the Rocky Ford area and to provide a location for future voltage support equipment. As indicated in Section 4.3, the study results indicated that this location could support up to 50 MW of generation injection. This planned project will be required for the interconnection of any generation in this area. The planned in service date for this project is October 2021.

14.37. 5.3. Terminal Additions at all studied substations

All of the studied injection substations currently have no open terminals to accommodate a potential interconnection. Therefore, a terminal addition would be required to accommodate any generation injection at the studied substations.

6. Ordinary Course of Business

Black Hills Corporation filed requests to identify if particular planned projects were deemed as ordinary course of business per the Public Utilities Commission. Released in 2019 under proceeding number 19M-0005E, the public utilities commission of the state of Colorado, under decision number C19-0638, determined that Boone – South Fowler line conversion rebuild and substation implementation did not require a CPCN and was therefore characterized as ordinary course of business. Previously, in 2018, under proceeding number 18M-0005E, the public utilities commission of the state of Colorado determined in C18-0843 that the Desert Cove – Fountain Valley – Midway line rebuild also did not require a CPCN and was therefore identified as ordinary course of business.

7. Conclusions

Black Hills utilized an open and transparent process in conducting its 2021 Colorado Senate Bill 07-100 study. Stakeholders were provided several opportunities for involvement and input into the study process and scope. Through this process, Black Hills believes it has fulfilled the requirements of Colorado Senate Bill 07-100, codified at Colo. Rev. Stat. § 40-2-126.

Designate Energy Resource Zones.

On November 24, 2008, Public Service Company of Colorado (“PSCo”) filed with the Commission an information report which identified its five ERZs within Colorado. Four of the ERZs identified by PSCo are located in close geographical proximity to the Black Hills system, specifically Zones 2, 3, 4 and 5. In the 2011 SB-100 study report Black Hills identified two ERZs (ERZ #1 & ERZ #2), both of which were located within the PSCo defined ERZ-5. In order to avoid confusion Black Hills has adopted the five PSCo defined ERZs within Colorado.

Develop plans for the construction or expansion of transmission facilities necessary to deliver electric power consistent with the timing of the development of beneficial energy resources located in or near such zones.

Black Hills identified the impacts of the various resource scenarios on the Black Hills transmission system and identified projects which ensure reliable delivery of beneficial energy resources from the designated ERZ-5 to customer loads.

Consider how transmission can be provided to encourage local ownership of renewable facilities, whether through renewable energy cooperatives as provided in Colo. Rev. Stat. § 7-56-210, or otherwise.

The identified new transmission projects will facilitate renewable resource development in ERZ-5 in excess of Black Hills’ forecasted resource needs. The studied resource injections are in relatively close proximity to Black Hills customers and would be facilitated by a direct physical connection to the Black Hills electric system.

Submit proposed plans, designations, and applications for Certificates of Public Convenience and Necessity to the Commission for simultaneous review.

Black Hills/Colorado Electric Utility Company, LP
2022 Rule 3627 Report – Appendix N – Black Hills Supporting Documents

Appendix A

Power Flow Analysis:

Contingency (N-1, N-2) Outage List

Standard TPL-001-4 Transmission System Planning Performance Requirement (P1 Single Contingency)							
P1.1 GENERATOR		P1.2 TRANSMISSION CIRCUIT		P1.3 TRANSFORMER		P1.4 SHUNT DEVICE	
LABEL	DESCRIPTION	LABEL	DESCRIPTION	LABEL	DESCRIPTION	LABEL	DESCRIPTION
P1-1-1	PUB-DSLS G1	P1-2-115-1	MIDWAY(WAPA)-DESERT COVE**	P1-3-115-1	AREQUA GULCH 115-69 T1	P1-4-115-1	AREQUA GULCH
P1-1-2	RF-DSLS G1	P1-2-115-2	DESERT COVE-WEST STATION	P1-3-115-2	AREQUA GULCH 115-69 T2	P1-4-115-2	CANON CITY
P1-1-3	APT-DSLS G1	P1-2-115-3	MIDWAY(PSCO)-WEST STATION	P1-3-115-3	BACULITE MSA GEN4 U1 *	P1-4-115-3	PORTLAND
P1-1-4	BAC-MSA GEN1 G1	P1-2-115-4	MIDWAY(PSCO)-FTN LAKE	P1-3-115-4	BACULITE MSA GEN5 U1 *	P1-4-115-4	WEST CANON (TSGT) LAMAR CO
P1-1-5	BAC-MSA GEN2 G1	P1-2-115-5	FOUNTAIN LAKE-BACULITE MESA	P1-3-115-5	BOONE 115-69 T1	P1-4-115-5	(TSGT) WILLOW CREEK
P1-1-6	BAC-MSA GEN4G1 & ST1*	P1-2-115-6	BACULITE MESA-WEST STATION-1	P1-3-115-6	CANON CITY 115-69 T1	P1-4-115-6	(TSGT) LAJUNTA
P1-1-7	BAC-MSA GEN4 G2 & ST1*	P1-2-115-7	BACULITE MESA-WEST STATION-2	P1-3-115-7	LAJUNTA 115-69 T1		
P1-1-8	BAC-MSA GEN4 ST1	P1-2-115-8	HYDE PARK-WEST STATION	P1-3-115-8	HOGBACK T1		
P1-1-9	BAC-MSA GEN5 G1 & ST1*	P1-2-115-9	HYDE PARK-PUEBLO	P1-3-115-9	PORTLAND 115-69 T1		
P1-1-10	BAC-MSA GEN5 G2 & ST1*	P1-2-115-10	PUEBLO-READER	P1-3-115-10	PORTLAND 115-69 T2		
P1-1-11	BAC-MSA GEN4 ST1	P1-2-115-11	PORTLAND-WEST STATION-1	P1-3-115-11	READER 115-69 T1		
P1-1-12	BAC-MSA GEN6 G1	P1-2-115-12	PORTLAND-WEST STATION-2	P1-3-115-12	READER 115-69 T2		
P1-1-13	BUSCH RANCH WPP-1	P1-2-115-13	WEST STATION-STEM BEACH***	P1-3-115-13	WEST STATION 115-69 T1		
P1-1-14	BUSCH RANCH WPP-2	P1-2-115-14	BURNT MILL-PUEBLO RES.	P1-3-115-14	WEST STATION 115-69 T2		
-	-	P1-2-115-15	PUEBLO RES.-WEST STATION	P1-3-115-15	(TSGT) WILLOW CREEK T1		
P1-1-16	COMANCHE C1	P1-2-115-16	BURNT MILL-GREENHORN	P1-3-115-16	(TSGT) WILLOW CREEK T2		
P1-1-17	COMANCHE C2	P1-2-115-17	GREENHORN-READER	P1-3-115-17	(TSGT) LAJUNTA T2		
P1-1-18	COMANCHE C3	P1-2-115-18	READER-AIRPORT MEMORIAL	P1-3-115-18	(TSGT) VILAS T1		

**Black Hills/Colorado Electric Utility Company, LP
2022 Rule 3627 Report – Appendix N – Black Hills Supporting Documents**

P1-1-19	COMANCHE PV	P1-2-115-19	AIRPORT PARK- AIRPORT MEMORIAL	P1-3-115-19	HOGBACK T1		
P1-1-20	LAMAR DC TIE	P1-2-115-20	AIRPORT PARK- BACULITE MESA				
P1-1-21	TWIN BUTTE W1	P1-2-115-21	NYBERG-AIRPORT MEMORIAL				
P1-1-22	COLORADO GREEN E W1	P1-2-115-22	NYBERG- BACULITE MESA				
P1-1-23	COLORADO GREEN W W2	P1-2-115-23	NYBERG-BOONE #1**				
P1-1-24	FOUNTAIN VALLEY G1	P1-2-115-24	NYBERG-BOONE #2				
P1-1-25	FOUNTAIN VALLEY G2	P1-2-115-25	BOONE- LAJUNTA(BHCE)				
P1-1-26	FOUNTAIN VALLEY G3	P1-2-115-26	BOONE- LAJUNTA(TSGT)				
P1-1-27	FOUNTAIN VALLEY G4	P1-2-115-27	COMANCHE- READER-1				
P1-1-28	FOUNTAIN VALLEY G5	P1-2-115-28	COMANCHE- READER-2				
P1-1-29	FOUNTAIN VALLEY G6	P1-2-115-29	PORTLAND- SKALA-CANON CITY				
P1-1-30	JACKSON FULLER W1						
P1-1-31	JACKSON FULLER W2	P1-2-115-31	CANON CITY- WEST CANON				
P1-1-32	SLV_SOLAR S1 SANDHILL	P1-2-115-32	AREQUA GULCH- WEST CANON				
P1-1-33	SLV_SOLAR S1 SUNPOWER	P1-2-115-33	PONCHA-WEST CANON				
P1-1-34	SLV_SOLAR S2 HOOPER	P1-2-115-34	READER- RATTLESNAKE BUTTE				
P1-1-35	SLV_SOLAR S3 COGENTRIX	P1-2-115-35	(TSGT) LAJUNTAT- WILLOW CRK				
P1-1-36	NIXON ROAD 1	P1-2-115-36	(TSGT) LAMAR_CO- WILLOW CRK				
P1-1-37	PEAK VIEW WPP	P1-2-115-37	(TSGT) LAMAR_CO- VILAS				
P1-1-38	TURKEY CREEK PV	P1-2-115-38	MIDWAY(WAPA)- GEESEN(TSGT)**				
		P1-2-115-39	MIDWAY(WAPA)- NIXON(CSU)				

Black Hills/Colorado Electric Utility Company, LP
2022 Rule 3627 Report – Appendix N – Black Hills Supporting Documents

		P1-2-115-40	W.STATION- PUEBLO W				
		P1-2-115-41	PUEBLO W- N PENROSE				
		P1-2-115-41A	PUEBLO WEST- TURKEY CREEK POI				
		P1-2-115-41B	TURKEY CREEK POI-NORTH PENROSE				
		P1-2-115-42	N PENROSE- HOGBACK115				
		P1-2-115-43	W.CANON- HOGBACK115				
		P1-2-115-44	CANONCTY- HOGBACK115				
		P1-2-230-1	(PSCO) LAMAR_CO- BOONE	P1-3-230-1	(WAPA) MIDWAYBR T1		
		P1-2-230-2	(PSCO) BOONE- MIDWAY	P1-3-230-2	(PSCO) MIDWAYPS T1		
		P1-2-230-3	(PSCO) BOONE- COMANCHE	P1-3-230-3	(BHCE) WEST CANON T1		
		P1-2-230-4	(PSCO) COMANCHE- MIDWAYPS 1	P1-3-230-4	(PSCO) PONCHA T1		
		P1-2-230-5	(PSCO) COMANCHE- MIDWAYPS 2	P1-3-230-5	(TSGT) WALSENBURG T2		
		P1-2-230-6	COMANCHE(PSCO))-WALSENBURG (TSGT)	P1-3-230-6	(TSGT) WALSENBURG T3		
		P1-2-230-7	(TSGT) WALSENBURG- GLADSTONE	P1-3-230-7	(PSCO) COMANCHE T1		
		P1-2-230-8	PONCHA(WAPA)- SAN LUIS VALLEY (PSCO)	P1-3-230-8	(PSCO) COMANCHE T2		
		P1-2-230-9	(WAPA) PONCHABR- CURECANT	P1-3-230-9	(TSGT) GLADSTONE T1		
		P1-2-230-10	(WAPA) PONCHABR-WEST CANON	P1-3-230-10	(TSGT) GLADSTONE T2		
		P1-2-230-11	PONCHA(WAPA)- PONCHA(PSCO)	P1-3-230-11	(PSCO) BOONE T1		

**Black Hills/Colorado Electric Utility Company, LP
2022 Rule 3627 Report – Appendix N – Black Hills Supporting Documents**

		P1-2-230-12	(WAPA) WEST CANON- MIDWAYBR	P1-3-230-12	(TSGT) LAMAR T1		
		P1-2-230-13	MIDWAY(WAPA)- NIXON(CSU)	P1-3-230-13	(TSGT) LAMAR T2		
		P1-2-230-14	(PSCO) MIDWAY- JACKSON FULLER				
		P1-2-230-15	(PSCO) JACKSON FULLER-DANIELS PARK				
		P1-2-230-16	(PSCO) COMMANCHE - BADGER HILLS				
		P1-2-230-17	(PSCO) BADGER HILLS - MIDWAY				
		P1-2-345-1	(PSCO) MIDWAYPS- WATERTON	P1-3-345-1	(PSCO) COMANCHE T3		
		P1-2-345-2	(PSCO) COMANCHE- DANIELS PARK 1	P1-3-345-2	(PSCO) COMANCHE T4		
		P1-2-345-3	(PSCO) COMANCHE- DANIELS PARK 2	P1-3-345-3	(PSCO) DANIELS PARK T3		
		P1-2-345-4	(PSCO) COMANCHE - BADGER HILLS	P1-3-345-4	(PSCO) DANIELS PARK T4		
		P1-2-345-5	(PSCO) BADGER HILLS - DANIELS PARK	P1-3-345-5	(PSCO) DANIELS PARK T5		
				P1-3-345-6	(PSCO) MIDWAY T1		
				P1-3-345-7	(PSCO) BADGER HILLS T1		

**Standard TPL-001-4 Transmission System Planning Performance Requirement
(P4 Multiple Contingency - *Fault plus stuck breaker*)**

Black Hills/Colorado Electric Utility Company, LP
2022 Rule 3627 Report – Appendix N – Black Hills Supporting Documents

P4.1 GENERATOR + STUCK BREAKER		P4.2 TRANSMISSION CIRCUIT + STUCK BREAKER		P4.3 TRANSFORMER + STUCK BREAKER		P4.4 SHUNT DEVICE + STUCK BREAKER	
LABEL	DESCRIPTION	LABEL	DESCRIPTION	LABEL	DESCRIPTION	LABEL	DESCRIPTION
P4-1-1	PUEBLO DSLS G1(69-25)	P4-2-115-1	BURNTMILL(115-1)-PUEBLO RESERVOIR	P4-3-115-1	AREQUA GULCH T1 (115-2)	P4-4-115-1	AREQUA GULCH (115-6)
P4-1-2	ROCKY FORD DSLS G1(14-8)	P4-2-115-2	BURNTMILL(115-2)-GREENHORN	P4-3-115-2	AREQUA GULCH T2 (115-3)	P4-4-115-2	PORTLAND (115-C1)
P4-1-3	AIRPORT INDUSTRIAL DSLS G1(115-5)	P4-2-115-3	GREENHORN(115-1)-BURNTMILL	P4-3-115-3	BACULITE MESA GEN1(115-2)		
P4-1-4	BACULITE MESA GEN1(115-2)	P4-2-115-4	GREENHORN(115-2)-READER	P4-3-115-4	BACULITE MESA GEN2(115-5)		
P4-1-5	BACULITE MESA GEN2(115-5)	P4-2-115-5	FOUNTAIN LAKE(115-1)-MIDWAYPS	P4-3-115-5	BACULITE MESA GEN6(115-8)		
P4-1-6	BACULITE MESA GEN6(115-8)	P4-2-115-6	FOUNTAIN LAKE(115-2)-BACULITE MESA	P4-3-115-6	BACULITE MESA GEN4(115-11)		
P4-1-7	BACULITE MESA GEN4(115-11)	P4-2-115-7	FOUNTAIN LAKE(115-3)-BACULITE MESA	P4-3-115-7	BACULITE MESA GEN5(115-14)		
P4-1-8	BACULITE MESA GEN5(115-14)	P4-2-115-8	FOUNTAIN LAKE(115-4)-BACULITE MESA	P4-3-115-8	BOONE T1 (8132)		
P4-1-9	BUSCH RANCH WPP G1(35-1)	P4-2-115-9	NYBERG(115-1)-AIRPORT MEMORIAL	P4-3-115-9	CANON CITY T1 (115-5)		
P4-1-10	BUSCH RANCH WPP G2(35-1)	P4-2-115-10	NYBERG(115-2)-AIRPORT MEMORIAL	P4-3-115-10	CANON CITY T1 (115-6)		
P4-1-11	BUSCH RANCH WPP G3(35-1)	P4-2-115-11	NYBERG(115-3)-BACULITE MESA	P4-3-115-11	LAJUNTAW T1 (115-1)		

**Black Hills/Colorado Electric Utility Company, LP
2022 Rule 3627 Report – Appendix N – Black Hills Supporting Documents**

P4-1-12	COMANCHE C1	P4-2-115-12	NYBERG(115-5)- BOONE	P4-3-115-12	PORTLAND T1 (115-4)		
P4-1-13	COMANCHE C2 and COMANCHE 345-230KV T3	P4-2-115-13	AIRPORT INDUSTRIAL(115 -1)-BACULITE MESA	P4-3-115-13	PORTLAND T1 (115-5)		
P4-1-14	COMANCHE C3	P4-2-115-14	AIRPORT INDUSTRIAL(115 -2)-AIRPORT MEMORIAL	P4-3-115-13	A PORTLAND T1 (115-5)		
P4-1-15	COMANCHE_ PV S1	P4-2-115-15	BACULITE MESA(115-2)- NYBERG	P4-3-115-15	PORTLAND T2 (115-4)		
P4-1-16	LAMAR DC TIE	P4-2-115-16	BACULITE MESA(115-5)- AIRPORT INDUSTRIAL	P4-3-115-16	READER T1 (115-1)		
P4-1-17	TWIN BUTTE W1	P4-2-115-17	BACULITE MESA(115-8)- W.STATION #2	P4-3-115-17	READER T1 (115-4)		
P4-1-18	COLORADO GREEN W1	P4-2-115-18	BACULITE MESA(115-11)- W.STATION #1	P4-3-115-18	READER T1 (115-7)		
P4-1-19	COLORADO GREEN W2	P4-2-115-19	BACULITE MESA(115-14)- FOUNTAIN LAKE	P4-3-115-19	READER T2 (115-3)		
P4-1-20	FOUNTAIN VALLEY G1 and FOUNTAIN VALLEY 230KV BUS	P4-2-115-20	BOONE(8134)- LAJUNTAT	P4-3-115-20	READER T2 (115-6)		
P4-1-21	FOUNTAIN VALLEY G2	P4-2-115-21	BOONE(9637)- DOT-NYBERG	P4-3-115-21	READER T2 (115-9)		

**Black Hills/Colorado Electric Utility Company, LP
2022 Rule 3627 Report – Appendix N – Black Hills Supporting Documents**

P4-1-22	FOUNTAIN VALLEY G3	P4-2-115-22	BOONE(115-1)-NYBERG	P4-3-115-22	W.STATION(15-1)		
P4-1-23	FOUNTAIN VALLEY G4	P4-2-115-23	CANON CITY(115-2)-SKALA	P4-3-115-23	W.STATION(15-13)		
P4-1-24	FOUNTAIN VALLEY G5	P4-2-115-24	CANON CITY(115-3)-SKALA	P4-3-115-24	W.STATION(15-18)		
P4-1-25	FOUNTAIN VALLEY G6	P4-2-115-25	CANON CITY(115-4)-WEST CANON	P4-3-115-25	W.STATION(15-19)		
P4-1-26	JACKSON FULLER W1	P4-2-115-26	HYDE PARK(115-1)-PUEBLO PLANT	P4-3-115-25	A W.STATION(15-19)		
P4-1-27	JACKSON FULLER W2	P4-2-115-27	HYDE PARK(115-2)-W.STATION	P4-3-115-26	W.STATION(15-24)		
P4-1-28	GR_SANDH_P V S1	P4-2-115-28	PORTLAND(115-2)-W.STATION #1	P4-3-115-26	A W.STATION(15-24)		
P4-1-29	SUNPOWER S1	P4-2-115-28	A PORTLAND(115-2)-G29 POI SEC #1	P4-3-115-27	W.STATION(15-25)		
P4-1-30	SOLAR_GE S1	P4-2-115-29	PORTLAND(115-3)-W.STATION #1	P4-3-115-28	W.STATION(15-3)		
P4-1-31	COGENTIX_P V S1	P4-2-115-29	A PORTLAND(115-3)-G29 POI SEC #1	P4-3-115-29	W.STATION(15-15)		
P4-1-32	NIXON ROAD C1 and NIXON-KELKER_N 230KV	P4-2-115-30	PORTLAND(115-5)-W.STATION #2	P4-3-115-30	W.STATION(15-16)		
P4-1-33	PEAK VIEW WPP G1	P4-2-115-30	A PORTLAND(115-	P4-3-115-31	W.STATION(15-21)		

Black Hills/Colorado Electric Utility Company, LP
2022 Rule 3627 Report – Appendix N – Black Hills Supporting Documents

			5)-G29 POI SEC #2				
		P4-2-115-31	PORTLAND(115-6)-G29 POI SEC #2	P4-3-115-32	W.STATION(115-22)		
		P4-2-115-31	PORTLAND(115-6)-W.STATION #2	P4-3-115-33	W.STATION(115-27)		
		P4-2-115-32	PORTLAND(115-7)-SKALA				
		P4-2-115-33	READER(115-1)-COMANCHE #2				
		P4-2-115-34	READER(115-2)-COMANCHE #2				
		P4-2-115-35	READER(115-3)-COMANCHE #1				
		P4-2-115-36	READER(115-4)-GREENHORN				
		P4-2-115-37	READER(115-5)-GREENHORN				
		P4-2-115-38	READER(115-6)-AIRPORT MEMORIAL				
		P4-2-115-39	READER(115-7)-RATTLESNAKE BUTTE				
		P4-2-115-40	READER(115-8)-RATTLESNAKE BUTTE				
		P4-2-115-41	READER(115-9)-PUEBLO PLANT				
		P4-2-115-42	DESERT COVE(115-1)-MIDWAYWBR				
		P4-2-115-43	DESERT COVE(115-2)-W.STATION				

Black Hills/Colorado Electric Utility Company, LP
2022 Rule 3627 Report – Appendix N – Black Hills Supporting Documents

		P4-2-115-44	W.STATION(115-13)-PUEBLO RES				
		P4-2-115-45	W.STATION(115-14)-HYDE PARK				
		P4-2-115-46	W.STATION(115-15)-HYDE PARK				
		P4-2-115-47	W.STATION(115-16)-MIDWAY				
		P4-2-115-48	W.STATION(115-17)-STEM BEACH				
		P4-2-115-49	W.STATION(115-18)-STEM BEACH				
		P4-2-115-50	W.STATION(115-19)- PORTLAND#2				
		P4-2-115-50	A W.STATION(115-19)-G29 POI SEC #2				
		P4-2-115-51	W.STATION(115-20)-BACULITE MESA#2				
		P4-2-115-51	A W.STATION(115-20)-BACULITE MESA#2				
		P4-2-115-52	W.STATION(115-21)-BACULITE MESA#2				
		P4-2-115-53	W.STATION(115-22)-BACULITE MESA#1				
		P4-2-115-54	W.STATION(115-23)- PORTLAND#1				

**Black Hills/Colorado Electric Utility Company, LP
2022 Rule 3627 Report – Appendix N – Black Hills Supporting Documents**

		P4-2-115-54	A W.STATION(115-23)-G29 POI SEC #1				
		P4-2-115-55	W.STATION(115-24)- PORTLAND#1				
		P4-2-115-55	A W.STATION(115-24)-G29 POI SEC #1				
		P4-2-115-56	W.STATION(115-25)-PUEBLO W.				
		P4-2-115-57	W.STATION(115-26)-DESERT COVE				
		P4-2-115-58	W.STATION(115-27)-DESERT COVE				
		P4-2-115-59	AIRPORT MEMORIAL(115-1)-AIRPORT INDUSTRIAL				
		P4-2-115-60	AIRPORT MEMORIAL(115-2)-READER				
		P4-2-115-61	WEST CANON(115-3)- SMELTER				
		P4-2-115-62	WEST CANON(115-6)- CANON CITY				
		P4-2-115-63	RATTLESNAKE BUTTE(115-1)- READER				

**Black Hills/Colorado Electric Utility Company, LP
2022 Rule 3627 Report – Appendix N – Black Hills Supporting Documents**

		P4-2-115-64	RATTLESNAKE BUTTE(115-2)-PEAKVIEW				
		P4-2-115-65	RATTLESNAKE BUTTE(115-4)-PEAKVIEW				
		P4-2-115-66	RATTLESNAKE BUTTE(115-6)-READER				
		P4-2-115-67	PUEBLO RESERVOIR(115-1)-W.STATION				
		P4-2-115-68	PUEBLO RESERVOIR(115-2)-BURNTMILL				
		P4-2-115-69	PUEBLO WEST(115-X)				
		P4-2-115-70	NORTH PENROSE(115-X)				

**Standard TPL-001-4 Transmission System Planning Performance Requirement (P7
Multiple Contingency - Common Structure)**

P7.1 TRANSMISSION CIRCUITS ON COMMON STRUCTURE

LABEL	DESCRIPTION
P7-1-1	BACULITE MESA - WEST STATION #1 AND #2 115KV
P7-1-2	BOONE - DOT TAP - NYBERG & BOONE - NYBERG 115KV
P7-1-3	WEST STATION - MIDWAY (PSCO) & OVERTON - MIDWAY (PSCO) 115KV
P7-1-4	BOONE-LAJUNTA (TSGT & BHCE) 115KV
P7-1-5	(TSGT) LAMAR-VILAS & LAMAR-WILLOW CREEK 115 KV

Black Hills/Colorado Electric Utility Company, LP
2022 Rule 3627 Report – Appendix N – Black Hills Supporting Documents

P7-1-6	(TSGT) BOONE-LAMAR 230KV & BOONE-LAJUNTAT 115KV
P7-1-7	(CSU) COTTONWOOD-STETSON & COTTONWOOD-FULLER 230kV
P7-1-8	(CSU) KELKER N-NIXON 230kV and KELKER S-FRTRANGE 230
P7-1-9	(CSU) FULLER-COTTONWOOD & FULLER-CLAREMNT 230KV
P7-1-10	(CSU) NIXON-CLAREMNT 1 & NIXON-CLAREMNT 2 230KV
P7-1-11	(PSCO) COMANCHE - MIDWAY CKTS #1 & #2 230KV
P7-1-12	(PSCO) DANIELPK - SANTA FE - ARAPAHOE & DANIELPK - MARCY - WATERTON 230 KV
P7-1-13	(PSCO) PAWNEE - BRICKCTR - QUINCY - SMOKY HILL & PAWNEE - DANIELPK 230KV
P7-1-14	(PSCO) MIDWAYPS - WATERTON 345KV & DANIELPK - FULLER 230KV
P7-1-15	(PSCO) MIDWAYPS - WATERTON 345KV & MIDWAYPS - FULLER 230KV
P7-1-16	DANIEL PARKK-COMANCHE 1&2 345KV
P7-1-17	READER-RATTLESNK 115KV & READER-GREENHORN 115KV
P7-1-18	COMANCHE-MIDWAY 230KV & COMANCHE-BADGER HILLS 230KV
P7-1-19	COMANCHE-MIDWAY 230KV & BADGER HILLS-MIDWAY 230KV
P7-1-20	COMANCHE-BADGER 345KV & COMANCHE-DANIELPK 345KV
P7-1-21	BADGER-DANIELPK 345KV & COMANCHE-DANIELPK 345KV
P7-1-22	WESTSTN-DESRTC OV 115KV & WESTSTN-PUEBLOWEST 115KV
P7-1-23	WESTCANON-AREQGLTCH 115KV & WESTCANON-HOGBACK 115KV

Appendix B
Black Hills Transmission System One Line Diagram:

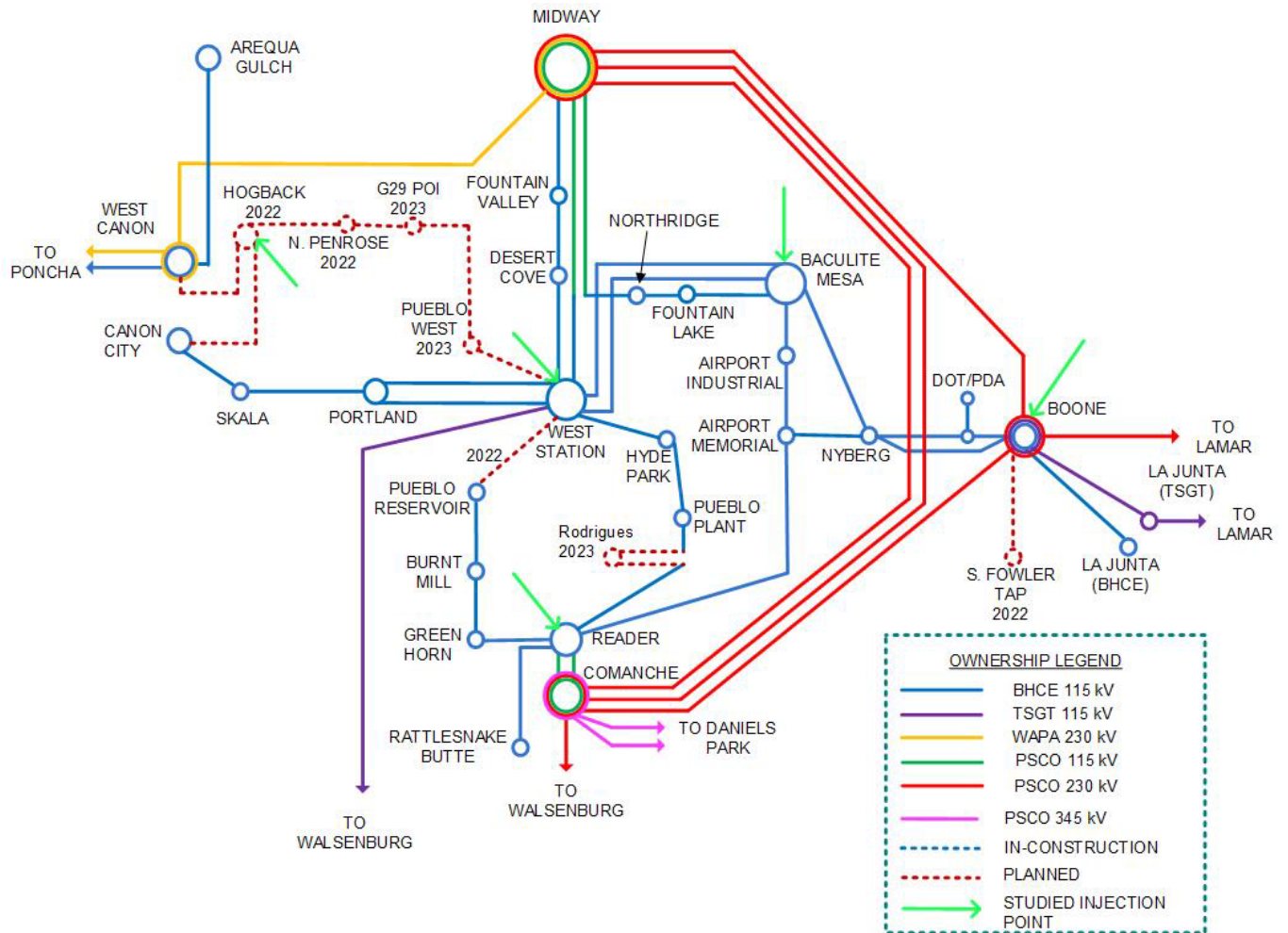

Black Hills Colorado Electric Generator Interconnection Queue

Black Hills/Colorado Electric Utility Company, LP 2022 Rule 3627 Report – Appendix N – Black Hills Supporting Documents

Date 1/2/2024

Black Hills Colorado Electric - Large Generator Interconnection Queue

Interconnection Request Information					Facility Output (MW)		Facility Location		Point of Interconnection	Projected In-Service	Generator Information		Study Report Status			Notes
Queue Number	Queue Date	Status	Company Name	Requested Service	Summer	Winter	County	State			Generation Type	Fuel Type	Feasibility	System Impact	Facilities	
BHCT-G1	2/12/2009	Withdrawn	Black Hills Corp	NR/ER	240	240	Pueblo	CO	Reader 115 kV	10/1/2011	Combustion Turbine	Nat. Gas				Withdrawn by Customer
BHCT-G2	4/1/2009	Withdrawn	Black Hills Corp	NR/ER	120	120	Pueblo	CO	Reader 115 kV	10/1/2011	Combustion Turbine					Withdrawn by Customer
BHCT-G3	4/3/2009	Complete	Black Hills Corp	NR/ER	200	200	Pueblo	CO	Airport Tap 115 kV	10/1/2011	Combustion Turbine	Nat. Gas	Complete	Complete	Complete	LGIA executed
BHCT-G4	4/3/2009	Complete	Black Hills Corp	NR/ER	100	100	Pueblo	CO	Airport Tap 115 kV	10/1/2011	Combustion Turbine	Nat. Gas	Complete	Complete	Complete	LGIA executed
BHCT-G5	4/3/2009	Complete	Black Hills Corp	NR/ER	100	100	Pueblo	CO	Airport Tap 115 kV	10/1/2011	Combustion Turbine	Nat. Gas	Complete	Complete	Complete	LGIA executed
BHCT-G6	12/3/2010	Complete	Black Hills Corp	NR	40	40	Pueblo	CO	Baculite Mesa	6/6/2016	Combustion Turbine	Nat. Gas	NA	Complete	Complete	LGIA executed
BHCT-G7	12/27/2010	Queue Number assigned to an SGIP project														Withdrawn by Customer
BHCT-G8	1/4/2011	Complete	Black Hills Corp	ER	29	29	Huerfano	CO	Rattlesnake Butte 115kV	12/1/2015	Wind		NA	Complete	Complete	LGIA executed
BHCT-G9	2/21/2011	Queue Number assigned to an SGIP project														
BHCT-G10	9/7/2011	Complete	Black Hills Corp	NR	29	29	Huerfano	CO	Rattlesnake Butte 115kV	6/1/2020	Wind		NA	Complete	Complete	LGIA executed
BHCT-G11	6/26/2012	Complete	Black Hills Corp	NR	29	29	Huerfano	CO	Rattlesnake Butte 115kV	6/1/2020	Wind		NA	Complete	Complete	LGIA executed
BHCT-G12	2/28/2014	Withdrawn	Black Hills Corp	ER	60	60	Pueblo	CO	Nyberg Substation 115 kV	6/1/2016	Solar		NA	In Progress		Withdrawn
BHCT-G13	9/4/2014	Terminated		NR/ER	63	63	Pueblo	CO	Boone Substation 115 kV	12/1/2017	Solar		NA	Complete	Complete	Draft LGIA
BHCT-G14	9/19/2014	Withdrawn		NR/ER	120	120	Pueblo	CO	Reader-Pueblo Airport 115 kV	12/1/2016	Solar		NA			Withdrawn
BHCT-G15		Withdrawn		NR	35	35	Pueblo	CO	Nyberg Substation 115 kV	12/31/2016	Solar		NA			Withdrawn
BHCT-G16		Withdrawn		NR	20	20	Pueblo	CO	Boone 69 kV Bus	10/31/2016	Solar		NA			Withdrawn
BHCT-G17	1/8/2015	Withdrawn		NR	46.4	46.4	Pueblo	CO	Burnt Mill Substation	4/1/2016	Solar		NA			Withdrawn
BHCT-G18	1/20/2015	Complete		NR/ER	60	60	Huerfano	CO	Rattlesnake Butte 115kV	10/1/2016	Wind		Complete	Complete	Complete	LGIA Executed
BHCT-G19	4/1/2015	Active		NR	60	60	Pueblo	CO	Pueblo Airport Sub	11/1/2019	Solar		Complete	Complete	Complete	LGIA Draft
BHCT-G20	11/5/2015	Active	Black Hills Corp	NR	60	60	Pueblo	CO	Pueblo Airport Sub	1/1/2022	Solar		Complete	Complete	Complete	LGIA Draft
BHCT-G21	1/27/2017	Active		NR/ER	80	80	Pueblo	CO	Boone Substation	12/31/2018	Solar		Complete	Complete	Complete	LGIA Draft
BHCT-G22	5/11/2017	Withdrawn		NR/ER	60	60	Pueblo	CO	Reader-Pueblo Airport 115kV	6/1/2020	Solar					Withdrawn
BHCT-G23	6/1/2017	Withdrawn		NR/ER	50	50	Pueblo	CO	Midway-Westerton line	11/30/2019	Solar					Withdrawn
BHCT-G24	9/14/2018	Complete	Black Hills Electric Generation LLC	NR	132	132	Huerfano	CO	Rattlesnake Butte 115kV Sub	6/1/2020	Wind		NA	Complete		LGIA executed
BHCT-G25		Withdrawn		NR	95	95	Pueblo	CO	La Junta 115kV Sub	12/1/2020	Solar					Withdrawn
BHCT-G26	11/20/2019	Withdrawn		NR/ER	125	125	Pueblo	CO	Reader-Pueblo Plant 115 kV	12/31/2022	Solar		Complete			Withdrawn
BHCT-G27	12/6/2019	Withdrawn		NR	100	100	Pueblo	CO	Reader - Rattlesnake Butte 115 kV	11/1/2022	Solar		NA	Complete	Complete	LGIA Draft
BHCT-G28	2/27/2020	Active		NR/ER	75	75	Pueblo	CO	Nyberg 115kV Substation	12/31/2023	Solar		Complete	Complete	Complete	Draft LGIA
BHCT-G29	8/28/2020	Complete		NR	200	200	Pueblo	CO	Pueblo West - North Penrose 115kV	3/31/2023	Solar		NA	Complete	Complete	LGIA Executed
BHCT-G30	8/23/2021	Withdrawn		NR/ER	80	80	Pueblo	CO	West Station 115kV	9/15/2024	Solar		Complete			Withdrawn
BHCT-G31	9/20/2021	Withdrawn		NR/ER	31.95	31.95	Pueblo	CO	Portland 115kV Sub	12/31/2023	Solar		In Progress			Withdrawn
BHCT-G32	4/22/2022	Active		NR/ER	200	200	Pueblo	CO	Burnt Mill Substation	4/1/2025	Solar/Battery		NA	Complete	Complete	
BHCT-G33	6/16/2022	Active		NR/ER	199	199	Pueblo	CO	Boone 115 kV	12/31/2025	Solar		Complete	Complete	Complete	
BHCT-G34	7/14/2022	Active		ER	24	24	Fremont	CO	Skala Substation	12/31/2025	Solar		NA	Complete	Complete	
BHCT-G35	8/9/2022	Active		NR/ER	150	150	Pueblo	CO	Reader - Rattlesnake 115kV Line	12/31/2026	Solar/Battery		NA	Complete	Complete	
BHCT-G36	8/9/2022	Active		NR/ER	80	80	Pueblo	CO	Boone Substation	12/1/2026	Solar/Battery		NA	Complete	Complete	
BHCT-G37	8/9/2022	Active		NR/ER	50	50	Pueblo	CO	West Station 115kV Substation	12/1/2026	Storage		NA	Complete	Complete	
BHCT-G38	8/18/2022	Active		NR/ER	150	150	Pueblo	CO	Baculite Mesa Substation	12/1/2025	Solar/Battery		Complete	Complete	Complete	
BHCT-G39	9/23/2022	Withdrawn		NR/ER	40	40	Otero	CO	LaJunta 115 kV Substation	12/31/2025	Solar/Battery		NA			Withdrawn
BHCT-G40	11/7/2022	Withdrawn		NR/ER	200	200	Pueblo	CO	Baculite Mesa 115 kV Substation	6/1/2025	Solar		Complete			Withdrawn
BHCT-G41	4/7/2023	Withdrawn		NR/ER	100	100	Pueblo	CO	Reader - Rattlesnake Butte 115 kV Line	12/31/2025	Wind		NA	Complete		Withdrawn
BHCT-G42	4/7/2023	Withdrawn		NR/ER	70	70	Pueblo	CO	Reader - Rattlesnake Butte 115 kV Line	12/31/2025	Wind		NA	Complete		Withdrawn
BHCT-G43	4/26/2023	Withdrawn		NR/ER	150	150	Otero	CO	South Fowler 115kV Substation	12/31/2026	Solar		Complete			Withdrawn
BHCT-G44	6/26/2023	Active		NR/ER	50	50	Otero	CO	South Fowler 115 kV Substation	6/1/2027	Solar/Battery		NA	Complete		
BHCT-G45	7/14/2023	Withdrawn		NR/ER	100	100	Pueblo	CO	Boone - LaJunta 115kV Line	12/30/2026	Solar/Battery		Complete			Withdrawn
BHCT-G46	11/13/2023	Active		NR/ER	200	200	Pueblo	CO	Airport Memorial - Reader 115 kV Line	12/31/2026	Solar/Battery		In Progress			
BHCT-G47	12/19/2023	Active		NR/ER	50	50	Fremont	CO	West Canon 115 kV Substation	1/1/2027	Battery					

Company Name: Only displayed after Interconnection Agreement has been executed, unless an Affiliate.
 Service Type: Not applicable to Large Generator Interconnection requests made prior to 01/20/2004, Small Generator Interconnection requests, or Qualifying Facility Interconnection requests.
 ER: Energy Resource Interconnection Service
 NR: Network Resource Interconnection Service
 NR with ER: Network Resource Interconnection Service requested, but also studied as Energy Resource. Customer will choose Service Type (ER or NR) prior to Facilities Study.